

# Homestyle Frontload Washers

Refer to Page 6 for Model Numbers

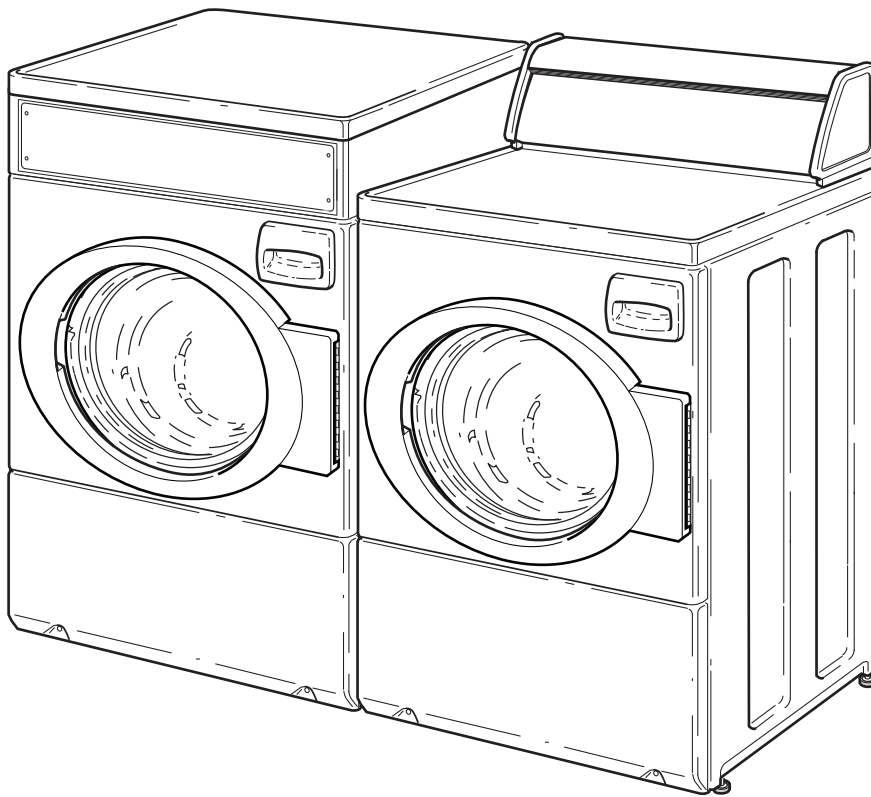

FLW1536C

— Troubleshooting —



# Table of Contents

<b>Section 1 – Safety Information .....</b>	<b>3</b>
Locating an Authorized Servicer .....	4
<b>Section 2 – Introduction .....</b>	<b>5</b>
Customer Service.....	5
Nameplate Location.....	5
Model Identification .....	6
Theory of Operation (Front Control Shown) .....	7
<b>Section 3 – Troubleshooting.....</b>	<b>9</b>
1. Motor Circuit.....	9
2. Troubleshooting Knocking Noise .....	9
3. No Spin Due to Out-of-Balance Switch Wiring Problem Starting Serial Nos. Beginning 0307.....	10
4. Troubleshooting LEDs on Washer Inverter Controls Starting Machine Serial No. 0911014603.....	11
5. No Spin (Washer).....	11
6. Troubleshooting Shock Absorbers.....	13
7. Error Code Listing .....	15
8. Washer Will Not Start – No LEDs/Lights Lit (No response to start switch).....	16
9. Washer Will Not Start – Door Open Error (Wash/Rinse LEDs Flashing – Door must be closed and attempting to lock).....	18
10. Washer Will Not Start – No Door Lock (Door LED Flashing).....	20
11. Motor Will Not Run (Door/Final Spin LEDs Flashing) .....	22
12. Washer Will Not Fill – No Communication Error (Wash/Door LEDs Flashing) .....	24
13. Washer Overflows.....	26
14. Pump Does Not Operate .....	28
15. Serial Communication Error (Final Spin/Rinse LEDs Flashing) .....	30
16. Washer Will Not Heat – Open/Shorted Temperature Sensor (Heating LED flashing at end of cycle) (Models equipped with heater) .....	32
17. Washer Will Not Heat (Models equipped with heater).....	34
<b>Section 4 – Adjustments .....</b>	<b>37</b>
18. Cabinet Leveling Legs .....	37
19. Loading Door .....	38
20. Door Catch .....	39
21. Motor Belt Tension .....	41
22. Shipping Braces .....	42

© Copyright 2011, Alliance Laundry Systems LLC

All rights reserved. No part of the contents of this book may be reproduced or transmitted in any form or by any means without the expressed written consent of the publisher.



# Section 1

## Safety Information

Throughout this manual and on machine decals, you will find precautionary statements (“CAUTION,” “WARNING” and “DANGER”) followed by specific instructions. These precautions are intended for the personal safety of the operator, user, servicer, and those maintaining the machine.

### **▲ DANGER**

Danger indicates an imminently hazardous situation that, if not avoided, will cause severe personal injury or death.

### **WARNING**

Warning indicates a hazardous situation that, if not avoided, could cause severe personal injury or death.

### **CAUTION**

Caution indicates a hazardous situation that, if not avoided, may cause minor or moderate personal injury or property damage.

Additional precautionary statements (“IMPORTANT” and “NOTE”) are followed by specific instructions.

### **IMPORTANT**

The word “IMPORTANT” is used to inform the reader of specific procedures where minor machine damage will occur if the procedure is not followed.

### **NOTE**

The word “NOTE” is used to communicate installation, operation, maintenance or servicing information that is important but not hazard related.

In the interest of safety, some general precautions relating to the operation of this machine follow.



## **WARNING**

- **Failure to install, maintain and/or operate this product according to the manufacturer’s instructions may result in conditions which can produce serious injury, death and/or property damage.**
- **Do not repair or replace any part of the product or attempt any servicing unless specifically recommended or published in this Service Manual and unless you understand and have the skills to carry out the servicing.**
- **Whenever ground wires are removed during servicing, these ground wires must be reconnected to ensure that the product is properly grounded and to reduce the risk of fire, electric shock, serious injury or death.**

W006R2



## WARNING

To reduce the risk of electric shock, fire, explosion, serious injury or death:

- Disconnect electric power to the washer before servicing.
- Never start the washer with any guards/panels removed.
- Whenever ground wires are removed during servicing, these ground wires must be reconnected to ensure that the washer is properly grounded.
- Motor not grounded! Disconnect electric power before servicing motor.

W485



## WARNING

Repairs that are made to your products by unqualified persons can result in hazards due to improper assembly or adjustments subjecting you or the inexperienced person making such repairs to the risk of serious injury, electrical shock or death.

W007



## WARNING

If you or an unqualified person perform service on your product, you must assume the responsibility for any personal injury or property damage which may result. The manufacturer will not be responsible for any injury or property damage arising from improper service and/or service procedures.

W008

**NOTE: The WARNINGS and IMPORTANT INSTRUCTIONS appearing in this manual are not meant to cover all possible conditions and situations that may occur. Common sense, caution and care must be exercised when installing, maintaining or operating the washer.**

Always contact your dealer, distributor, service agent or the manufacturer about any problems or conditions you do not understand.

### Locating an Authorized Servicer

Alliance Laundry Systems is not responsible for personal injury or property damage resulting from improper service. Review all service information before beginning repairs.

Warranty service must be performed by an authorized technician, using authorized factory parts. If service is required after the warranty expires, Alliance Laundry Systems also recommends contacting an authorized technician and using authorized factory parts.

# Section 2

## Introduction

### Customer Service

If literature or replacement parts are required, contact the source from whom the machine was purchased or contact Alliance Laundry Systems at (920) 748-3950 for the name and address of the nearest authorized parts distributor.

For technical assistance, call either of the numbers listed below:

(920) 748-3121 Ripon, Wisconsin

+32 56 41 20 54 Wevelgem, Belgium

### Nameplate Location

When calling or writing about your product, be sure to mention model and serial numbers. Model and serial numbers are located on nameplate(s) as shown.

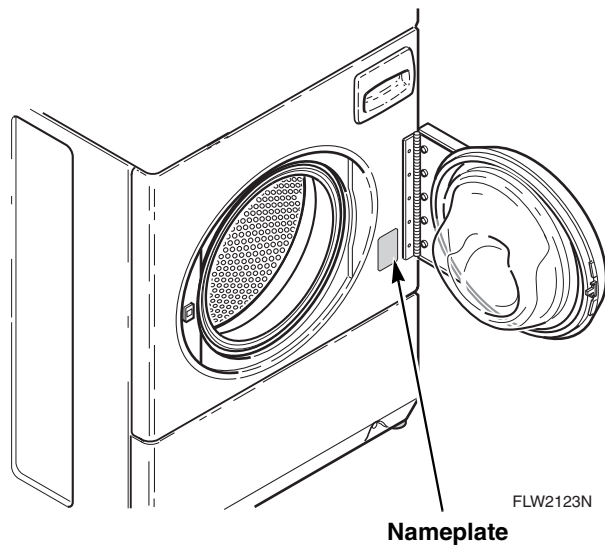

## Introduction

## Model Identification

Information in this manual is applicable to these machines:

AFN50FSP301AW01	FTSA1A*N
AFN51FSP111FN01	FTUA1A*N
AFN51FSP111TN03	FTUA1A*N1102
AFN51FSP301AN01	FTZA1A*N1102
AFN51FSP541RN01	LFN50RSP301NW22
ATZA0A*N1102	LFNA0FSP111TW01
ATZA5A*N1102	LFNA0RSP111TW01
BFN5SFSP111CW01	LTKA5A*N3050
BFN5SFSP111TW01	L TSA0A*N
CFN50FSP111CW01	L TSA0A*N1127
CFN50RSP111CW01	L TSA5A*N
CTZA0A*N1102	L TSA5A*N3000
FTSA0A*N	L TZA0A*N1102
FTSA0A*N3000	ZFN50FSP111CW01
FTSA0A*N3050	ZFN50RSP111CW01
FTSA0A*N3300	ZFN51FSP111CN01

**\* Add Letter To Designate Color. W – White Q – Bisque**



# Theory of Operation (Front Control Shown)

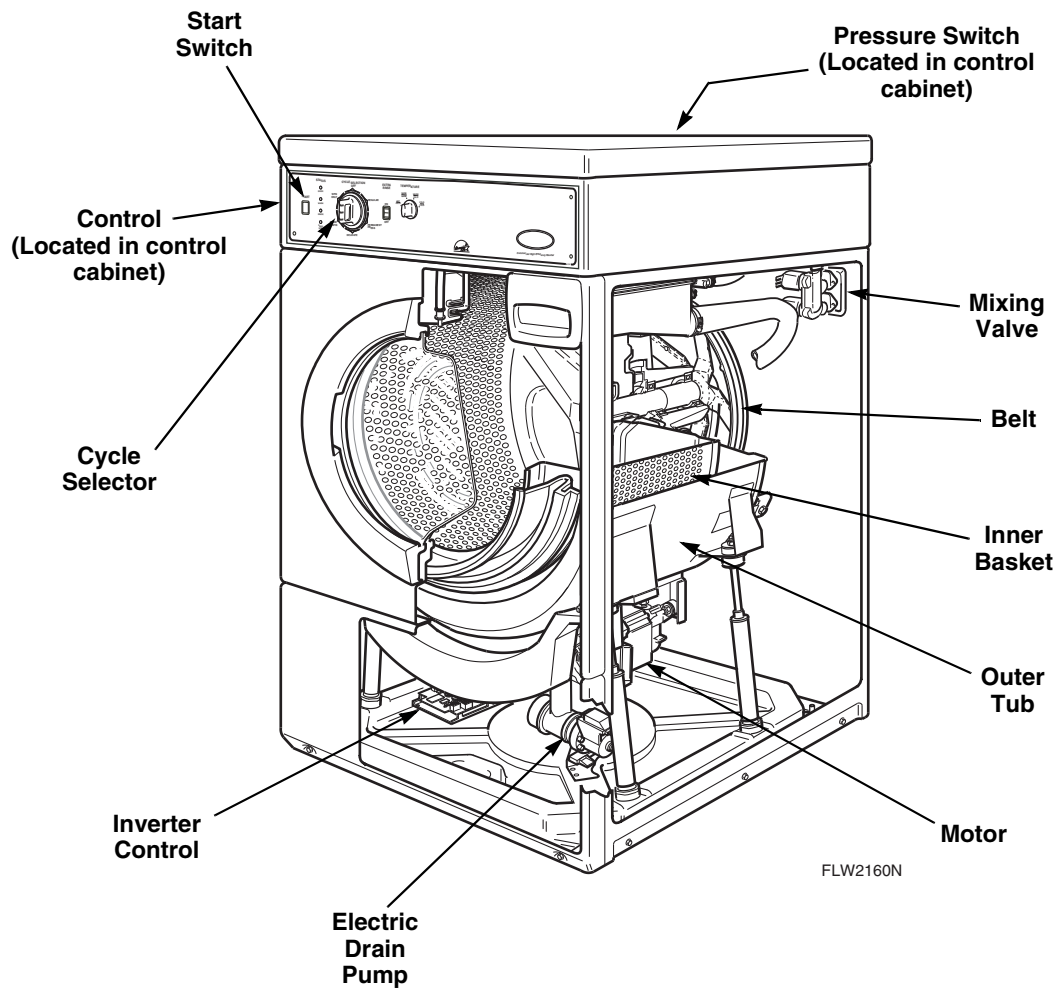

## General

This frontload washer provides some of the same principles of operation as the typical topload washers. It senses water level, it dispenses the desired laundry detergent, agitates the clothes for good cleaning action, pumps the water out of the washer and spins the clothing in preparation for the dryer.

The difference in operation is primarily the rotational washing agitation created for the horizontal basket and drum. This agitation tumbles the clothes in a clockwise, pause, and counter-clockwise direction. This reversing tumbling action provides an efficient washing process and requires less water.

The cycle begins by pressing the start button, which locks the loading door after the vend is satisfied. The type of cycle and water temperature are determined by the temperature selector switch and the cycle select switch.

The inner basket starts agitating during the wash water fill. A column of air is trapped in a pressure bulb and hose. The air pressure continues to increase as the inner basket fills with water until it is great enough to activate the pressure switch which then causes the wash fill to stop.

The regular and perm press agitate cycle tumble the clothing in a clockwise direction for a period of 15 seconds, pauses for nine seconds and then tumbles the clothing in a counterclockwise direction for 15 seconds. This agitation continues until the wash cycle. The machine stops agitating and turns on the pump which removes the wash water.

Upon completion of the wash cycle, the machine goes into two rinse cycles. Fresh cold water is brought into the inner basket via the mixing valve until the pressure switch shuts off the water while agitating. The rinse cycle consists of agitation for a predetermined amount of time, then a spin mode with the pump running while the machine goes into a series of 4 short 500 RPM spins.

After all the rinse cycles have been completed, the washer goes into a final high spin cycle to extract as much water as possible from the clothing to prepare them for the dryer. The spin speeds and duration of this final high spin cycle are determined by the type of wash cycle selected (refer to *Table 1* or *Table 2*).

**NOTE: Washer may not reach 1000 RPM because of an out-of-balance condition. Control may limit speed to 850, 650 or 500 RPM depending on severity of out-of-balance condition.**

**Models Through Serial No. 0911014602**

	Regular	Perm Press	Delicate
650 RPM	3 minutes	4 minutes	4 minutes
1000 RPM	3 minutes	2 minutes	0 minutes

Table 1

**Models Starting Serial No. 0911014603**

	Regular	Perm Press	Delicate
500 RPM	0 minutes	0 minutes	4 minutes
650 RPM	3 minutes	6 minutes	0 minutes
1000 RPM	3 minutes	0 minutes	0 minutes

Table 2

## Technical

The basic operational system of this washer consists of the control, temperature switch, inverter control, pressure switch, water valves, electric pump, A.C. motor and cycle select switch.

The control performs all timing functions like the timer in a topload washer.

The inverter control uses a speed sensor on the motor to measure the drum RPM. Before entering any spin step, the inverter control measures the RPM of motor to sense out-of-balance. The inverter control will try to redistribute the clothes if an out-of-balance condition exists; the inverter control will limit the spin speed to several speeds depending on the severity of the out-of-balance condition. If the out-of-balance condition is severe enough, the inverter control will limit speed to 90 RPM and will not spin.

**NOTE: An additional out-of-balance switch is used to detect any out-of-balance condition during spins. If this switch opens during a spin step, the inverter control immediately stops and then restarts the spin.**

# Section 3

## Troubleshooting



### WARNING

To reduce the risk of electric shock, fire, explosion, serious injury or death:

- Disconnect electric power to the washer before servicing.
- Never start the washer with any guards/panels removed.
- Whenever ground wires are removed during servicing, these ground wires must be reconnected to ensure that the washer is properly grounded.
- Motor not grounded! Disconnect electric power before servicing motor.

W485

## 1. Motor Circuit

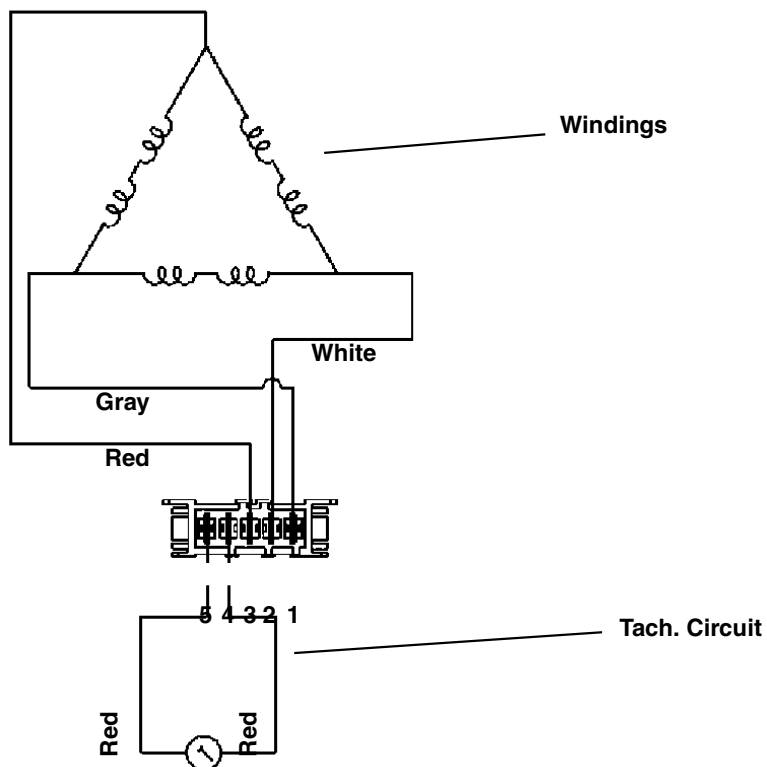

### Resistance Values:

Tachometer Circuit:  
Terminals 4–5  
Approx. **115** ohms

### Windings:

Terminals 1–2, 2–3, 1–3  
Approx. **4.5** ohms

## 2. Troubleshooting Knocking Noise

If a frontload washer produces a noise similar to a knock on a door, it might be due to a flat spot on the belt. The knocking sound is made when the flat spot hits the pulley. The knocking may occur

during a pulse spin and fade after reaching a higher RPM.

To correct this condition, replace the belt.



## WARNING

To reduce the risk of electric shock, fire, explosion, serious injury or death:

- Disconnect electric power to the washer before servicing.
- Never start the washer with any guards/panels removed.
- Whenever ground wires are removed during servicing, these ground wires must be reconnected to ensure that the washer is properly grounded.
- Motor not grounded! Disconnect electric power before servicing motor.

W485

### 3. No Spin Due to Out-of-Balance Switch Wiring Problem Starting Serial Nos. Beginning 0307

A “no spin” condition could be the result of an open circuit in the wire harness or out-of-balance switch. First, check that the harness is still connected to the out-of-balance switch. The out-of-balance switch is a **normally closed switch**. (continued)

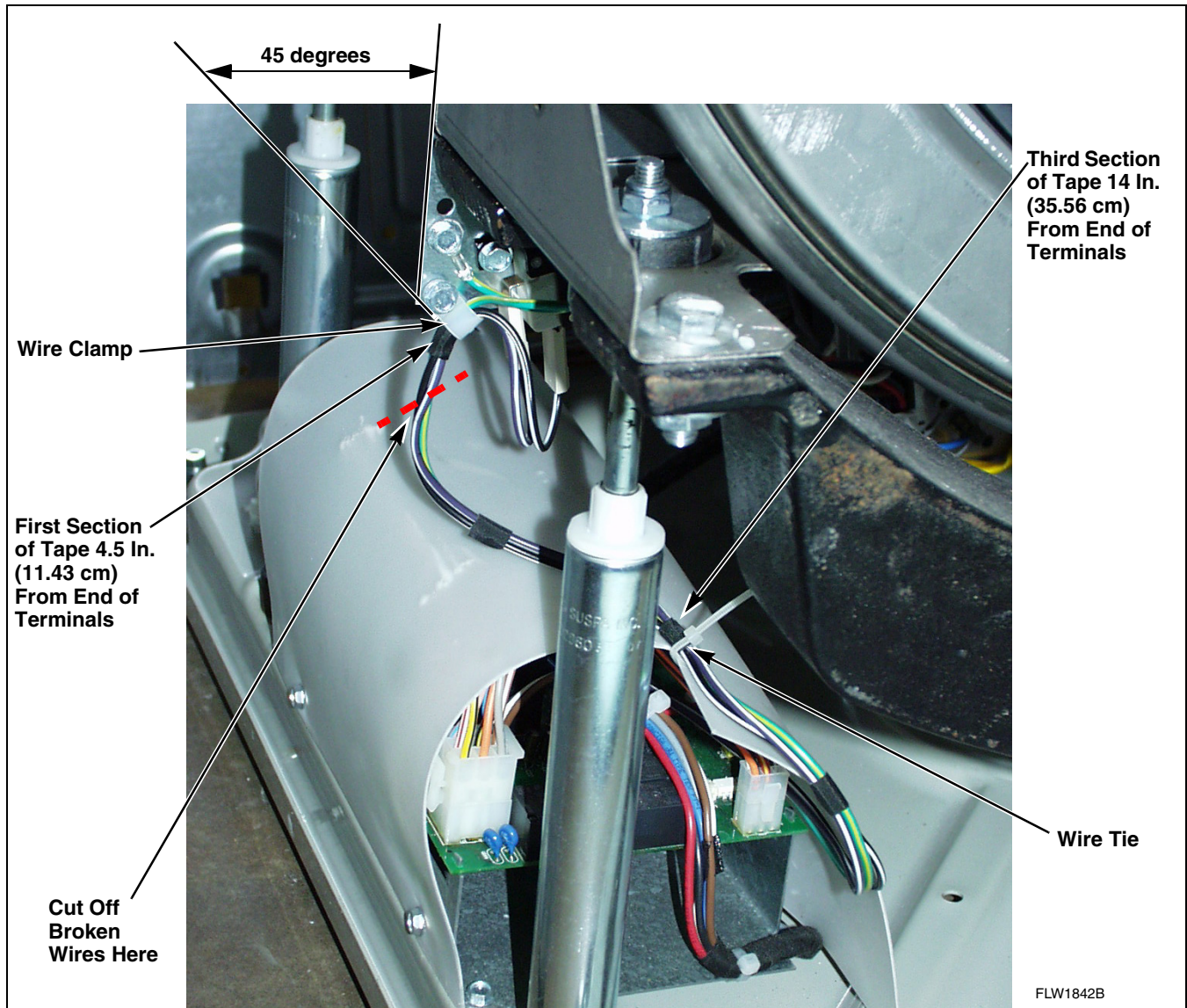

Figure 1



## WARNING

**To reduce the risk of electric shock, fire, explosion, serious injury or death:**

- **Disconnect electric power to the washer before servicing.**
- **Never start the washer with any guards/panels removed.**
- **Whenever ground wires are removed during servicing, these ground wires must be reconnected to ensure that the washer is properly grounded.**
- **Motor not grounded! Disconnect electric power before servicing motor.**

W485

If broken wires are found at the out-of-balance switch wire support, cut off portion of wires as shown in *Figure 10* and add new UL approved terminals.

- a. To test the electrical circuit, disconnect electrical power to the washer.
- b. Remove the “H1” connector from the inverter control assembly.
- c. Use an Ohm meter to check the black/white to violet/white wires. Circuit should read closed. An open reading indicates a bad switch or wire harness problem.
- d. Flex the harness at the plastic wire clamp and test continuity. If the base wire harness has an open circuit it **MUST** be replaced or the broken wires must be repaired with UL approved terminals.
- e. After replacing or repairing the wire harness, wrap electrical tape around wires in two locations as indicated below and in *Figure 10*. Then secure the harness wires to the original factory locations using clamp and wire tie. Refer to *Figure 10*.
  - (1) The plastic wire clamp should be angled toward the switch at 45 degrees.
  - (2) The clamp should wrap around the first section of tape on the harness, which should be placed approximately 4.5 inches (11.43 cm) from end of terminals.
  - (3) The harness should be secured to the inverter control shield with a wire tie.
  - (4) The tie should wrap around the third section of tape on the harness, which should be placed approximately 14 inches (35.56 cm) from end of terminals. Refer to *Figure 10*.

### 4. Troubleshooting LEDs on Washer Inverter Controls Starting Machine Serial No. 0911014603

There are three LEDs on the control to assist with troubleshooting (refer to *Figure 11*):

- Green LED on constant = 5VDC power supply present
- Green LED flashing one second on/one second off = inverter control power up
- Red LED flashing four times/second = inverter control is communicating with front end control

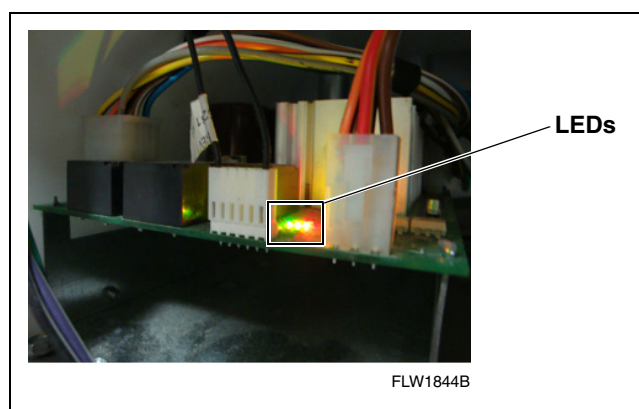

Figure 2

### 5. No Spin (Washer)

A no spin condition is not caused by intermittent operation of the motor or motor control (inverter assembly). **DO NOT** replace these components for no spin complaints if the unit passes the following procedure:



## WARNING

To reduce the risk of electric shock, fire, explosion, serious injury or death:

- Disconnect electric power to the washer before servicing.
- Never start the washer with any guards/panels removed.
- Whenever ground wires are removed during servicing, these ground wires must be reconnected to ensure that the washer is properly grounded.
- Motor not grounded! Disconnect electric power before servicing motor.

W485

### 5. No Spin (continued)

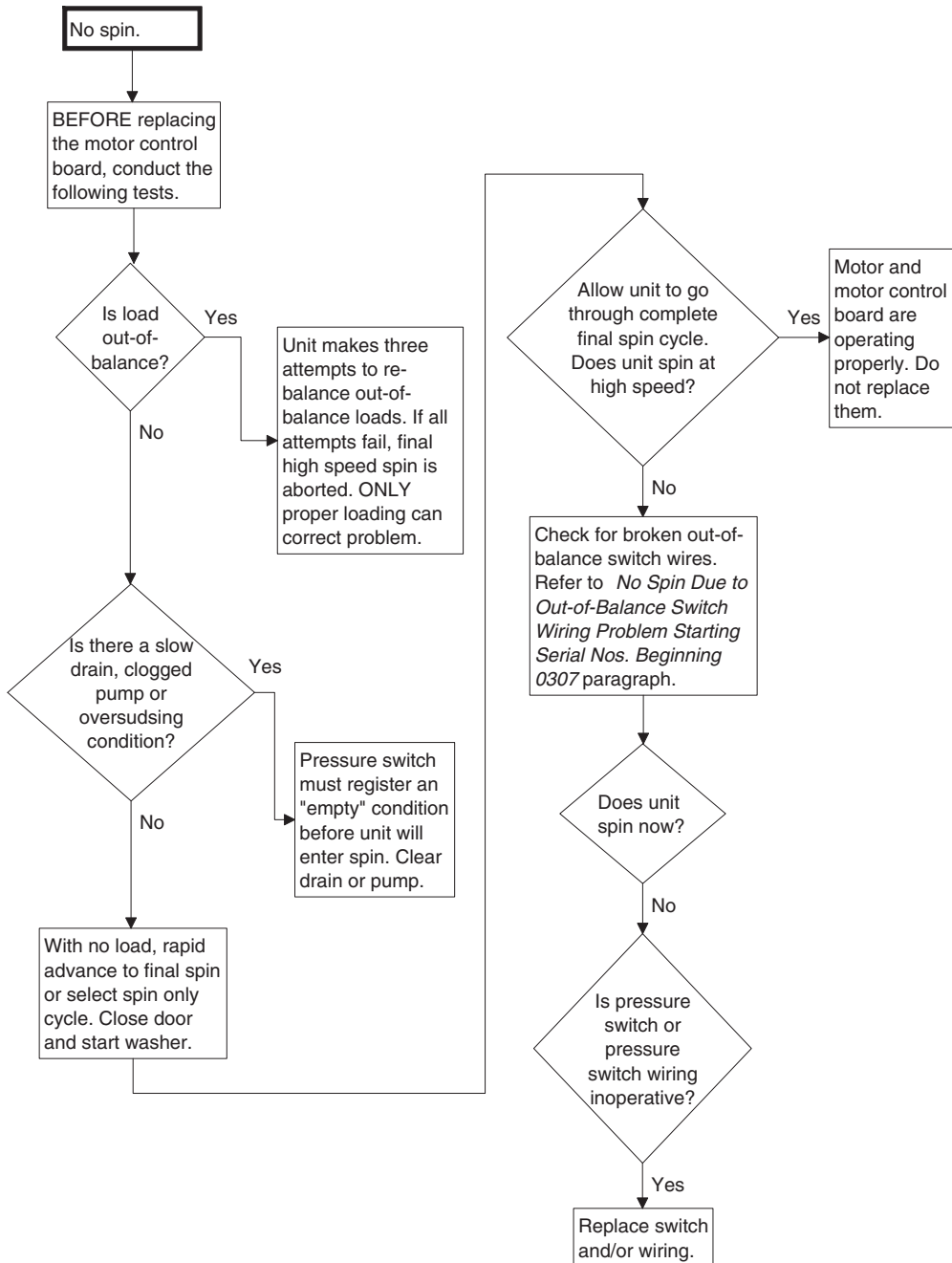

FLW1789S



## WARNING

**To reduce the risk of electric shock, fire, explosion, serious injury or death:**

- **Disconnect electric power to the washer before servicing.**
- **Never start the washer with any guards/panels removed.**
- **Whenever ground wires are removed during servicing, these ground wires must be reconnected to ensure that the washer is properly grounded.**
- **Motor not grounded! Disconnect electric power before servicing motor.**

W485

## 6. Troubleshooting Shock Absorbers

A squeaking noise, oil seen on the base of the washer, or an out-of-balance condition may mean one or more shock absorbers need to be replaced.

To determine if there is an inoperative shock:

1. Remove front access panel.
2. Check height of rod or rod spacing above shock.  
If all four shocks are uniform and have about two inches of rod showing when basket is empty, shocks don't need replacing. Refer to *Figure 12*.  
If one or more shocks is showing less than two inches of rod, then an internal spring has broken and all four shocks should be replaced.
3. Check base of washer below shock absorbers for grease or oil. Shocks are not oil filled. Any oil is from grease used internally to lubricate damper of shock. A small amount of grease/oil on base is normal and doesn't indicate failure. A large amount of grease/oil indicates a shock that might fail soon. Do not replace shock until the internal spring has broken as described in Step 2.





## WARNING

To reduce the risk of electric shock, fire, explosion, serious injury or death:

- Disconnect electric power to the washer before servicing.
- Never start the washer with any guards/panels removed.
- Whenever ground wires are removed during servicing, these ground wires must be reconnected to ensure that the washer is properly grounded.
- Motor not grounded! Disconnect electric power before servicing motor.

W485

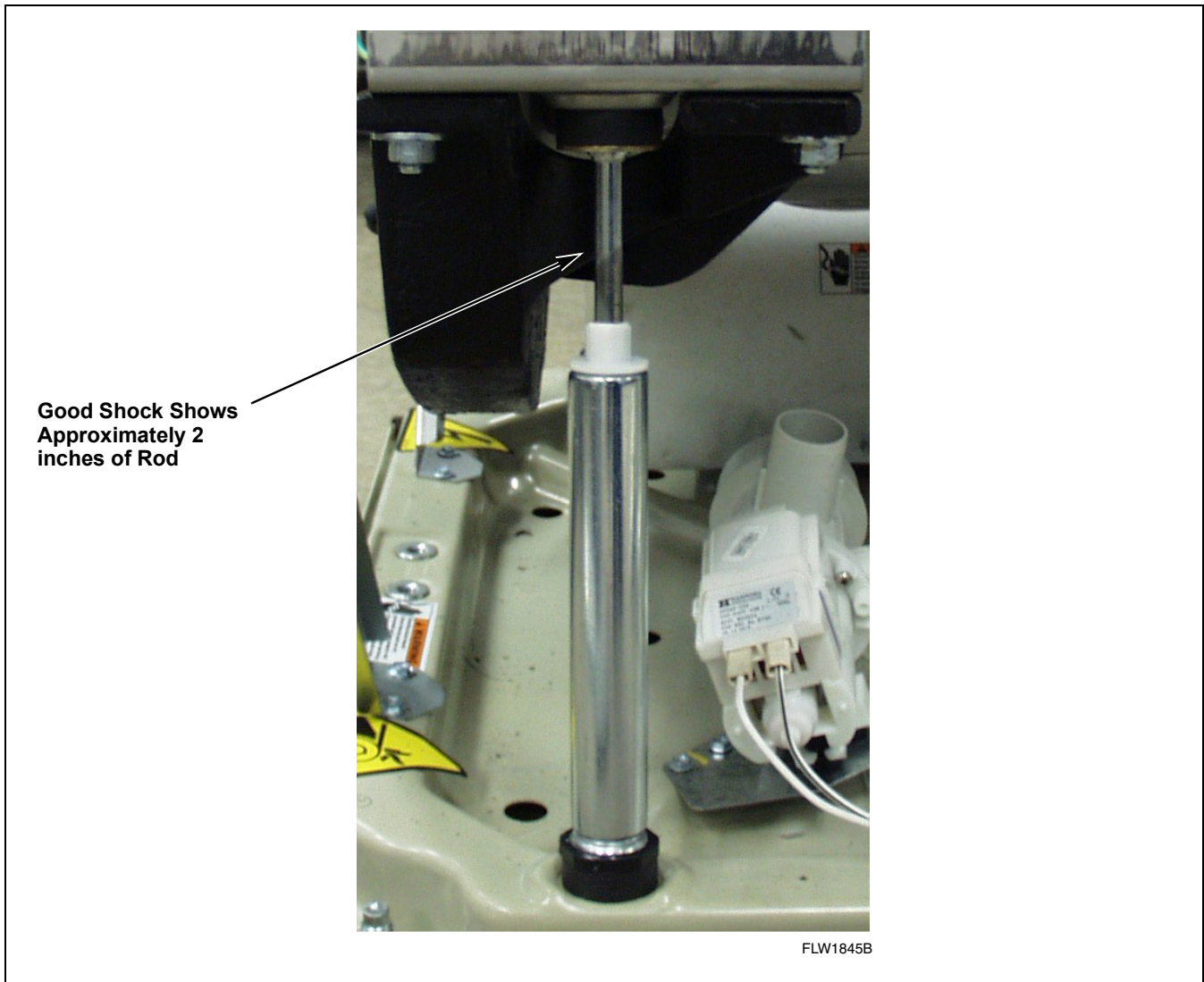



Figure 3



	WARNING
<p><b>To reduce the risk of electric shock, fire, explosion, serious injury or death:</b></p> <ul style="list-style-type: none"> <li>• <b>Disconnect electric power to the washer before servicing.</b></li> <li>• <b>Never start the washer with any guards/panels removed.</b></li> <li>• <b>Whenever ground wires are removed during servicing, these ground wires must be reconnected to ensure that the washer is properly grounded.</b></li> <li>• <b>Motor not grounded! Disconnect electric power before servicing motor.</b></li> </ul>	
W485	

## 7. Error Code Listing

### Error Conditions

If any of the following errors occur, the control enters Error Mode. For all fatal errors, the control will terminate the current cycle, turn off all outputs, and flash two LEDs one second on/one second off to indicate the error.

Motor Failure Error.	If the control receives the motor failure signal from the motor control, the control will enter Error Mode. The control will turn off all outputs and flash the DOOR and FINAL SPIN LEDs one second on/one second off to indicate a motor failure error. This is a fatal error. The machine must be unpowered to clear this error.
Fill Error.	If the control receives no full input from the pressure switch indicating the cylinder is full within 30 minutes of starting the fill, the control will enter Error Mode. The control will turn off all outputs and flash the WASH and DOOR LEDs one second on/one second off to indicate a fill error. This is a fatal error. The machine must be unpowered to clear this error.
Door Open Error.	If the control senses the door open during Run Mode, the control will enter Error Mode. The control will turn off all outputs and flash the WASH and RINSE LEDs one second on/one second off to indicate a door open error. This is a fatal error. The machine must be unpowered to clear this error.
Door Lock/Unlock Error.	<p>If the door doesn't lock in 15 seconds in Door Locking Mode or the door doesn't unlock in 3 minutes in Door Unlocking Mode, the control will enter Door Lock Error Mode. The control will turn off all outputs and flash the DOOR LED one second on/one second off to indicate a door lock/unlock error.</p> <p>To clear this error in Door Locked Mode the door must either open or lock. If the door locks, the cycle will start normally. If the door opens, the control will revert back to Start Mode.</p> <p>To clear this error in Door Unlocking Mode the door must unlock or open. If the door unlocks or opens, the control will enter End of Cycle Mode.</p>
SPI Communications Error.	This error occurs when there is a problem with communications between the front-end control and the motor control. The control will turn off all outputs and flash the FINAL SPIN and RINSE LEDs one second on/one second off to indicate an SPI communications error. This is a fatal error. The machine must be powered down at this point.
Open/Shorted Temperature Sensor Error (Models equipped with heater)	Any time the control senses a temperature less than 32°F (0°C) or greater than 212°F (100°C) while heating, the control will turn off the heater output and not attempt to heat. The control will continue and finish the cycle normally. At the end of the cycle the control will flash the HEATING LED one-second on/one second off to indicate an open/shorted temperature sensor error. This error will be cleared when the door is opened at the end of the cycle.

### 8. Washer Will Not Start – No LEDs/Lights Lit (No response to start switch)

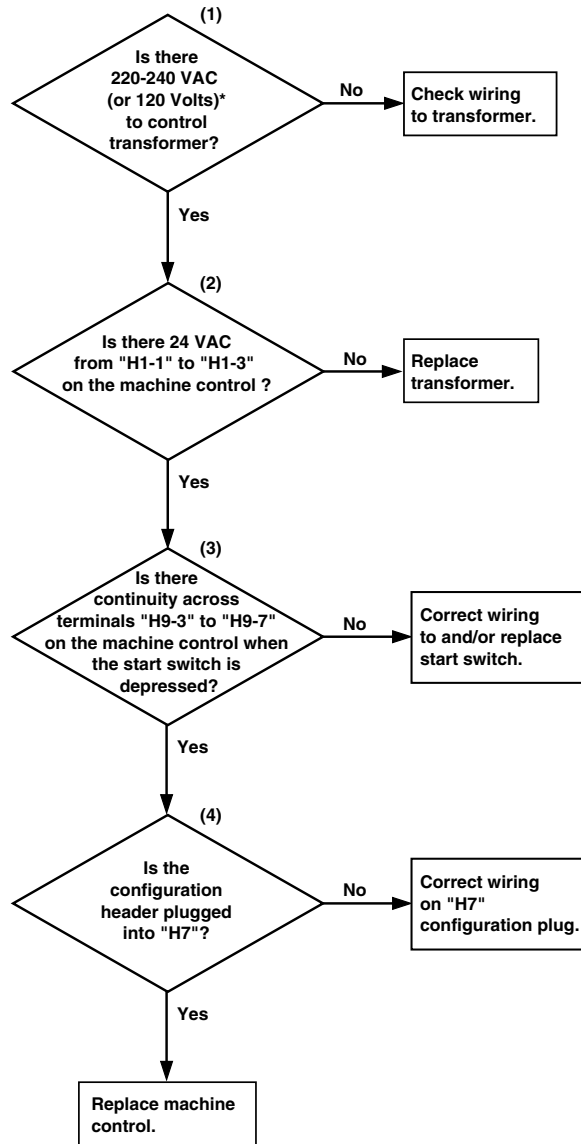

\*Refer to machine serial plate for correct voltage.

FLW1727S

# Washer Will Not Start – No LEDs/Lights Lit (No response to start switch)

SCHEMATIC DIAGRAM

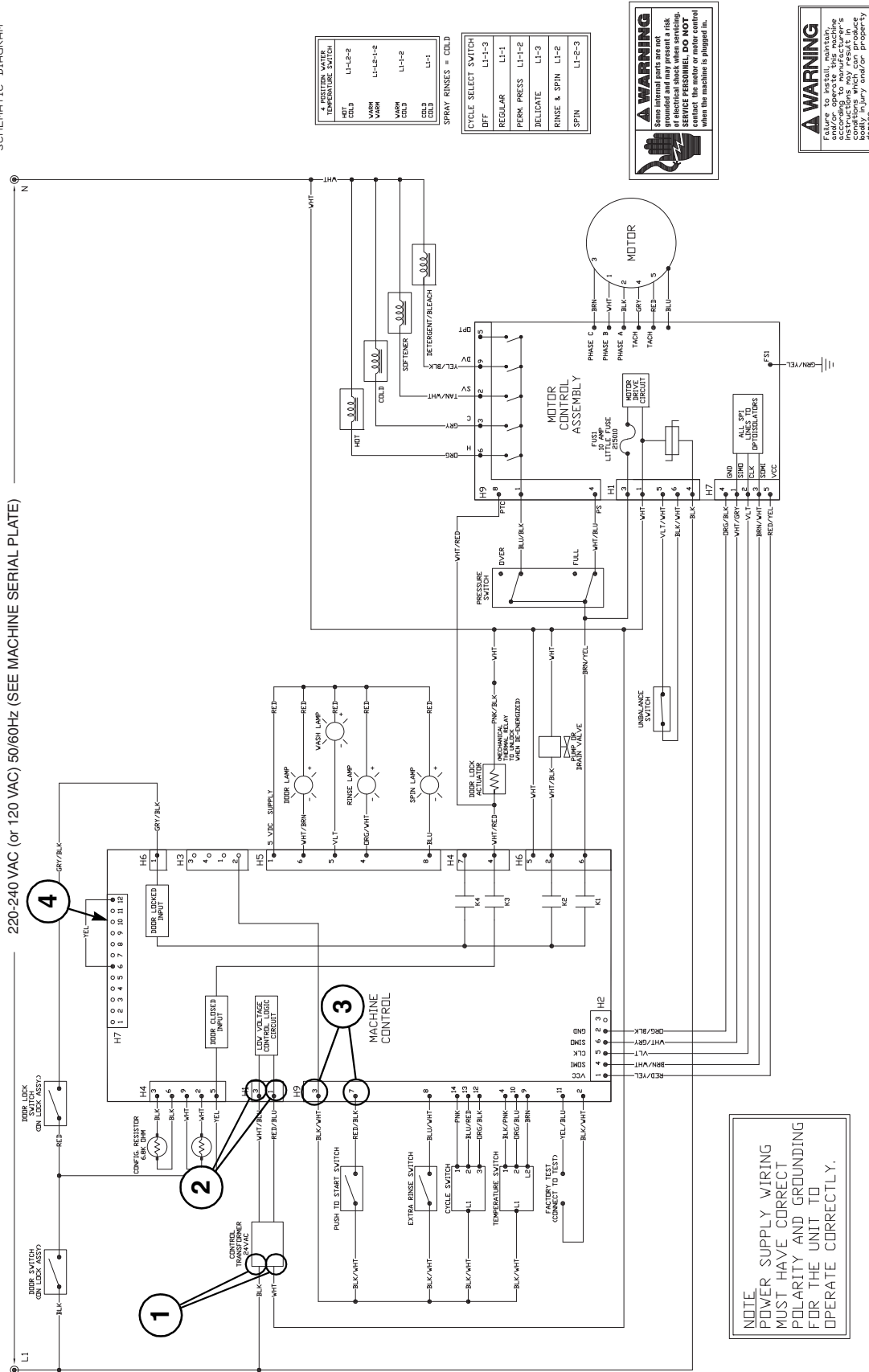

### 9. Washer Will Not Start – Door Open Error (Wash/Rinse LEDs Flashing – Door must be closed and attempting to lock)

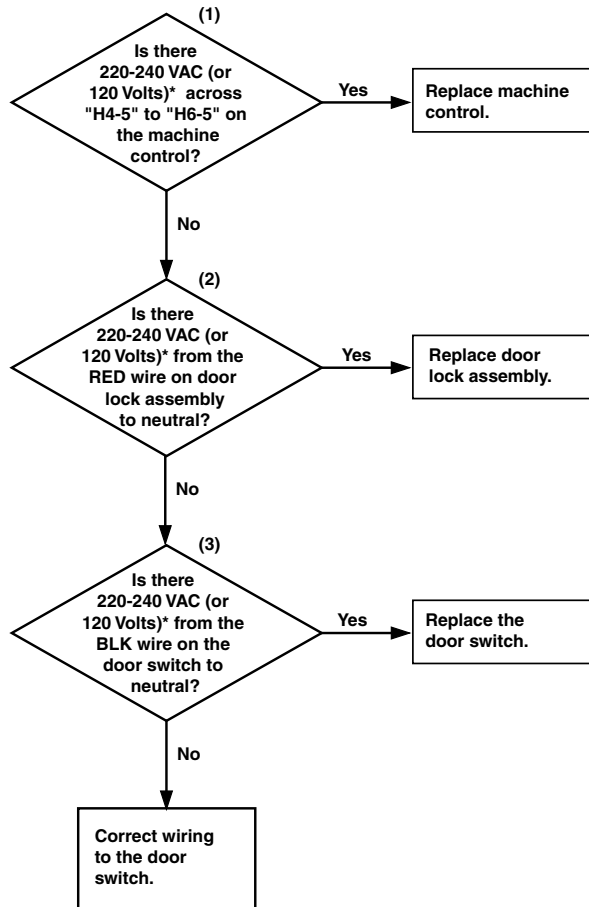

\*Refer to machine serial plate for correct voltage.

FLW1770S



# 10. Washer Will Not Start – No Door Lock (Door LED Flashing)

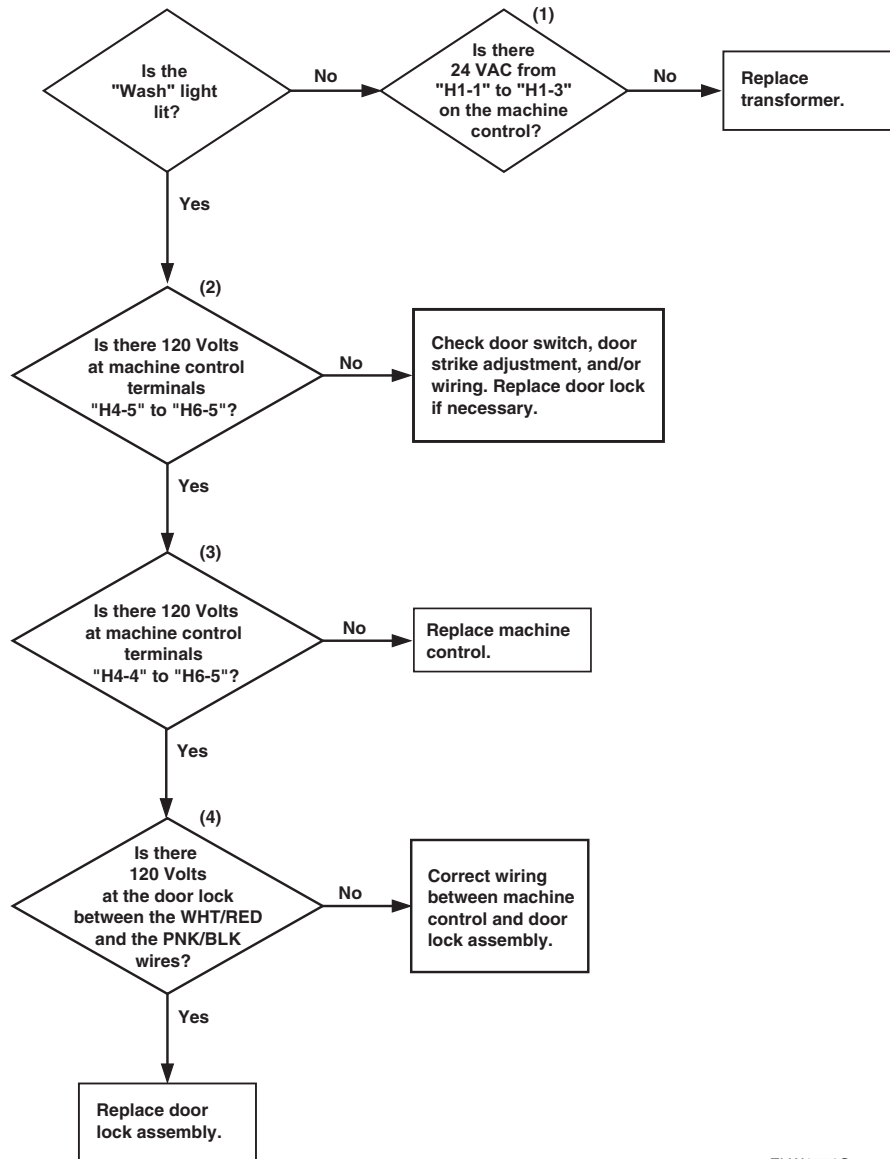

FLW1776S

# Washer Will Not Start – No Door Lock (Door LED Flashing)

SCHEMATIC DIAGRAM

220-240 VAC (or 120 VAC) 50/60Hz (SEE MACHINE SERIAL PLATE)

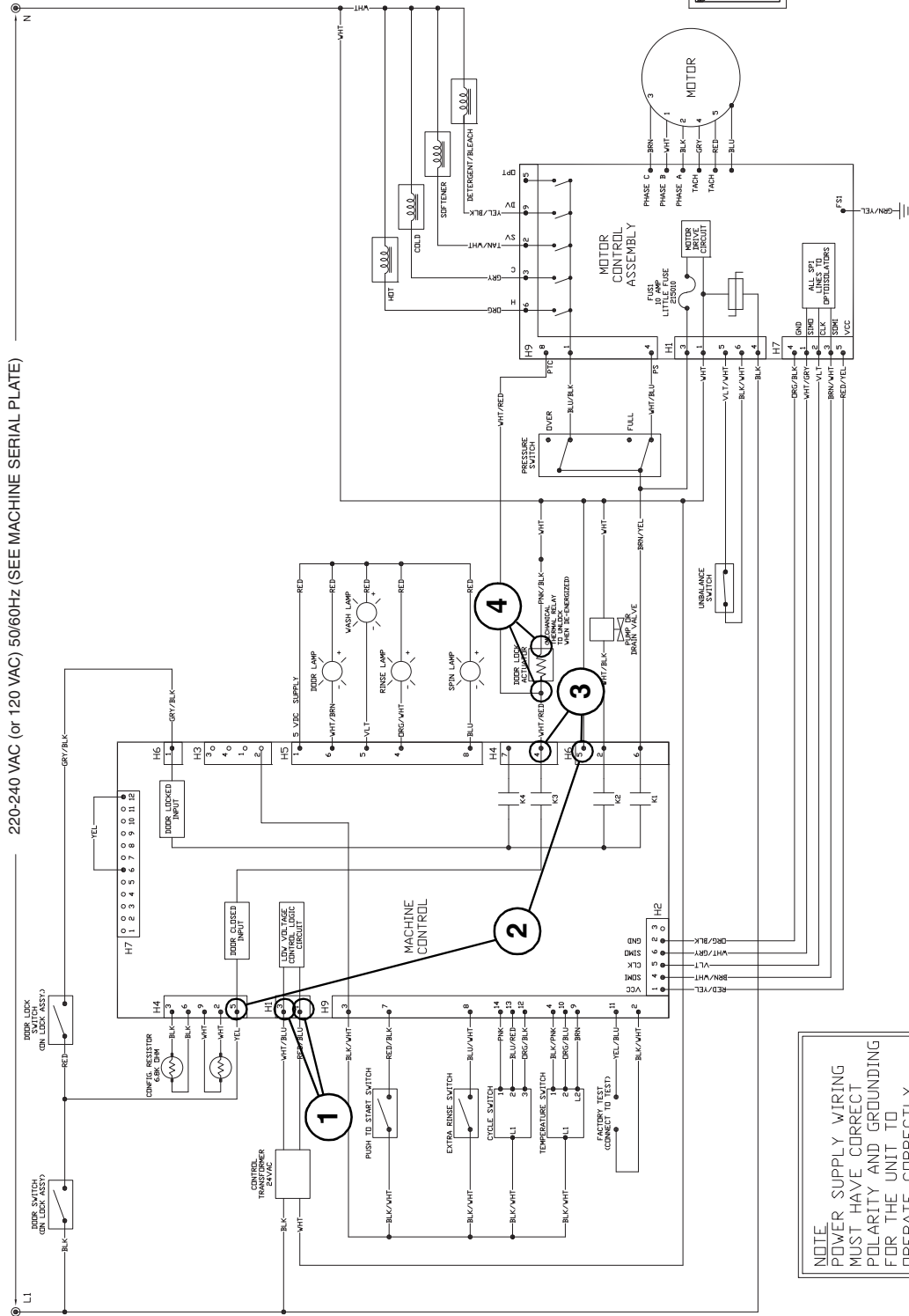

CYCLE SELECT SWITCH	
HOT	L1-L2-2
COLD	L1-L2-1
WASH	L1-L2-1-2
RINSE	L1-2
COLD	L1-1
SPRAY RINSESS = COLD	

CYCLE SELECT SWITCH	
DIFF	L1-1-3
REGULAR	L1-1
PERK PRESS	L1-1-2
DELICATE	L1-2
RINSE & SPIN	L1-2
SPIN	L1-2-3

**WARNING**  
Some internal parts are not designed to be repaired. Failure to follow these instructions could result in electrical shock when servicing. **DO NOT** attempt to repair or replace any internal components unless you are qualified and the unit is unplugged.

**WARNING**  
Failure to install, maintain, or use this unit properly according to manufacturer's instructions could result in conditions which can produce personal injury and/or property damage.

**NOTE:** POWER SUPPLY WIRING MUST HAVE CORRECT POLARITY AND GROUNDING FOR THE UNIT TO OPERATE CORRECTLY.

## 11. Motor Will Not Run (Door/Final Spin LEDs Flashing)

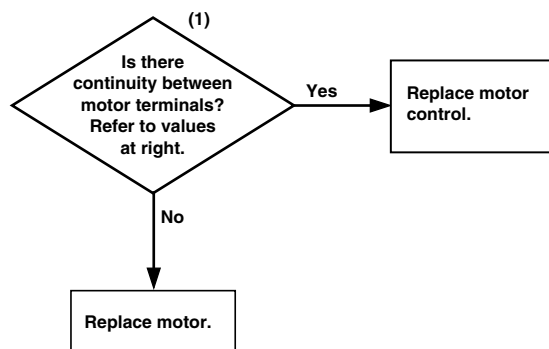

**Motor Resistance Values:**  
**Tach. Circuit:** Approx. 115 ohms (Terminals 4-5)  
**Windings:** Approx. 4 - 5 ohms (Terminals 1-2, 1-3, 2-3)

FLW1712S



# Motor Will Not Run (Door/Final Spin LEDs Flashing)

SCHEMATIC DIAGRAM

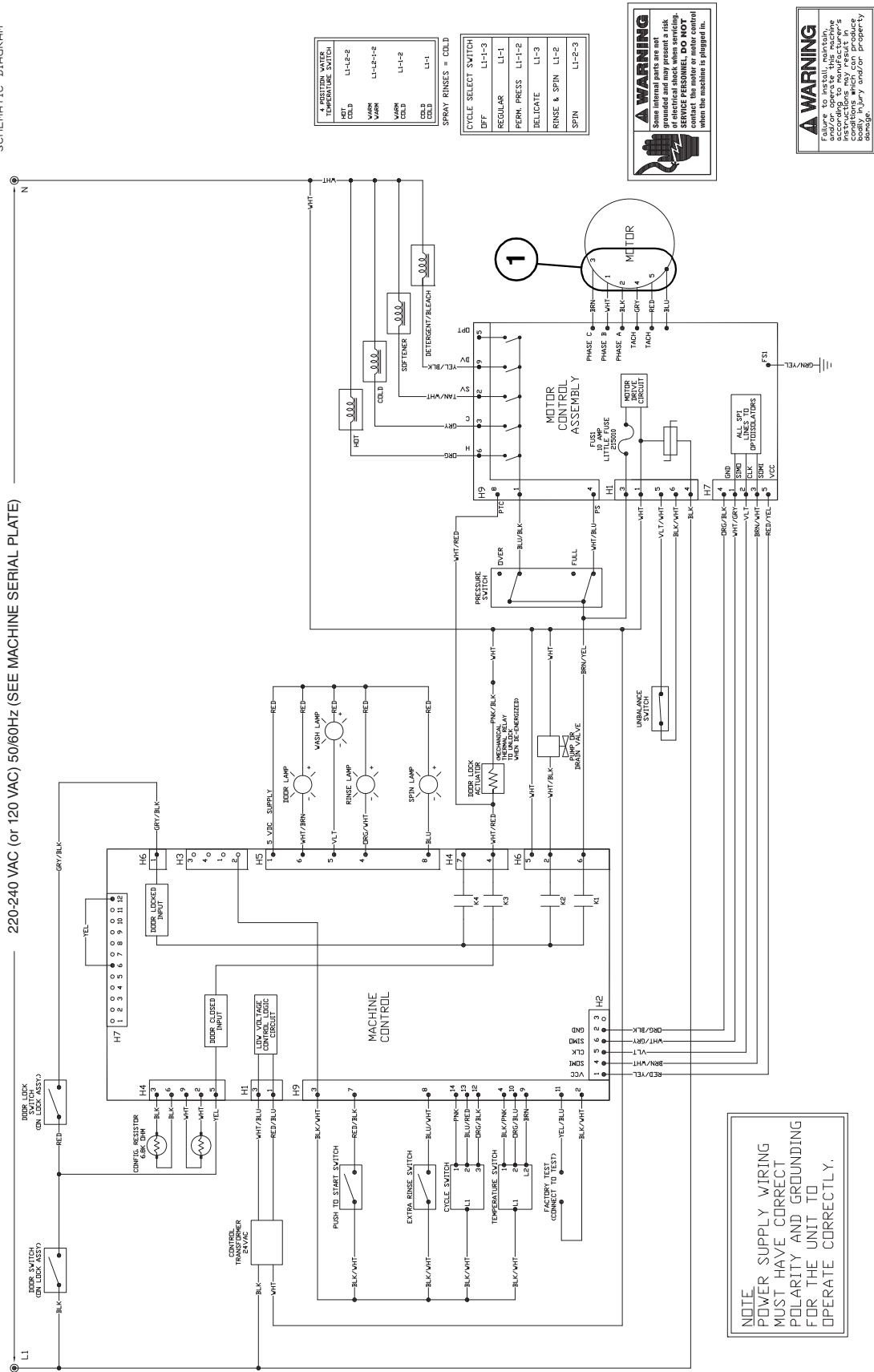

220-240 VAC (or 120 VAC) 50/60Hz (SEE MACHINE SERIAL PLATE)

TEMPERATURE SELECT SWITCH	
HOT	L1-L2
COLD	L1-L2
WARM	L1-L2-L3
WARM	L1-L2-L3
COLD	L1-L2
COLD	L1
SPRAY RINSES = COLD	

CYCLE SELECT SWITCH	
DEF	L1-L3
REGULAR	L1-1
PERM. PRESS	L1-1-2
DELICATE	L1-3
RINSE & SPIN	L1-2
SPIN	L1-2-3

**WARNING**  
Some internal parts are not to be touched. Failure to follow these instructions could result in electrical shock when servicing. **DO NOT** touch internal parts when the machine is plugged in.

**WARNING**  
Failure to install, maintain, or repair this unit according to manufacturer's instructions could result in conditions which can produce personal injury and/or property damage.

**NOTE:**  
POWER SUPPLY WIRING MUST HAVE CORRECT POLARITY AND GROUNDING FOR THE UNIT TO OPERATE CORRECTLY.

## 12. Washer Will Not Fill – No Communication Error (Wash/Door LEDs Flashing)

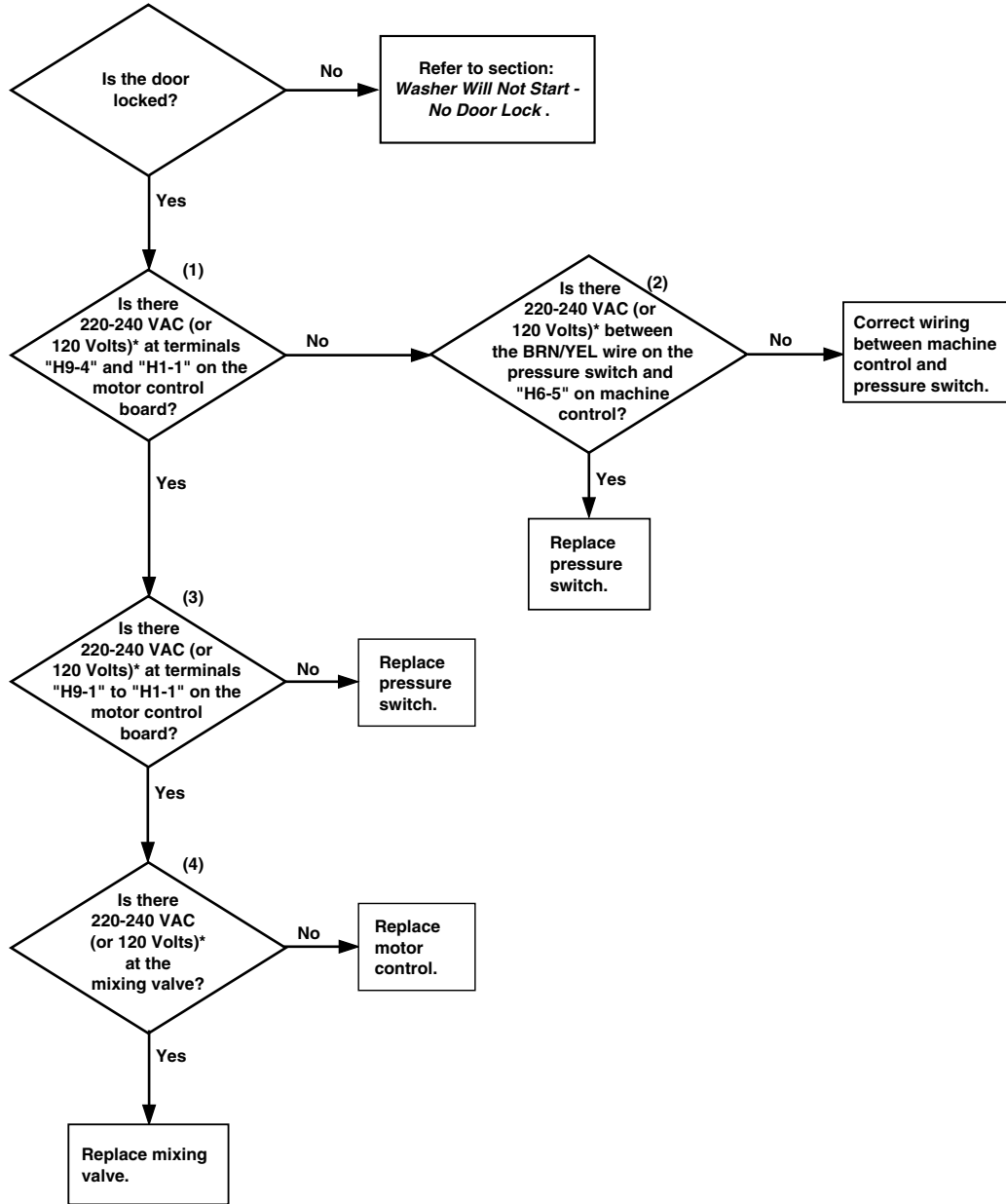

\*Refer to machine serial plate for correct voltage.

FLW1730S



# 13. Washer Overflows

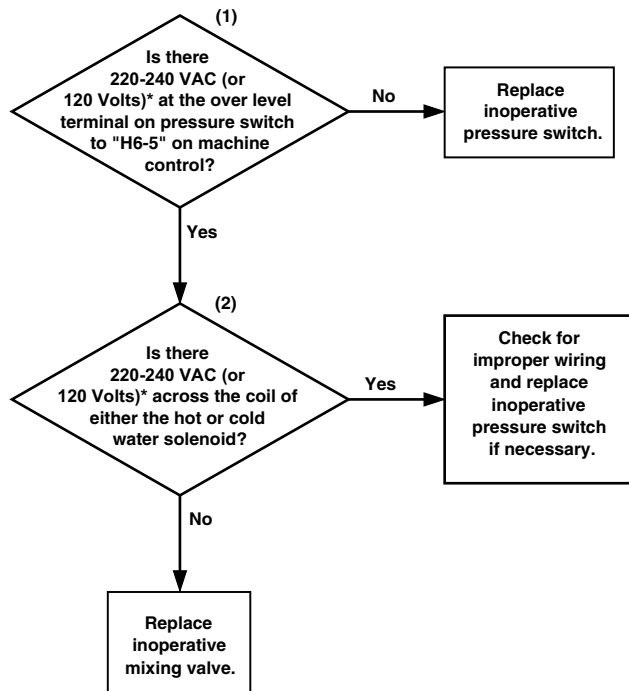

FLW1691S

\*Refer to machine serial plate for correct voltage.



# 14. Pump Does Not Operate

**NOTE: Check at beginning of spin/drain portion of cycle.**

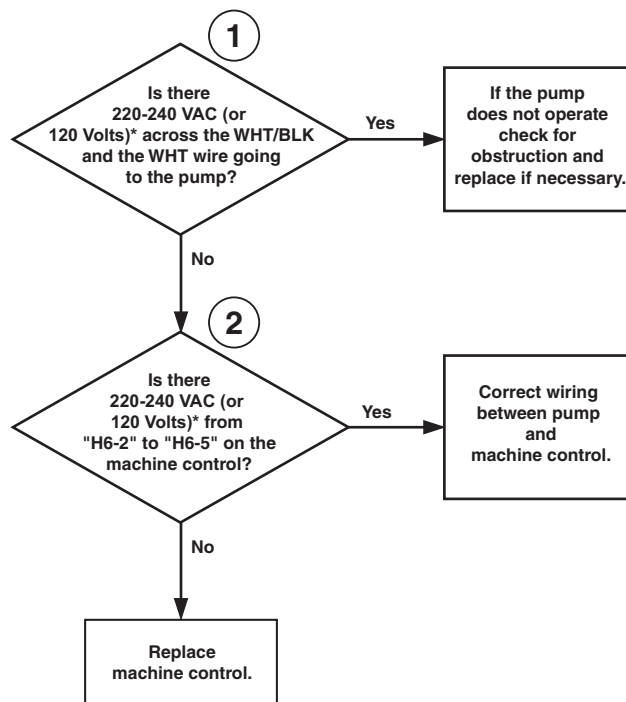

FLW1692S

\*Refer to machine serial plate for correct voltage.

# Pump Does Not Operate

SCHEMATIC DIAGRAM

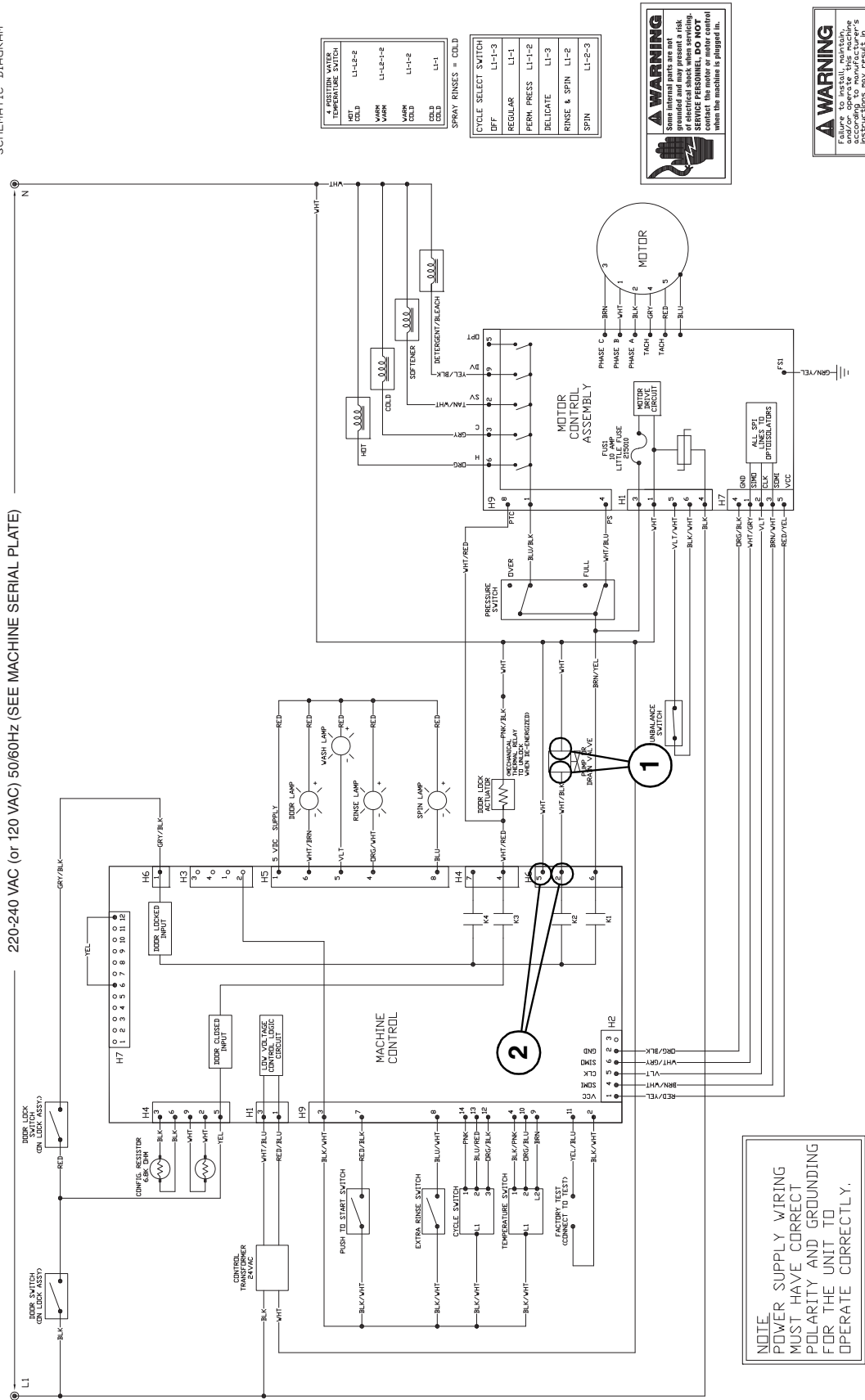

220-240 VAC (or 120 VAC) 50/60Hz (SEE MACHINE SERIAL PLATE)

**NOTE:**  
POWER SUPPLY WIRING MUST HAVE CORRECT POLARITY AND GROUNDING FOR THE UNIT TO OPERATE CORRECTLY.

### 15. Serial Communication Error (Final Spin/Rinse LEDs Flashing)

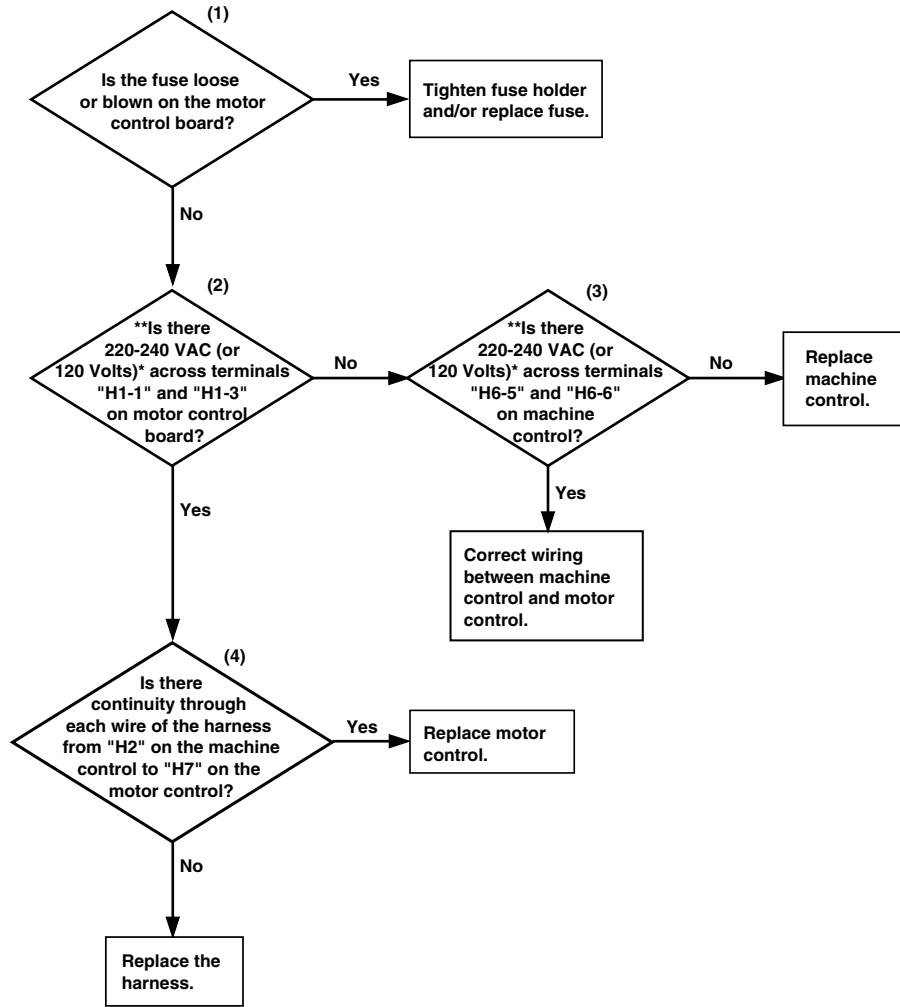

\*Refer to machine serial plate for correct voltage.

\*\*NOTE: Machine must be restarted to check voltage. Voltage is intermittently present for the first 15 seconds until error mode is displayed.

FLW1731S





## 16. Washer Will Not Heat – Open/Shorted Temperature Sensor (Heating LED flashing at end of cycle) (Models equipped with heater)

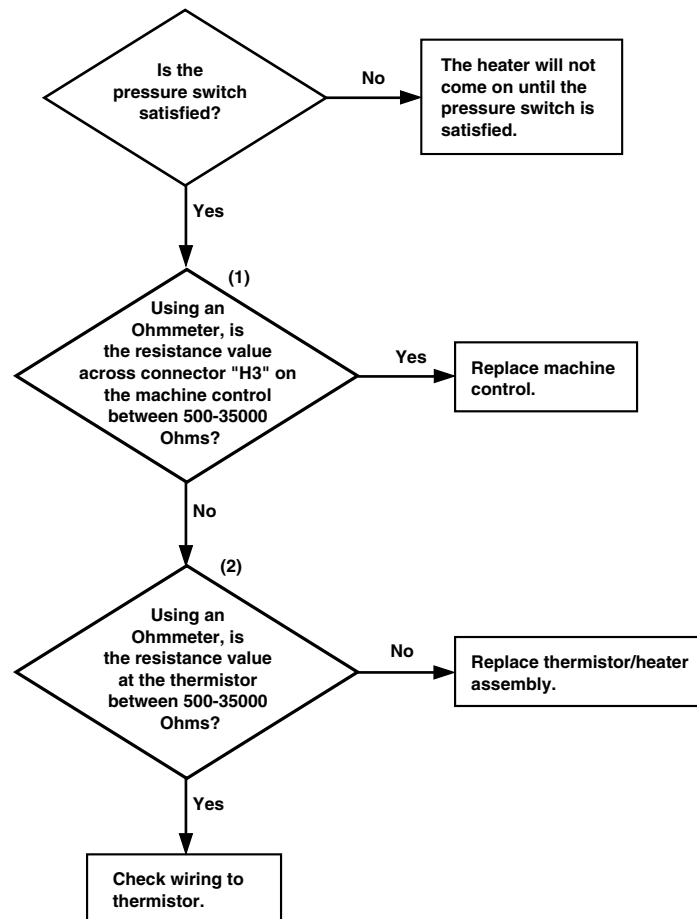

FLW1723S

# Washer Will Not Heat – Open/Shorted Temperature Sensor (Heating LED Flashing at End of Cycle) (Models equipped with heater)

SCHEMATIC DIAGRAM

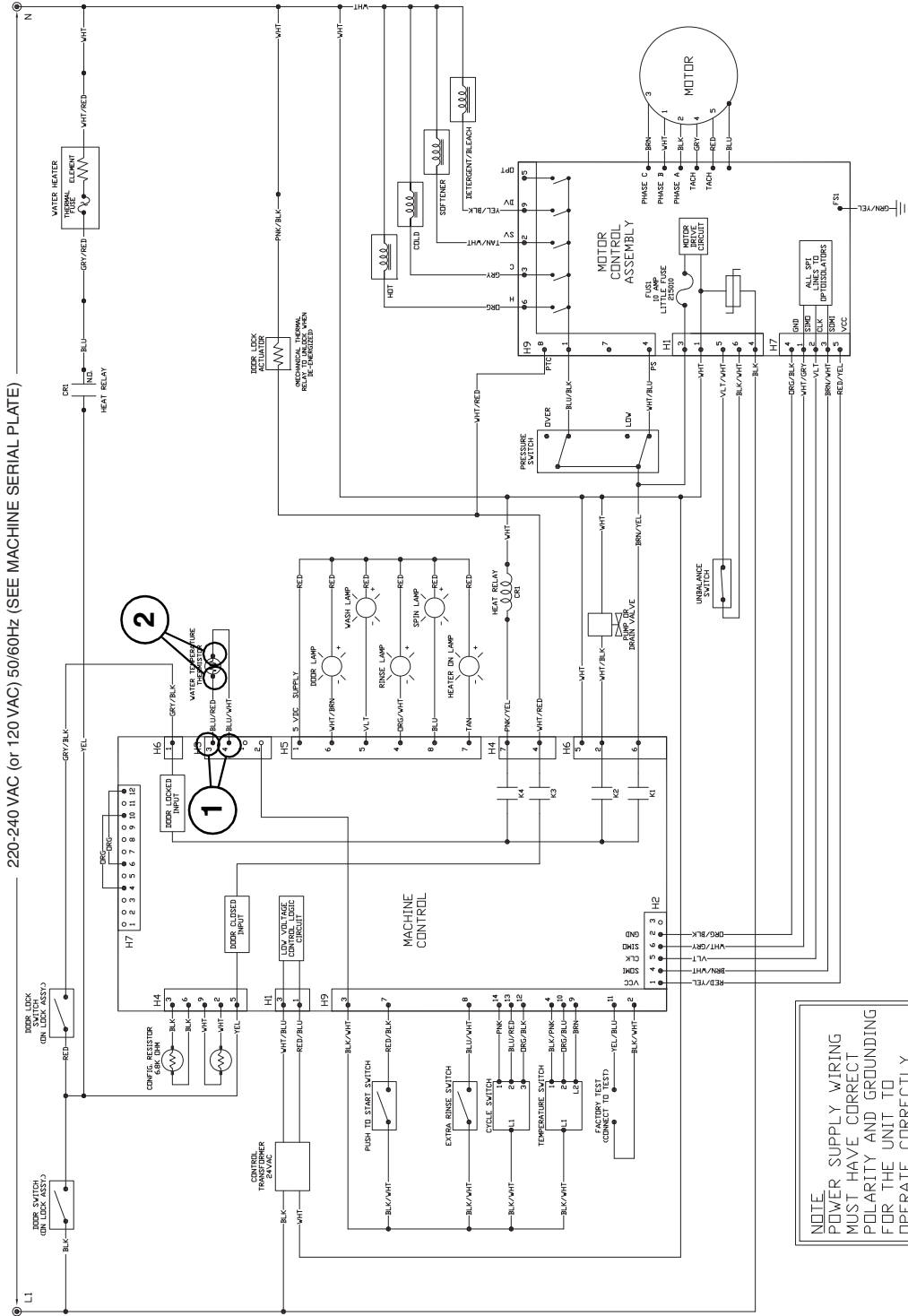

**WARNING**  
Some internal parts are not provided and may present a risk of injury. For more information, contact the manufacturer's SERVICE PERSONNEL. **DO NOT** attempt to repair or disassemble the motor or motor control assembly unless the machine is plugged in.

**WARNING**  
Failure to install, maintain, or operate this equipment according to manufacturer's instructions may result in property damage, personal injury, or death.

**NOTE**  
POWER SUPPLY WIRING MUST HAVE CORRECT POLARITY AND GROUNDING FOR THE UNIT TO OPERATE CORRECTLY.

## 17. Washer Will Not Heat (Models equipped with heater)



FLW1732S

# Washer Will Not Heat (Models equipped with heater)

SCHEMATIC DIAGRAM

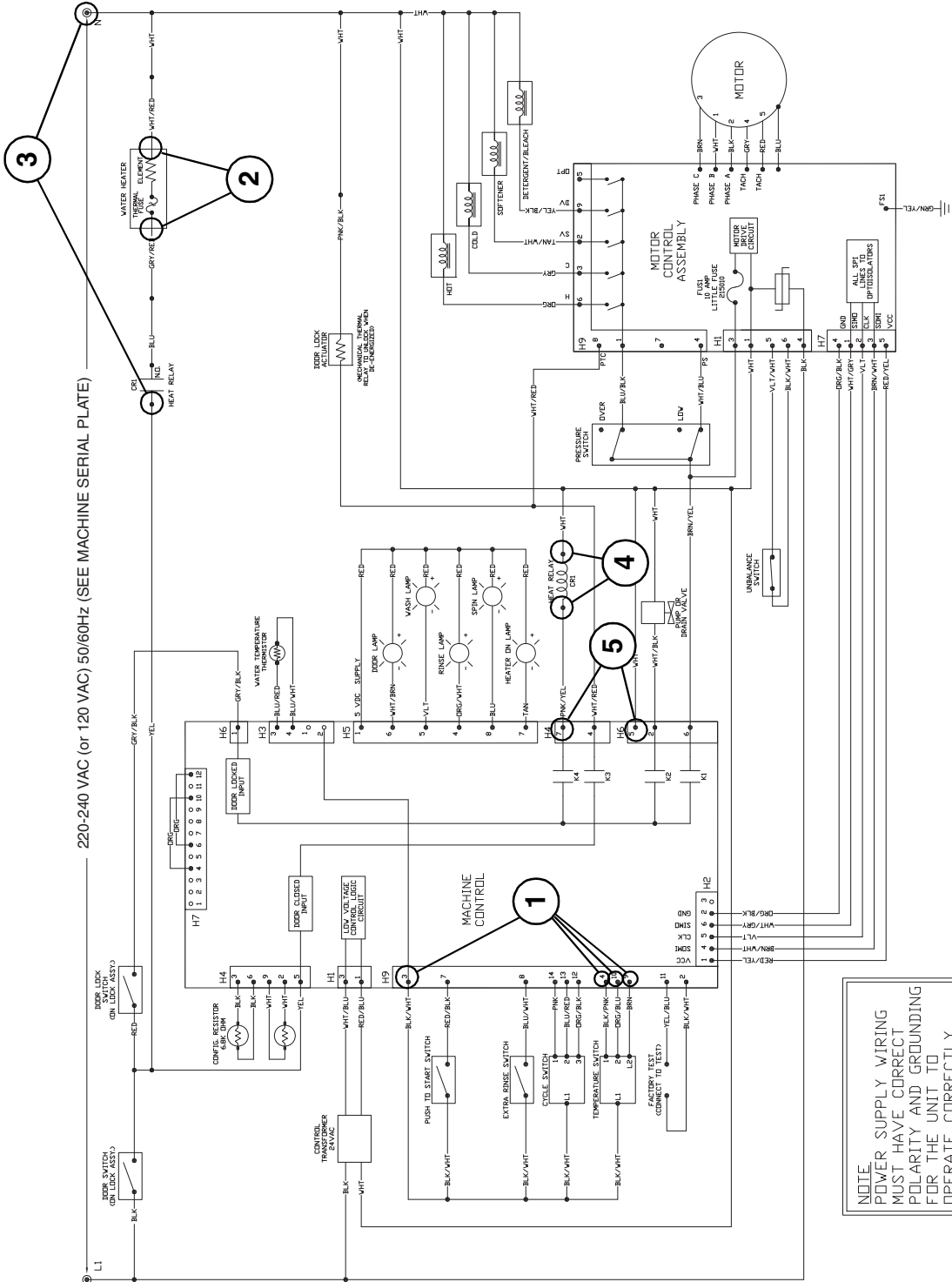

220-240 VAC (or 120 VAC) 50/60Hz (SEE MACHINE SERIAL PLATE)

WATER HEATER	
HEAT	LI-2
HOT	LI-L2-2
COLD	LI-L2-2
WASH	LI-L2-2
RINSE	LI-L2-2
SPIN	LI-L2-2
BLEACH	LI-1

CYCLE SELECT SWITCH	
OFF	LI-1-3
REGULAR	LI-1
PERM. PRESS	LI-L2-2
DELICATE	LI-3
RINSE & SPIN	LI-2
SPIN	LI-2-3

**WARNING**  
Some internal parts are not grounded and may present a risk of electric shock. For safety, always disconnect the power before servicing. **DO NOT** touch the motor or motor control when the machine is plugged in.

**WARNING**  
Failure to install, maintain, or use the unit properly, or failure to follow the instructions may result in fire, electric shock, or property damage.

**NOTE**  
POWER SUPPLY WIRING MUST HAVE CORRECT POLARITY AND GROUNDING FOR THE UNIT TO OPERATE CORRECTLY.



# Section 4 Adjustments



## WARNING

To reduce the risk of electric shock, fire, explosion, serious injury or death:

- Disconnect electric power to the washer before servicing.
- Never start the washer with any guards/panels removed.
- Whenever ground wires are removed during servicing, these ground wires must be reconnected to ensure that the washer is properly grounded.
- Motor not grounded! Disconnect electric power before servicing motor.

W485

**IMPORTANT:** When reference is made to directions (right or left) in this manual, it is from operator's position facing front of washer.

### 18. Cabinet Leveling Legs

- Place washer in position on a solid, sturdy and level floor. Installing the washer on any type of carpeting, soft tile, a platform, or other weakly supported structures is not recommended.
- Place level on washer, refer to *Figure 4*, and check if washer is level from side to side and front to back.

**NOTE:** Level must rest on raised portion of top panel. Refer to *Figure 4*.

- If washer is not level, tilt washer to access front and rear leveling legs. For easier access to leveling legs, prop up washer with wooden block. Refer to *Figure 4*.
- Loosen locknuts and adjust the leveling legs until the washer is level from side to side and front to back (using a level). **Make sure washer does not rock.** Refer to *Figure 4*.

- Tighten the locknuts securely against the washer base. If the locknuts are not tight, washer will move out of position during operation.



## CAUTION

**DO NOT slide washer across floor if the leveling legs have been extended, as legs and base could become damaged.**

W248



## CAUTION

**Use of the dispenser drawer or washer door as a handle in the transportation of the washer may cause damage to the dispenser or door.**

W185

- Place rubber feet on all four leveling legs. Refer to *Figure 4*.
- Verify that washer doesn't rock.
- If unit vibrates or shakes during operation, follow additional leveling procedure below. It is especially effective if unit is installed on uneven, non-concrete surface.
- Loosen one front leveling leg locknut. Refer to *Figure 4*.
- Run cycle with unbalanced load (single pair of blue jeans or knotted towels).
- During 1000 RPM spin, adjust leg up or down by turning it 1/8 turn until washer's vibration is reduced and washer is at its most stable point.
- Re-tighten locknut.



## WARNING

To reduce the risk of electric shock, fire, explosion, serious injury or death:

- Disconnect electric power to the washer before servicing.
- Never start the washer with any guards/panels removed.
- Whenever ground wires are removed during servicing, these ground wires must be reconnected to ensure that the washer is properly grounded.
- Motor not grounded! Disconnect electric power before servicing motor.

W485

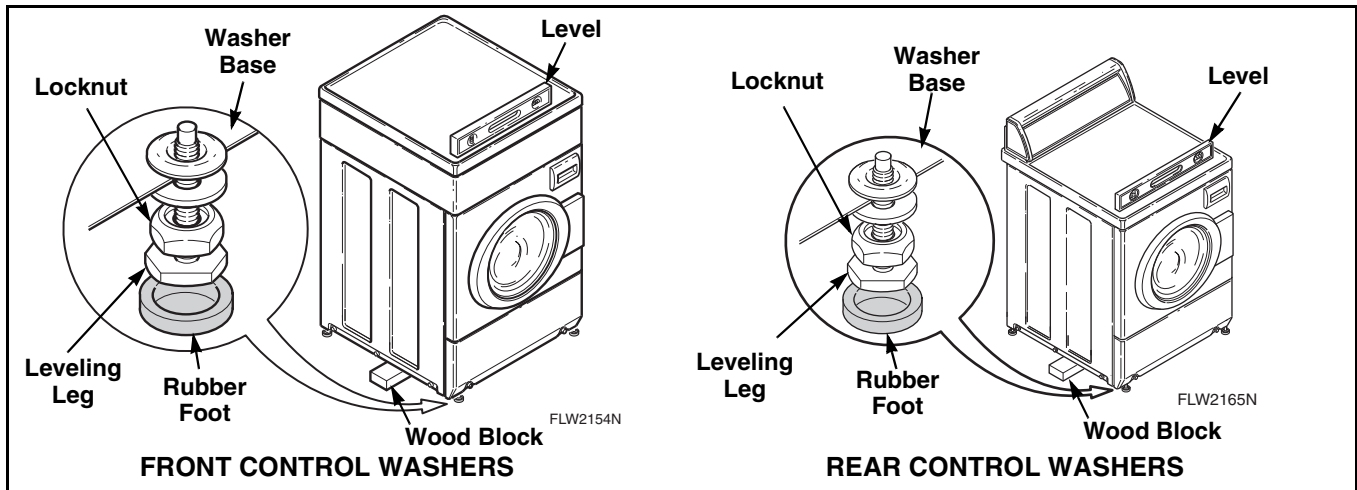

Figure 4

## 19. Loading Door

- Open loading door.
- The loading door can be adjusted up or down somewhat by loosening screws holding door hinge to front panel, then raise or lower door before retightening screws. Refer to *Figure 5*.

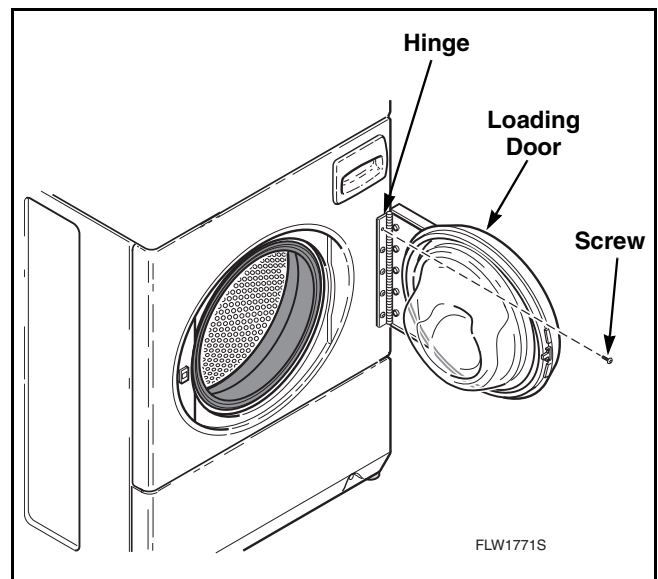

Figure 5





## WARNING

To reduce the risk of electric shock, fire, explosion, serious injury or death:

- Disconnect electric power to the washer before servicing.
- Never start the washer with any guards/panels removed.
- Whenever ground wires are removed during servicing, these ground wires must be reconnected to ensure that the washer is properly grounded.
- Motor not grounded! Disconnect electric power before servicing motor.

W485

## 20. Door Catch

**NOTE:** When repairing a broken or inoperative No. 802803 Door Catch, proceed as follows:

- a. Open loading door.
- b. Remove 11 T-20 Torx head screws holding outer door bezel to inner door bezel. Refer to *Figure 6*.
- c. Pull hinge side of outer bezel away from door and slide forward. Refer to *Figure 6*.
- d. Remove two screws and nuts holding door catch to door and remove door catch.
- e. Install new door catch and tighten screws and nuts to the point of being snug.
- f. Adjust door catch so the outside edge is aligned with the edge of the lock. Refer to *Figure 7*.
- g. Visually check that the door catch properly engages the funnel of the door latch/switch assembly. Refer to *Figure 7*.
- h. Recheck the alignment in step “f”. Adjust if needed.
- i. Torque the two nuts to approximately 20 inch pounds (2.25 Nm).
- j. Reinstall outer door bezel by aligning outer bezel tabs with cut aways on inner bezel and sliding outer bezel into position. Refer to *Figure 6*.
- k. Replace 11 screws holding outer door bezel to inner door bezel.

**IMPORTANT:** Do not overtighten screws or bezel holes will strip.

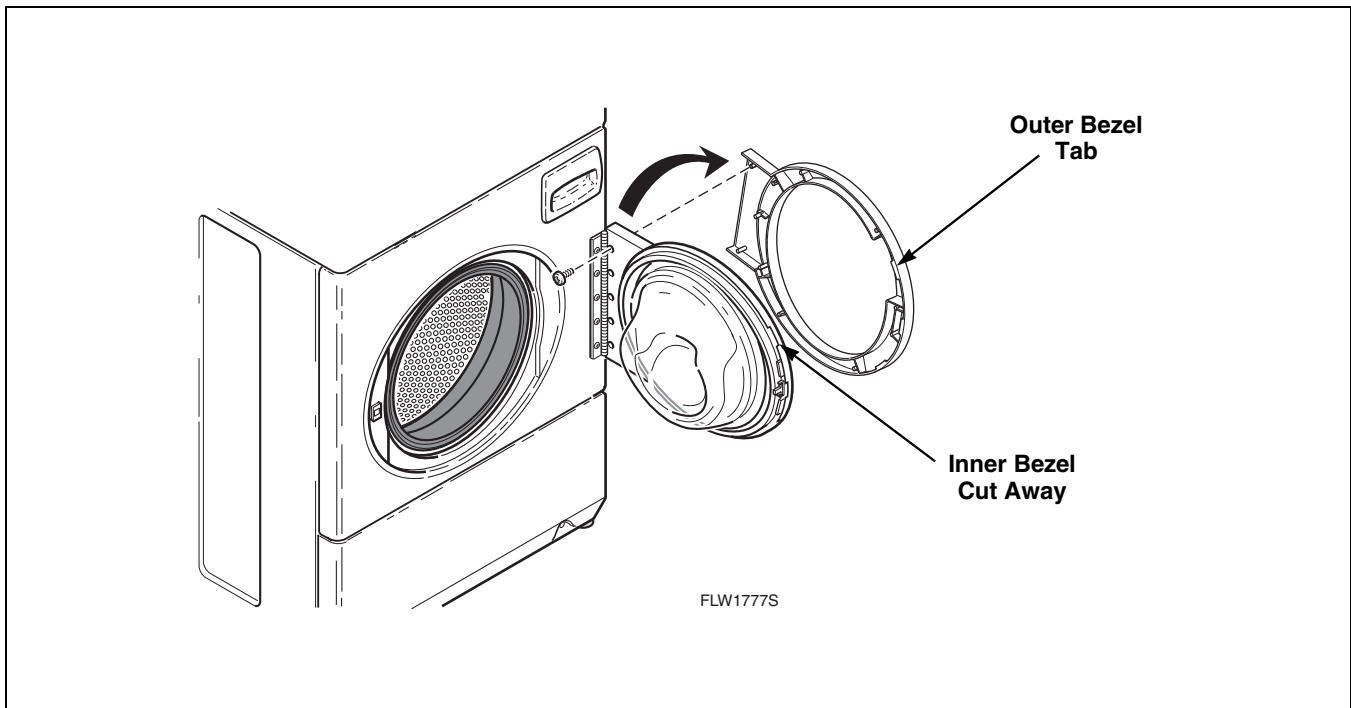

Figure 6



## WARNING

To reduce the risk of electric shock, fire, explosion, serious injury or death:

- Disconnect electric power to the washer before servicing.
- Never start the washer with any guards/panels removed.
- Whenever ground wires are removed during servicing, these ground wires must be reconnected to ensure that the washer is properly grounded.
- Motor not grounded! Disconnect electric power before servicing motor.

W485

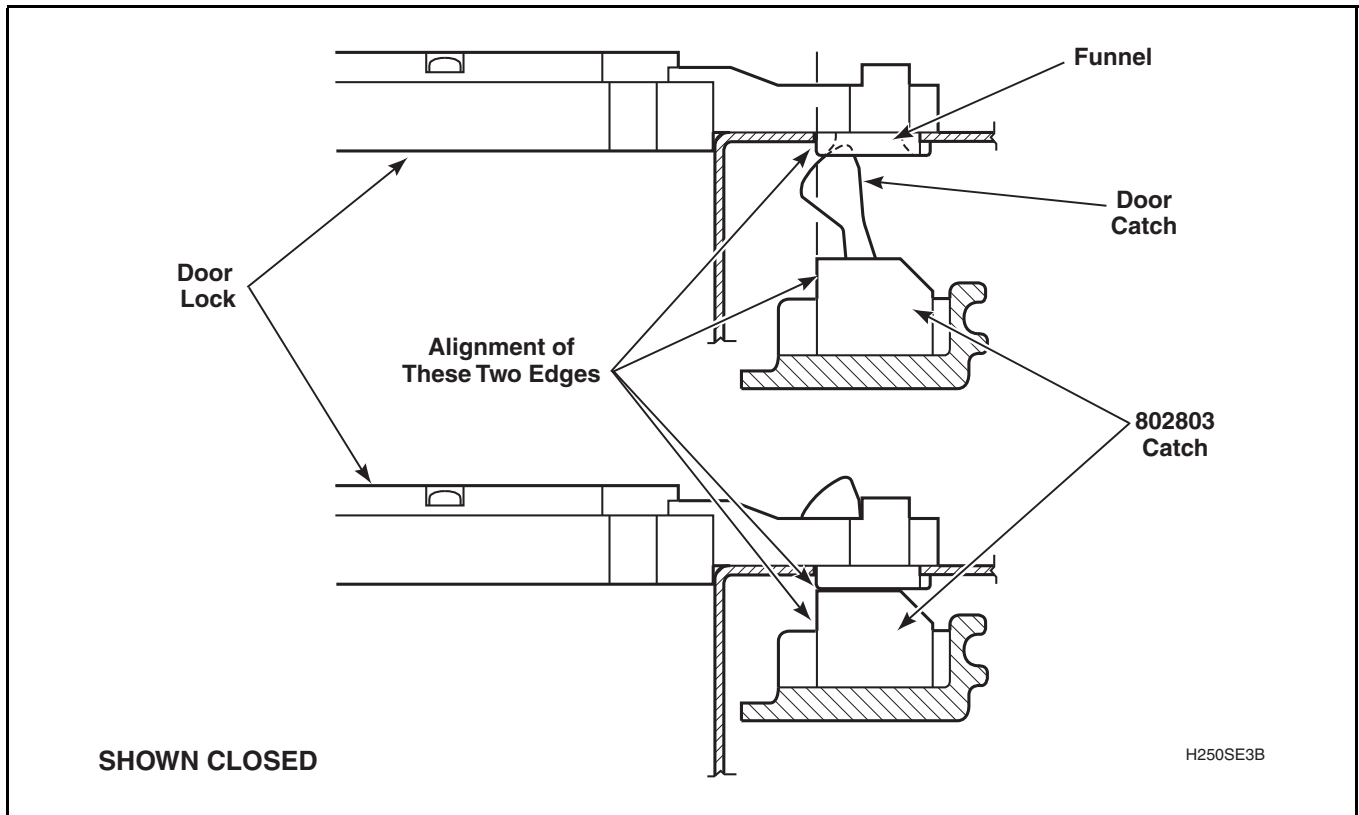

Figure 7



## WARNING

To reduce the risk of electric shock, fire, explosion, serious injury or death:

- Disconnect electric power to the washer before servicing.
- Never start the washer with any guards/panels removed.
- Whenever ground wires are removed during servicing, these ground wires must be reconnected to ensure that the washer is properly grounded.
- Motor not grounded! Disconnect electric power before servicing motor.

W485

## 21. Motor Belt Tension

**NOTE:** Belt adjustment procedures are done through front of washer, however, as an option, washer can be moved from its location and belt adjustment can be done through lower access panel opening at rear of washer.

- While supporting lower front access panel, remove two screws from bottom edge of access panel and remove panel.
- Working through the lower front access door opening, place a locking pliers on the metal rod and loosen the two adjusting bolts. Refer

to *Figure 8*. Repeat procedure to loosen the two pivot bolts. Refer to *Figure 8*.

- Pull down on motor to increase belt tension. Use a Burroughs belt gauge to obtain proper tension. Proper belt tension is obtained when belt can be deflected approximately 1/4 inch (6.35 mm) from normal position when moderate pressure 50 to 60 pounds (22.68 to 27.22 Kg) is applied to a point midway between pulleys. Refer to *Figure 8*.
- After proper belt tension has been obtained, tighten belt adjusting bolts firmly, then tighten pivot bolts. Refer to *Figure 8*.

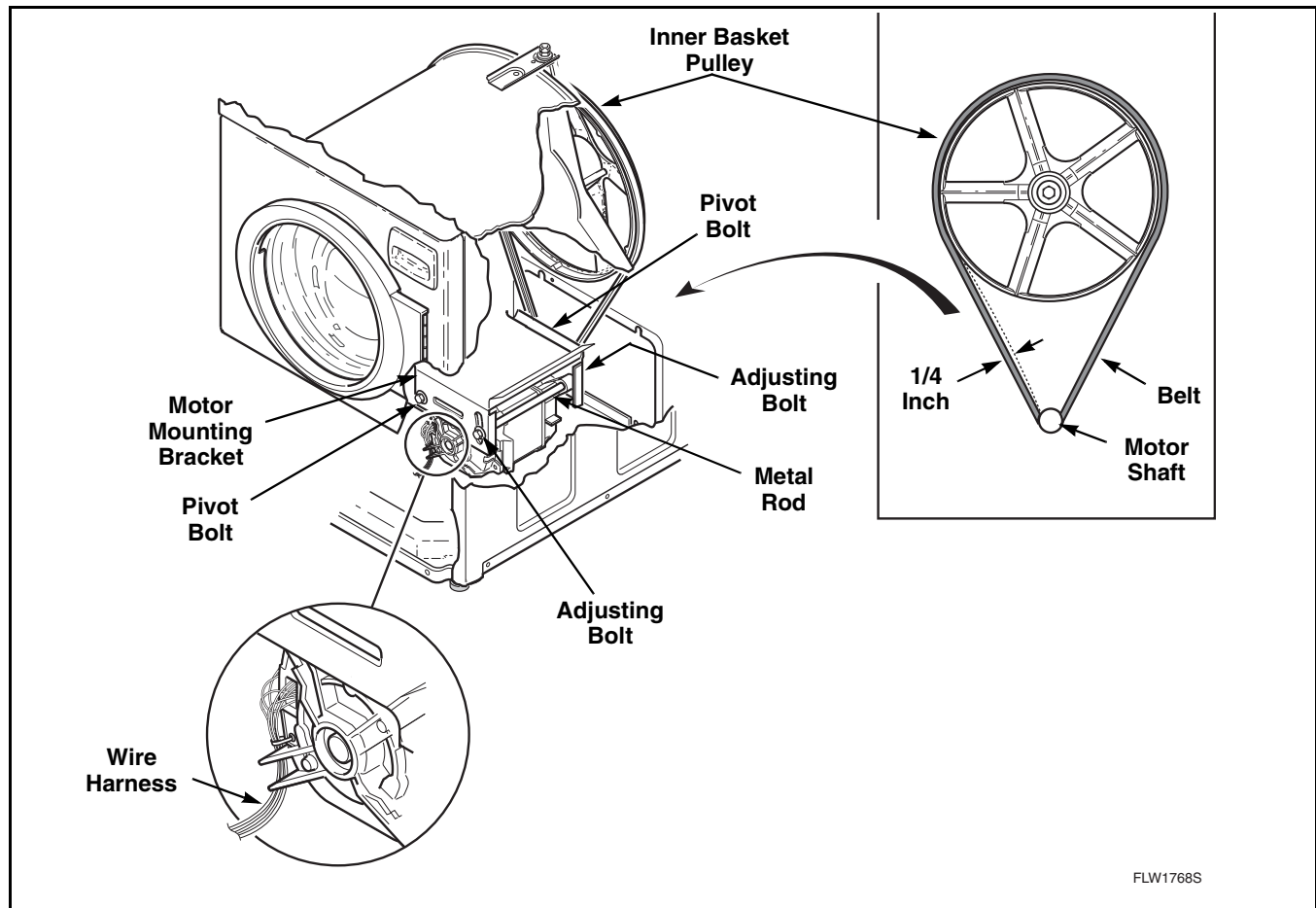

Figure 8



## WARNING

To reduce the risk of electric shock, fire, explosion, serious injury or death:

- Disconnect electric power to the washer before servicing.
- Never start the washer with any guards/panels removed.
- Whenever ground wires are removed during servicing, these ground wires must be reconnected to ensure that the washer is properly grounded.
- Motor not grounded! Disconnect electric power before servicing motor.

W485

## 22. Shipping Braces

All frontload washers, when shipped from the factory are equipped with two factory installed shipping supports. DO NOT remove this shipping material until after washer is placed in its final installed position. Refer to *Figure 9*.

damage to the shock absorbers and will VOID the product warranty.

**NOTE: Shipping supports MUST be kept for future re-positioning or moving of the washer.**

**IMPORTANT: DO NOT tip or move washer once these supports have been removed. Removal of supports prior to final installation may cause**

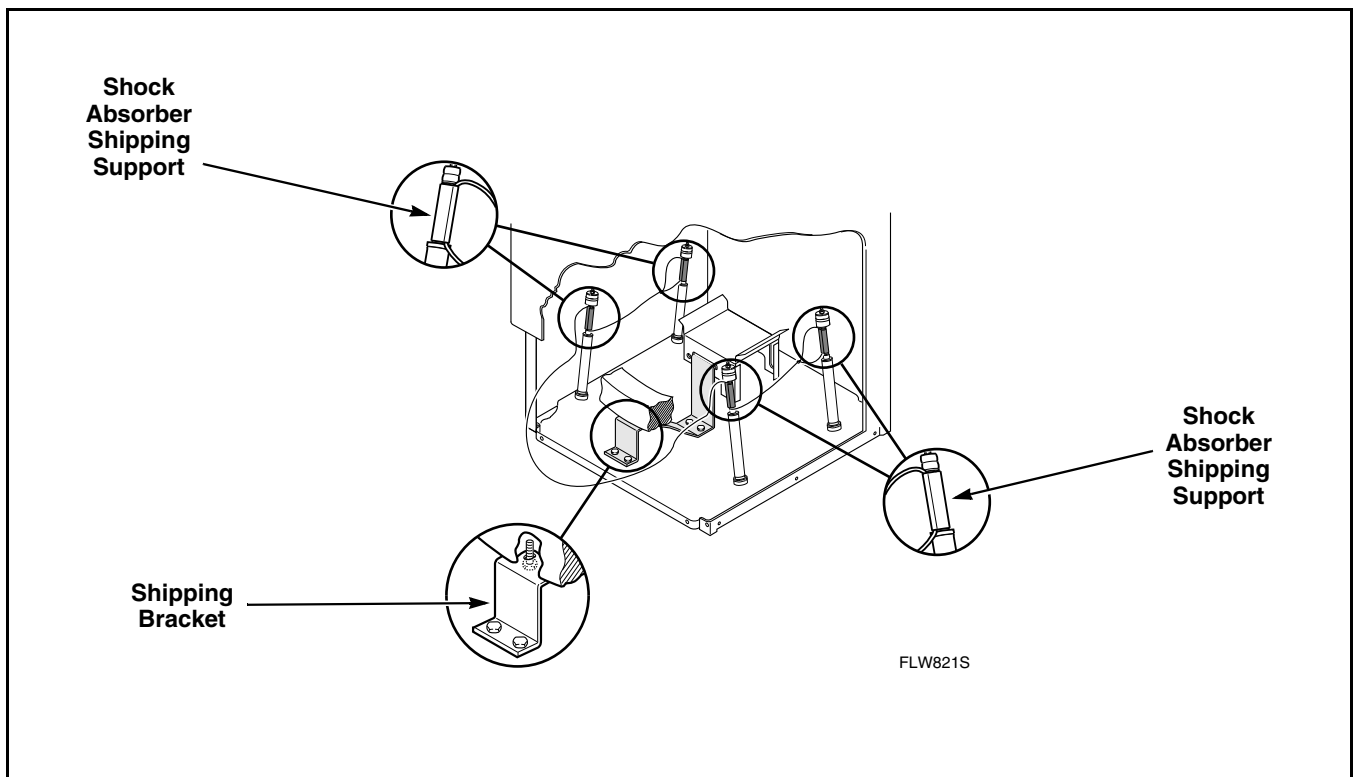

Figure 9