

Drying Tumblers

50 Pound Capacity

75 Pound Capacity

Refer to Page 5 for Model Numbers

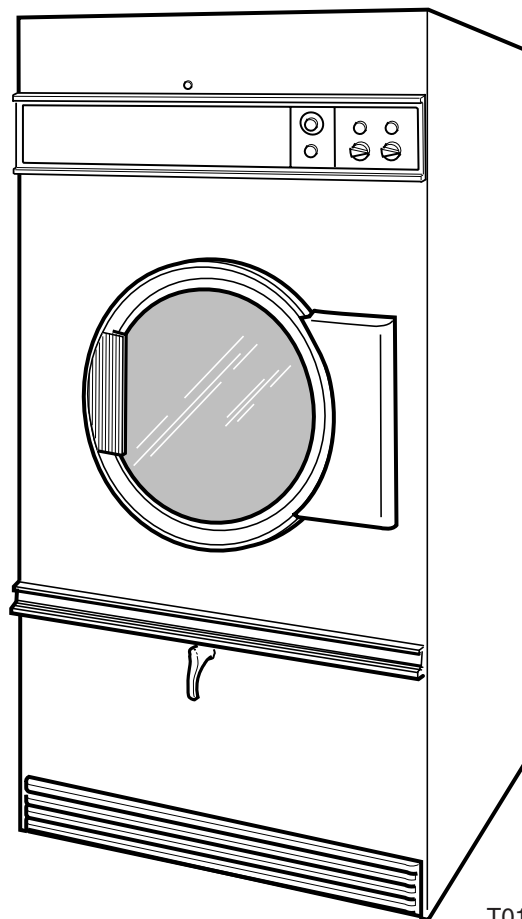

T012c

— Troubleshooting —

Table of Contents

Section 1 – Safety Information	3
Locating An Authorized Service Person	4
Section 2 – Introduction	5
Model Identification	5
Customer Service.....	6
Serial Plate Location.....	6
Safety Warnings and Decals.....	7
Safety Precautions for Servicing Tumblers	7
How A Tumbler Works	8
Section 3 – Troubleshooting.....	10
1. Motor Does Not Start.....	11
2. Motor Overload Protector Cycles Repeatedly	13
3. Motor Runs But Cylinder Does Not Turn.....	14
4. Motor Does Not Stop	15
5. Heating Element Does Not Heat Or Burner Does Not Ignite – Gas and Electric Models	16
6. Pilot Does Not Ignite – Standing Pilot Ignition Gas Models	18
7. Pilot Goes Out – Standing Pilot Ignition Gas Models	19
8. Igniter Does Not Shut Off After Gas Ignition – Automatic Pilot Ignition Gas Models	20
9. Gas Supply Sufficient But Igniter Does Not Glow – Glow-Bar Ignition Gas Models.....	21
10. Igniter Glows, Sensor Opens But No Ignition – Johnson Controls System Gas Models.....	22
11. Igniter Glows, Sensor Opens But No Ignition – White Rodgers Glow-Bar Ignition Gas Models.....	23
12. Burner Ignites and Goes Out Repeatedly – Glow-Bar Ignition Gas Models.....	24
13. Heating Element or Burner Shuts-Off Prematurely	25
14. Heating Element or Burner Repeatedly Cycles Off On High Limit Thermostat.....	26
15. Heating Element or Burner Does Not Shut-Off.....	27
16. Clothes Do Not Dry	28
17. Tumbler Overheating	29
18. Burners Not Burning Properly – Gas Models	30
19. Loading Door Opens During Operation.....	31
20. Tumbler Runs But No Steam To Coils – Steam Models	32
21. Water In Steam Line – Steam Models	33
22. Troubleshooting Electronic Control Models.....	34
23. Tumbler Will Not Start, Time on Drying Timer, Door Closed – Manual Timer Models	36
24. Motor Runs, Time on Drying Timer But No Heat.....	37
25. No Spark to Pilot Burner – Electronic Pilot Ignition Models	39
26. Spark to Pilot Burner, No Pilot Flame – Electronic Pilot Ignition Models	40
27. Spark To Pilot Burner, Pilot Lights, No Main Burner – Electronic Pilot Ignition Models	41

© Copyright 2007, Alliance Laundry Systems LLC

All rights reserved. No part of the contents of this book may be reproduced or transmitted in any form or by any means without the expressed written consent of the publisher.

28. Igniter Does Not Glow – Johnson Controls Glow-Bar System.....	42
29. Igniter Glows Constantly – Johnson Controls and White Rodgers Glow-Bar System.....	43
30. Igniter Glows, Cycles Off But Burner Does Not Ignite – Johnson Controls Glow-Bar System.....	44
31. Igniter Does Not Glow – White Rodgers Glow-Bar System.....	45
32. Igniter Glows, Cycles Off But Burner Does Not Ignite – White Rodgers Glow-Bar System.....	46
33. Igniter Sparks, No Main Burner Ignition – Instant Electronic Ignition.....	47
34. CSH OM Models: No Heat With Cycle Selected, Unit Running and Calling For Heat.....	48
35. OM Models: No Start With Cycle Selected, Start Button Pressed and Door Closed.....	50
36. OM Models: No Display After Selecting One Of The ON/SELECT Keys.....	52
37. CE OM Models: No Heat With Cycle Selected, Unit Running and Calling For Heat.....	53
38. CG OM Models: No Heat With Cycle Selected, Unit Running and Calling For Heat.....	55
39. OM Models: No Fan Motor Rotation With Cycle Selected and Start Pressed.....	57
40. MM Models: Fan Motor Does Not Run With Door Closed, Cycle Selected and Start Button Pressed.....	58
41. MM Models: Cylinder Motor Does Not Run or Reverse With Door Closed, Cycle Selected and Start Button Pressed In Reversing Mode or Nonreversing Mode.....	59
42. MM Models: No Heat With Cycle Selected, Unit Running and Calling For Heat.....	61
43. MM Models: No Heat With Cycle Selected, Unit Running and Calling For Heat.....	63
44. OM Reversing Models: No Cylinder Rotation or Reversing Capabilities.....	65
45. MM Models: No Display After Pressing the ON/SELECT Keys.....	67
46. MM Models: Motor Does Not Run With Door Closed, Cycle Selected and Start Button Pressed.....	68
47. MM Models: Cylinder Motor Does Not Run or Reverse With Door Closed, Cycle Selected and Start Button Pressed In Reversing Mode or Nonreversing Mode.....	69
48. MM Nonreversing Models: Motor Does Not Run With Door Closed, Cycle Selected and Start Button Pressed.....	71
49. CD Models: No Start With Vend Satisfied and Start Button Pushed.....	73
50. CD Models: No Heat With Vend Satisfied and Unit Running ...	75
51. CD Models: No Heat With Vend Satisfied and Unit Running ...	77
52. CD Models: No Start With Vend Satisfied and Start Button Pushed.....	79
53. CD Models: No Start With Vend Satisfied and Start Button Pushed.....	81
Section 4 – Adjustments.....	82
54. Cylinder Clearance.....	82

Section 1

Safety Information

Throughout this manual and on machine decals, you will find precautionary statements (“CAUTION”, “WARNING”, and “DANGER”) followed by specific instructions. These precautions are intended for the personal safety of the operator, user, servicer, and those maintaining the machine.

	DANGER
<p>DANGER indicates the presence of a hazard that will cause severe personal injury, death, or substantial property damage if the danger is ignored.</p>	

	WARNING
<p>WARNING indicates the presence of a hazard that can cause severe personal injury, death, or substantial property damage if the warning is ignored.</p>	

	CAUTION
<p>CAUTION indicates the presence of a hazard that will or can cause minor personal injury or property damage if the caution is ignored.</p>	

Additional precautionary statements (“IMPORTANT” and “NOTE”) are followed by specific instructions.

IMPORTANT: The word “IMPORTANT” is used to inform the reader of specific procedures where minor machine damage will occur if the procedure is not followed.

NOTE: The word “NOTE” is used to communicate installation, operation, maintenance or servicing information that is important but not hazard related.

In the interest of safety, some general precautions relating to the operation of this machine follow.

	WARNING
<ul style="list-style-type: none">• Failure to install, maintain and/or operate this product according to the manufacturer’s instructions may result in conditions which can produce serious injury, death and/or property damage.• Do not repair or replace any part of the product or attempt any servicing unless specifically recommended or published in this Service Manual and unless you understand and have the skills to carry out the servicing.• Whenever ground wires are removed during servicing, these ground wires must be reconnected to ensure that the product is properly grounded and to reduce the risk of fire, electric shock, serious injury or death.	
<p>W006R2</p>	

Safety Information

IMPORTANT INFORMATION: During the lifetime of a tumbler, it may require service. The information contained in this manual was written and is intended for use by qualified service technicians who are familiar with the safety procedures required in the repair of a tumbler, and who are equipped with the proper tools and testing equipment.

	WARNING
<p>To reduce the risk of electric shock, fire, explosion, serious injury or death:</p> <ul style="list-style-type: none">• Disconnect electric power to the tumbler before servicing.• Never start the tumbler with any guards/panels removed.• Whenever ground wires are removed during servicing, these ground wires must be reconnected to ensure that the tumbler is properly grounded.	
<small>W240</small>	

	WARNING
<p>Repairs that are made to your products by unqualified persons can result in hazards due to improper assembly or adjustments subjecting you or the inexperienced person making such repairs to the risk of serious injury, electrical shock or death.</p>	
<small>W007</small>	

	CAUTION
<p>If you or an unqualified person perform service on your product, you must assume the responsibility for any personal injury or property damage which may result. The manufacturer will not be responsible for any injury or property damage arising from improper service and/or service procedures.</p>	
<small>W008</small>	

NOTE: The **WARNING** and **IMPORTANT** instructions appearing in this manual are not meant to cover all possible conditions and situations that may occur. It must be understood that common sense, caution and carefulness are factors which **CANNOT** be built into this tumbler. These factors **MUST BE** supplied by the person(s) installing, maintaining or operating the tumbler.

Always contact your dealer, distributor, service agent or the manufacturer on any problems or conditions you do not understand.

Locating An Authorized Service Person

Alliance Laundry Systems is not responsible for personal injury or property damage resulting from improper service. Review all service information before beginning repairs.

Warranty service must be performed by an authorized technician, using authorized factory parts. If service is required after the warranty expires, Alliance Laundry Systems also recommends contacting an authorized technician and using authorized factory parts.

Section 2 Introduction

Model Identification

Information in this manual is applicable to these models:

	Gas		Steam/Thermal Oil		Electric
50 Pound	ATB50CG	JT50EGI	ATB50CSH	JTB50CSH	DCB50CE
	DCB50CG	JTB50CG	DCB50CSH	JTB50CSL	DTB50CE
	DCB50EG	JTB50EG	DTB50CSH	SC50CSH	JC50CE
	DTB50CG	SC50CG	DTB50CSL	SCB50AT	JCB50CE
	DTB50EG	SC50EG	JC50CSH	SCB50CSH	JT37CE
	JC50CG	SCB50CG	JCB50CSH	ST37CSH	JT50CE
	JC50EG	SCB50EG	JT37CSH	ST37CSL	JTB50CE
	JCB50CG	ST37CG	JT37CSL	ST50CSH	SC50CE
	JCB50EG	ST37CGI	JT50CSH	ST50CSL	SCB50CE
	JT37CG	ST37EG	JT50CSL	STB50CSH	ST37CE
	JT37CGI	ST37EGI		STB50CSL	ST50CE
	JT37EG	ST50CGI			STB50CE
	JT37EGI	ST50EGI			TKD50CEMT
	JT50CG	STB50CG			
	JT50CGI	STB50EG			
JT50EG	TKD50CGMT				
75 Pound	ATB75CG	JT75CG	ATB75CSH	JTB75CSH	DCB75CE
	DCB75CG	JT75EG	DCB75CSH	JTB75CSL	DTB75CE
	DCB75FG	JTB75CG	DCB75CSL	SCB75CSH	JCB75CE
	DTB634	JTB75EG	DTB75CSH	SCB75CSL	JT75CE
	DTB75CG	SCB75CG	DTB75CSL	ST75CSH	JTB75CE
	DTB75EG	ST75CG	JCB75CSH	ST75CSL	SCB75CE
	DTB75FG	STB634	JCB75CSL	STB75CSH	ST75CE
	JCB75CG	STB75CG	JT75CSH	STB75CSL	STB75CE
		STB75EG	JT75CSL		

Introduction

Customer Service

If literature or replacement parts are required, contact the source from whom the machine was purchased or contact Alliance Laundry Systems at (920) 748-3950 for the name and address of the nearest authorized parts distributor.

For technical assistance, call (920) 748-3121.

Serial Plate Location

When calling or writing about your product, be sure to mention model and serial numbers. Model and serial numbers are located on serial plate(s) as shown.

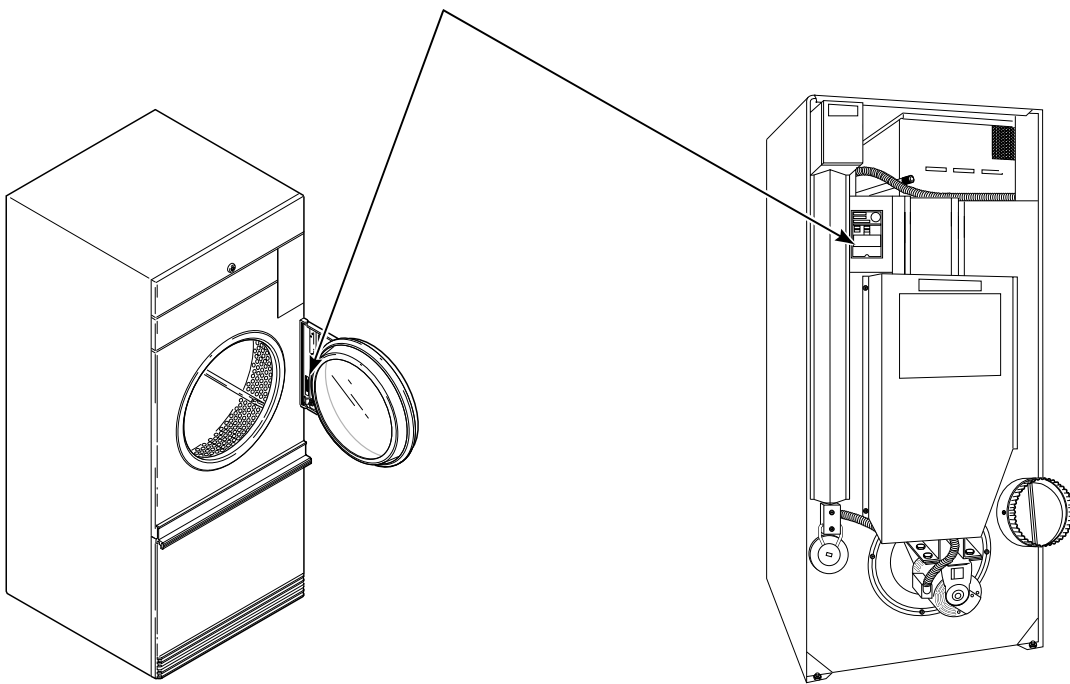

T419IE3B

Safety Warnings and Decals

SAFETY WARNINGS and decals have been provided in key locations to remind you of important precautions for the safe operation and maintenance of your tumbler. Please take the time to review these warnings before proceeding with service work.

All decals have been designed and applied to withstand washing and cleaning. Decals should be checked periodically to be sure they have not been damaged, removed, or painted. Refer to *Parts Manual* for ordering replacement decals.

Safety Precautions for Servicing Tumblers

- **Disconnect electrical service.**
- **Shut off supply gas valve before servicing gas components.**
- **Control panel and access panel MUST be reinstalled after inspection or servicing of tumbler is completed.**
- **Use a non-corrosive leak detection fluid to check all pipe connections for gas leaks. DO NOT USE AN OPEN FLAME TO CHECK FOR GAS LEAKS!**
- **Chain/drive guard MUST be reinstalled after inspection or servicing of tumbler is completed.**
- **Belt guard MUST be reinstalled after inspection or servicing of tumbler is completed.**
- **Contactors box cover MUST be reinstalled after inspection or servicing of electric and/or reversing tumbler is completed.**
- **Loading door switch MUST be operational before putting tumbler into service.**
- **Junction box cover MUST be reinstalled after inspection or servicing of tumbler is completed.**

How A Tumbler Works

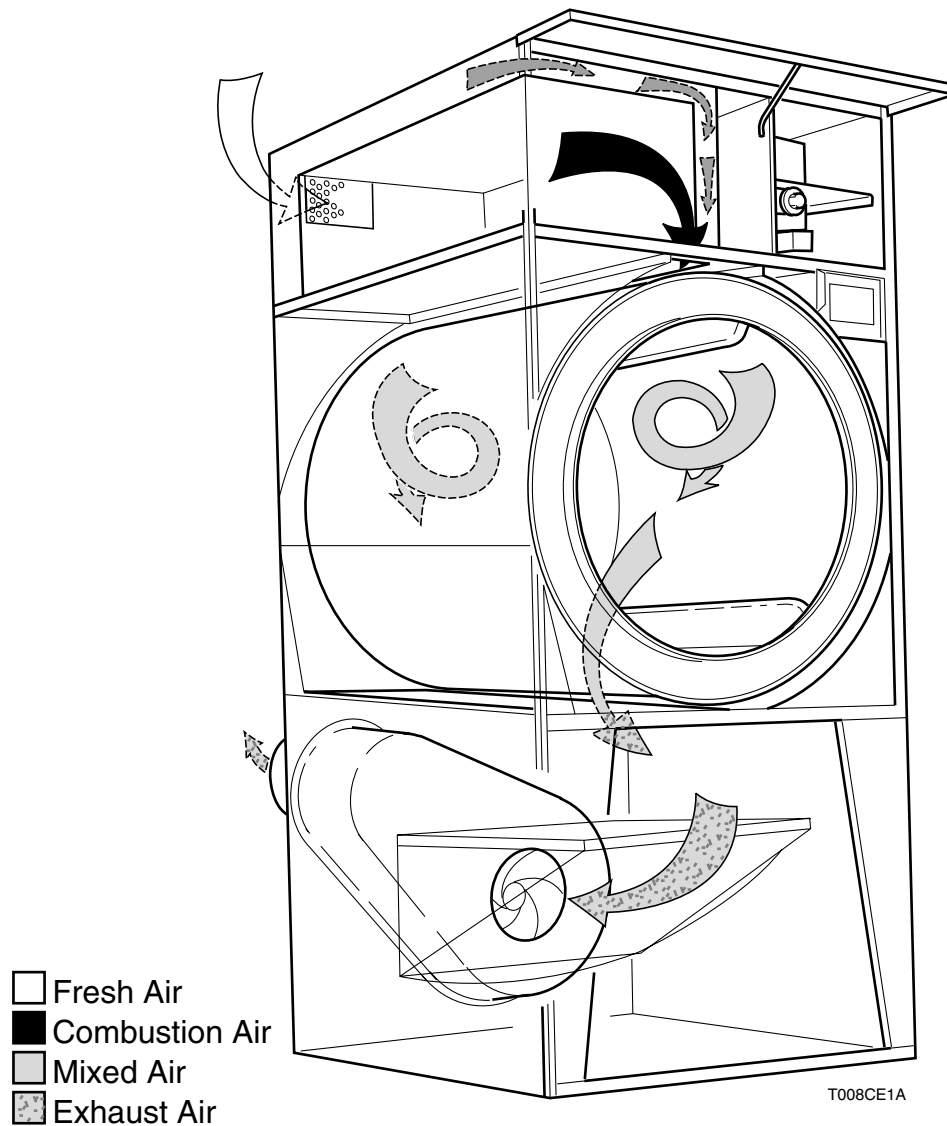

Standard Models

The tumbler uses heat, air and movement to dry loads of laundry.

When the motor is started, the exhaust fan pulls fresh air in through the air intake and over the heat source (burner flame for gas, heating element for electric, and coil for steam).

The heated air moves into the cylinder, where it is circulated through the laundry by the tumbling action of the cylinder.

The air then passes through the lint filter, exhaust fan, and is vented to the outdoors.

NOTE: In Energy Saver Models, some of the exhaust air is recirculated. Refer to illustration on next page.

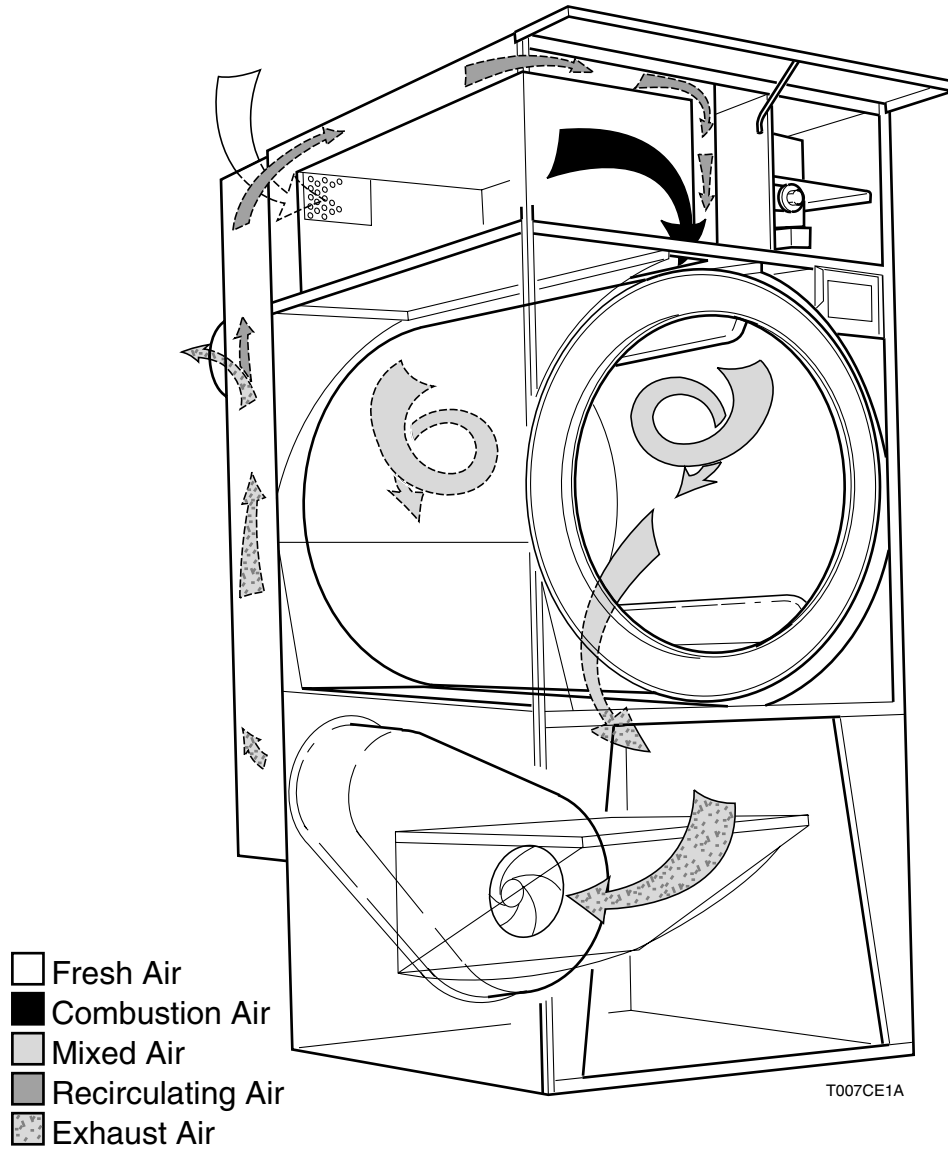

Energy Saver Models

Section 3

Troubleshooting



WARNING

To reduce the risk of electric shock, fire, explosion, serious injury or death:

- Disconnect electric power to the tumbler before servicing.
- Close gas shut-off valve to gas tumbler before servicing.
- Close steam valve to steam tumbler before servicing.
- Never start the tumbler with any guards/panels removed.
- Whenever ground wires are removed during servicing, these ground wires must be reconnected to ensure that the tumbler is properly grounded.

W002

IMPORTANT: Refer to wiring diagram for aid in testing tumbler components.

1. Motor Does Not Start

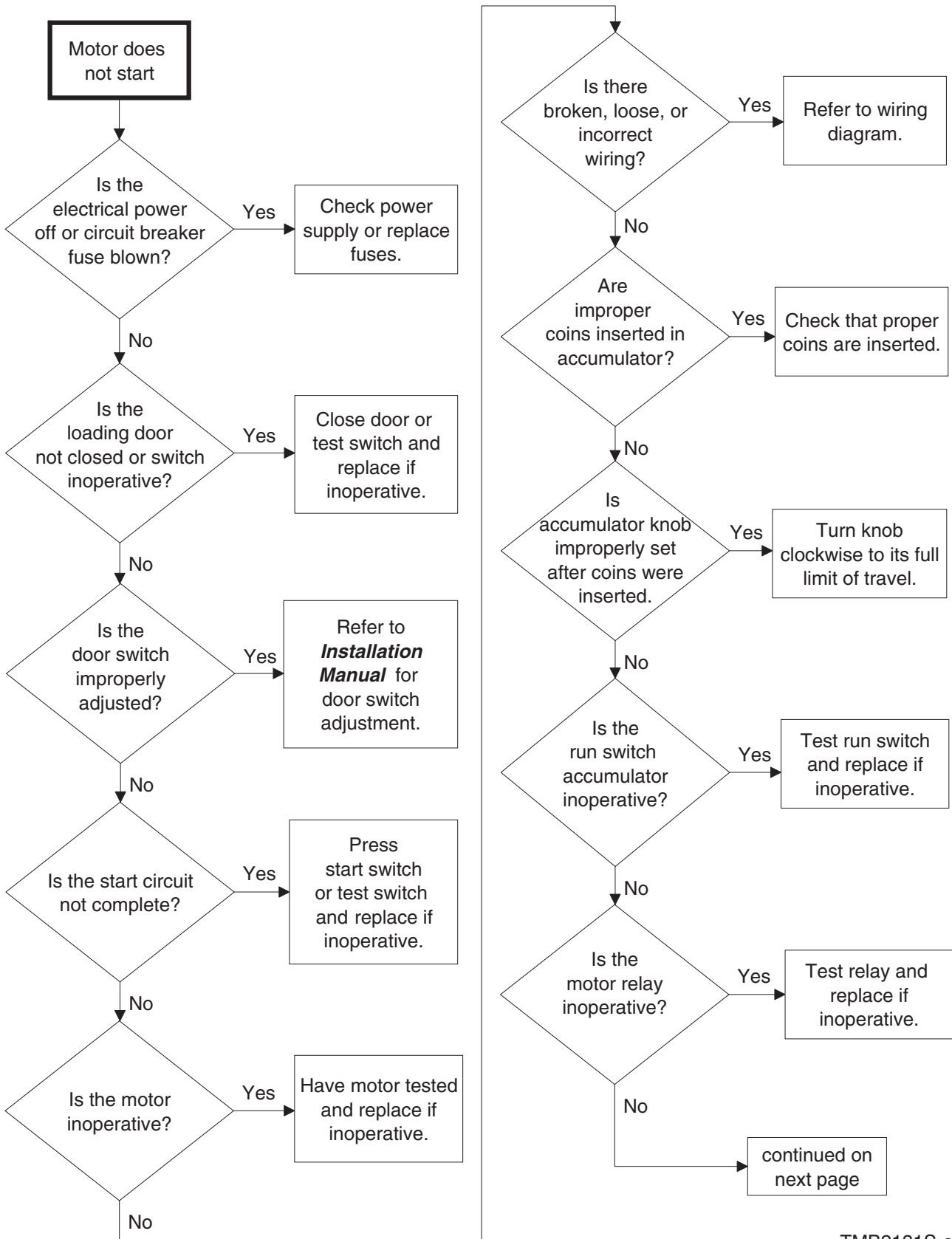

TMB2131S-a

1. Motor Does Not Start (continued)

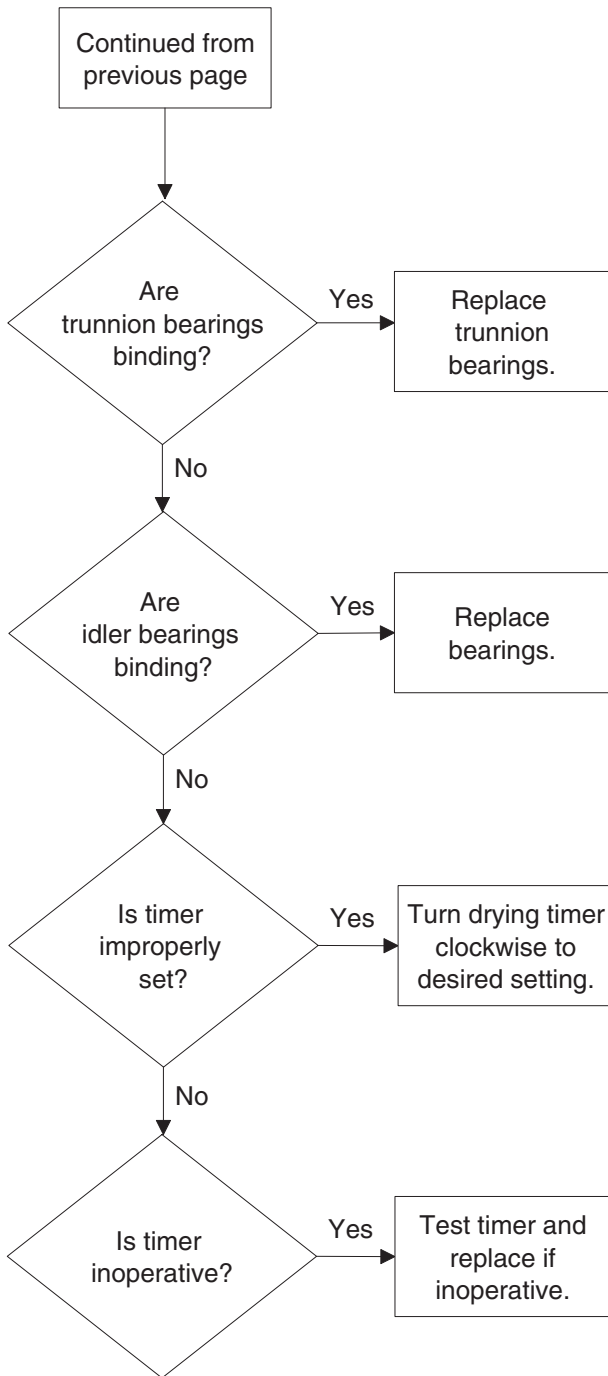

2. Motor Overload Protector Cycles Repeatedly

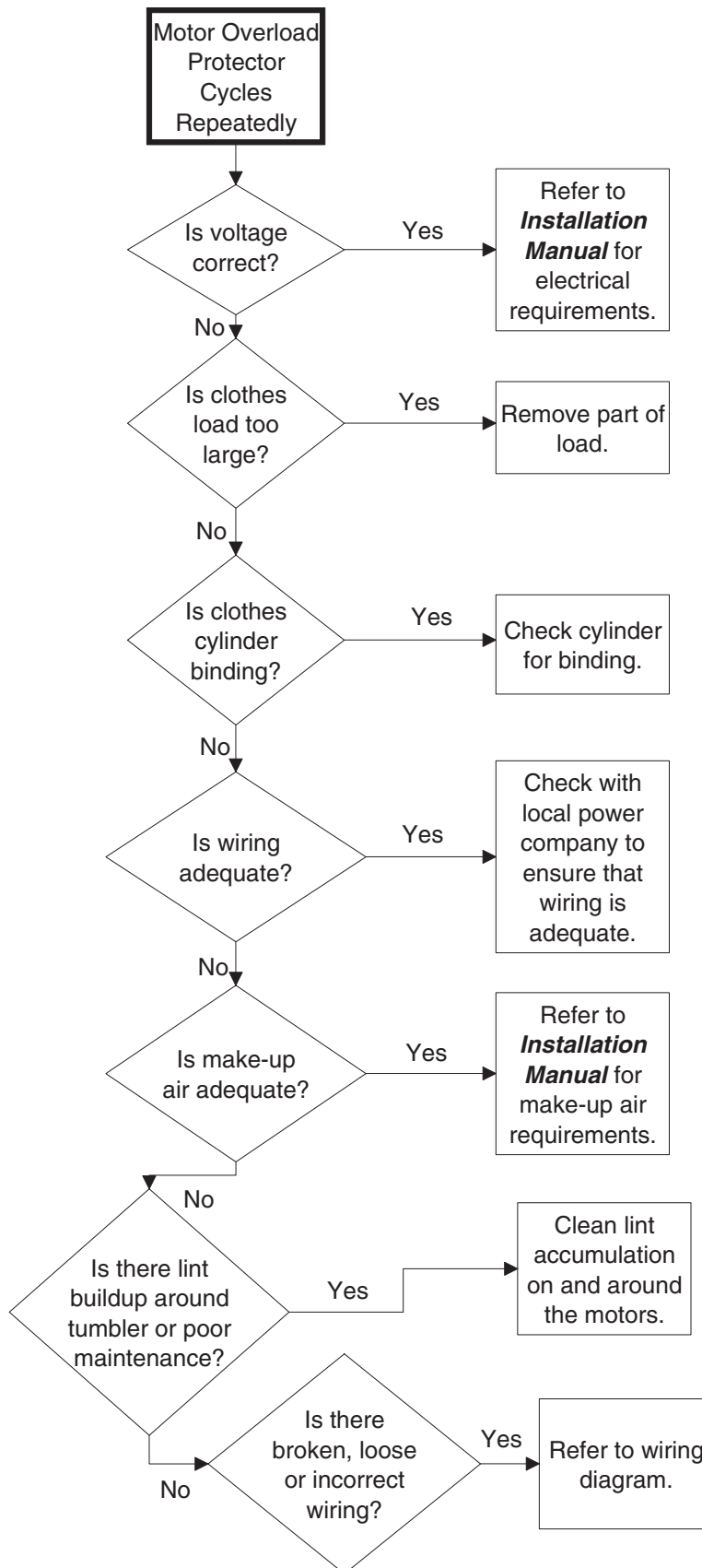

TMB1904S

3. Motor Runs But Cylinder Does Not Turn

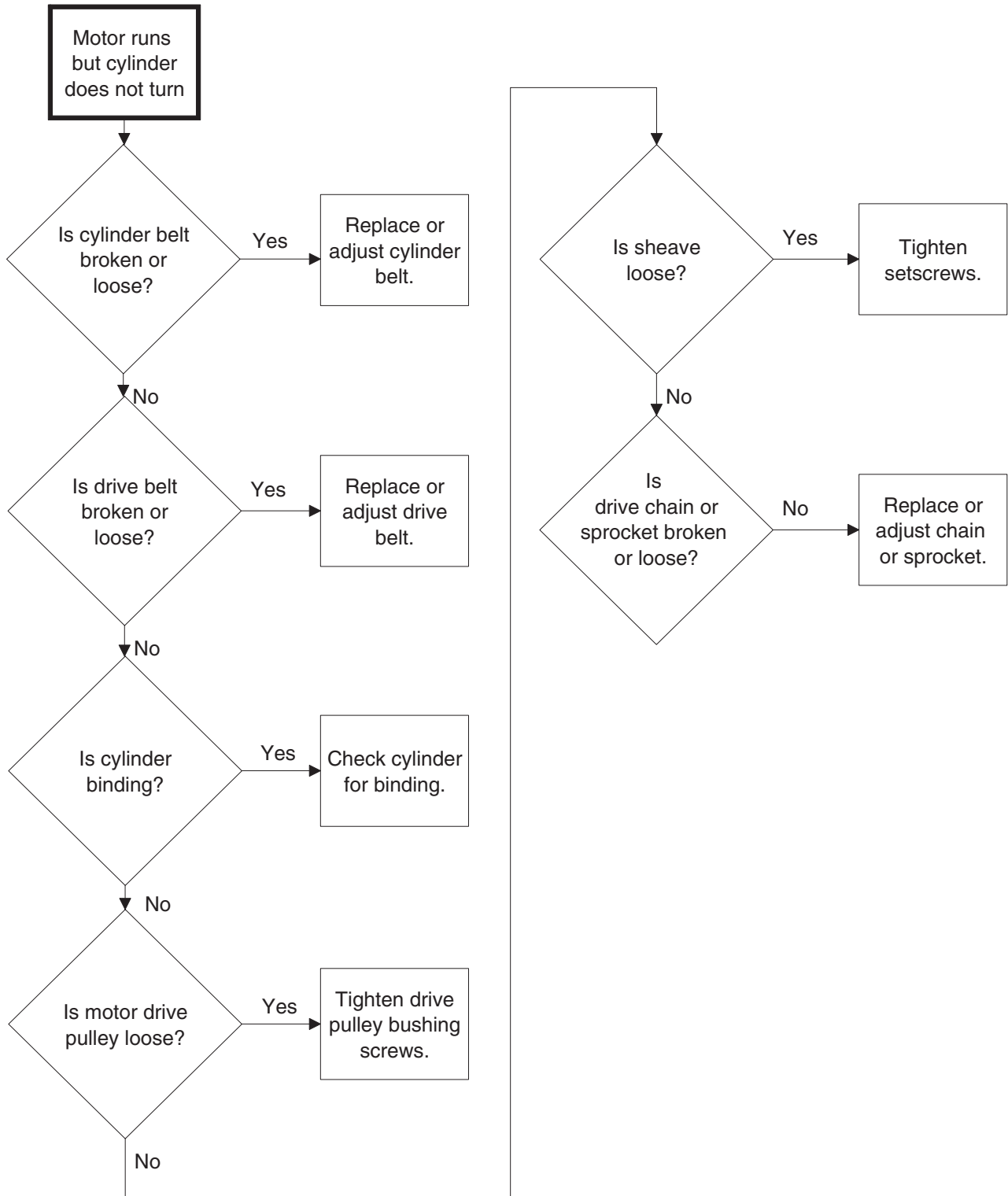

TMB2132S

4. Motor Does Not Stop

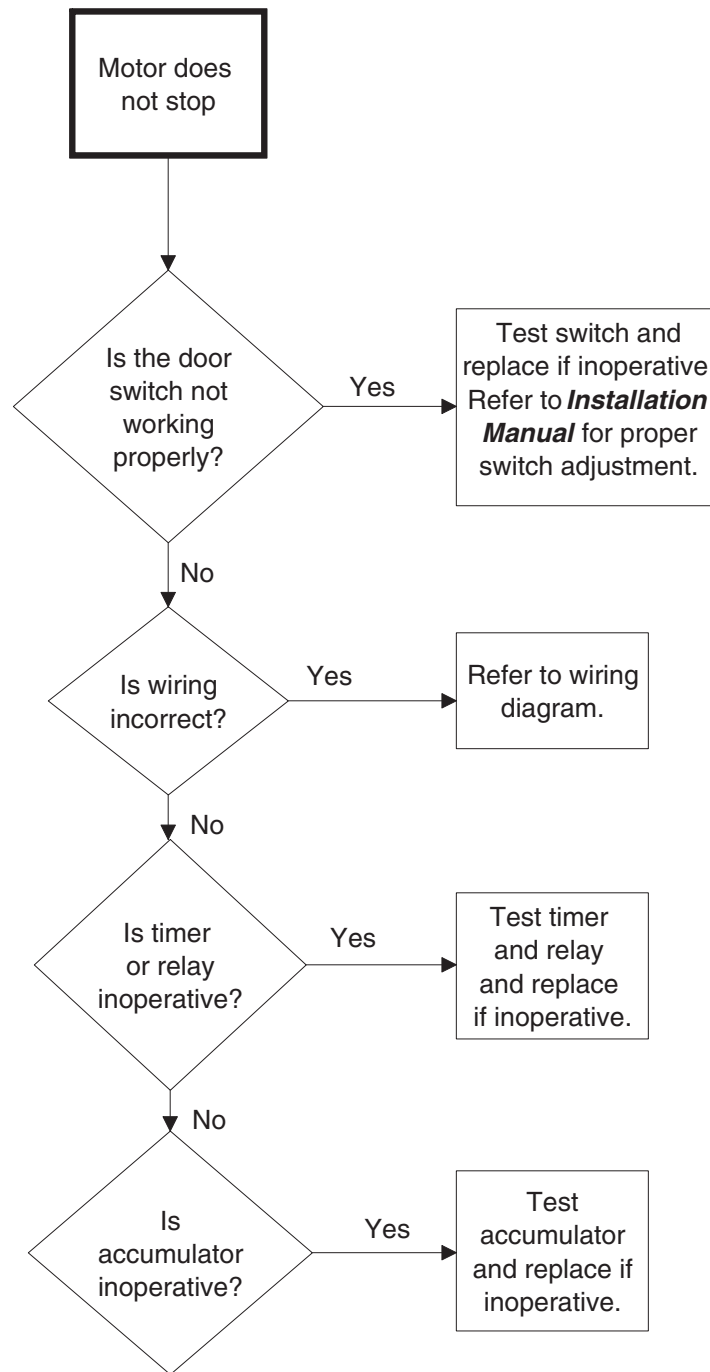

TMB2133S

5. Heating Element Does Not Heat Or Burner Does Not Ignite – Gas and Electric Models

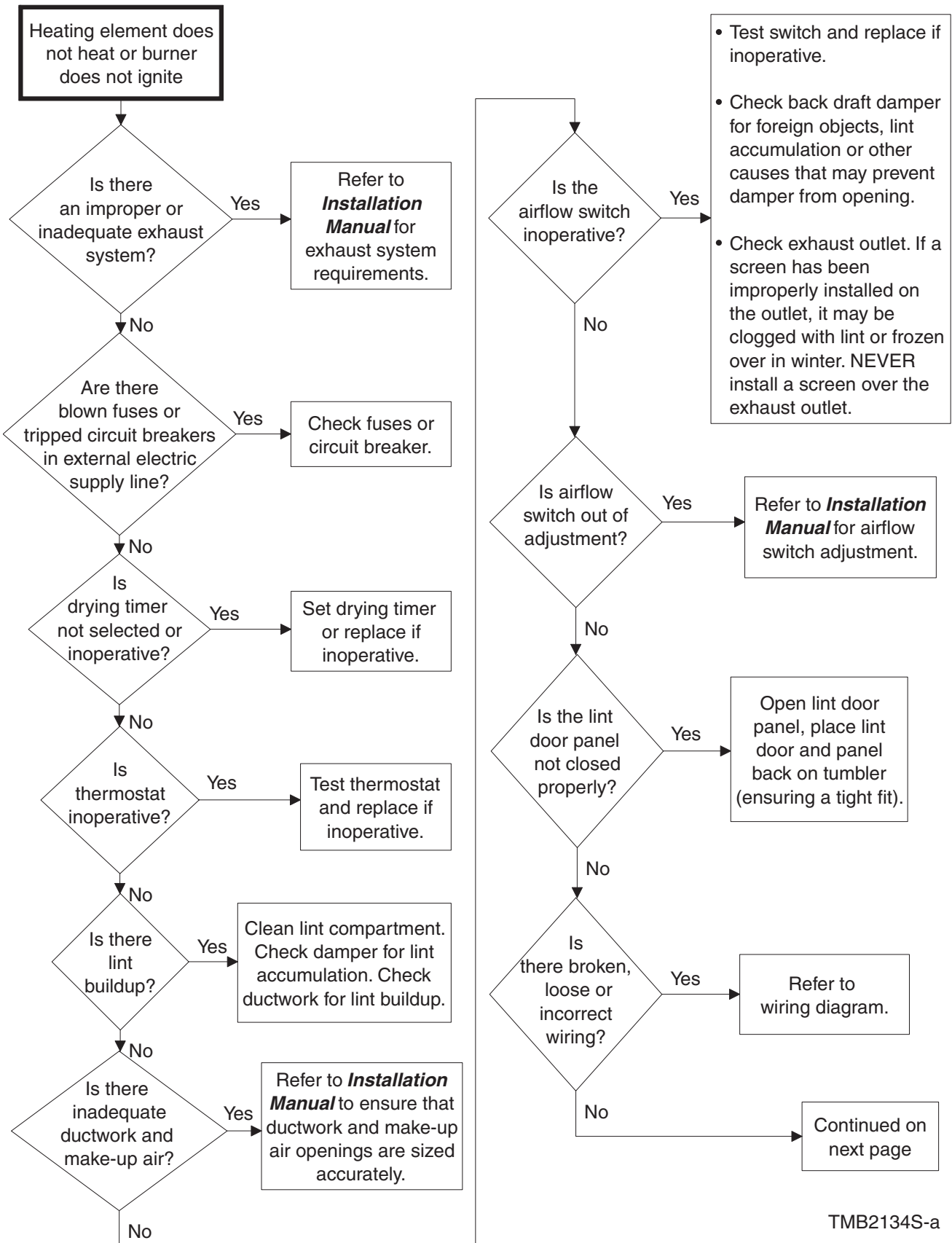

TMB2134S-a

5. Heating Element Does Not Heat Or Burner Does Not Ignite – Gas and Electric Models (continued)

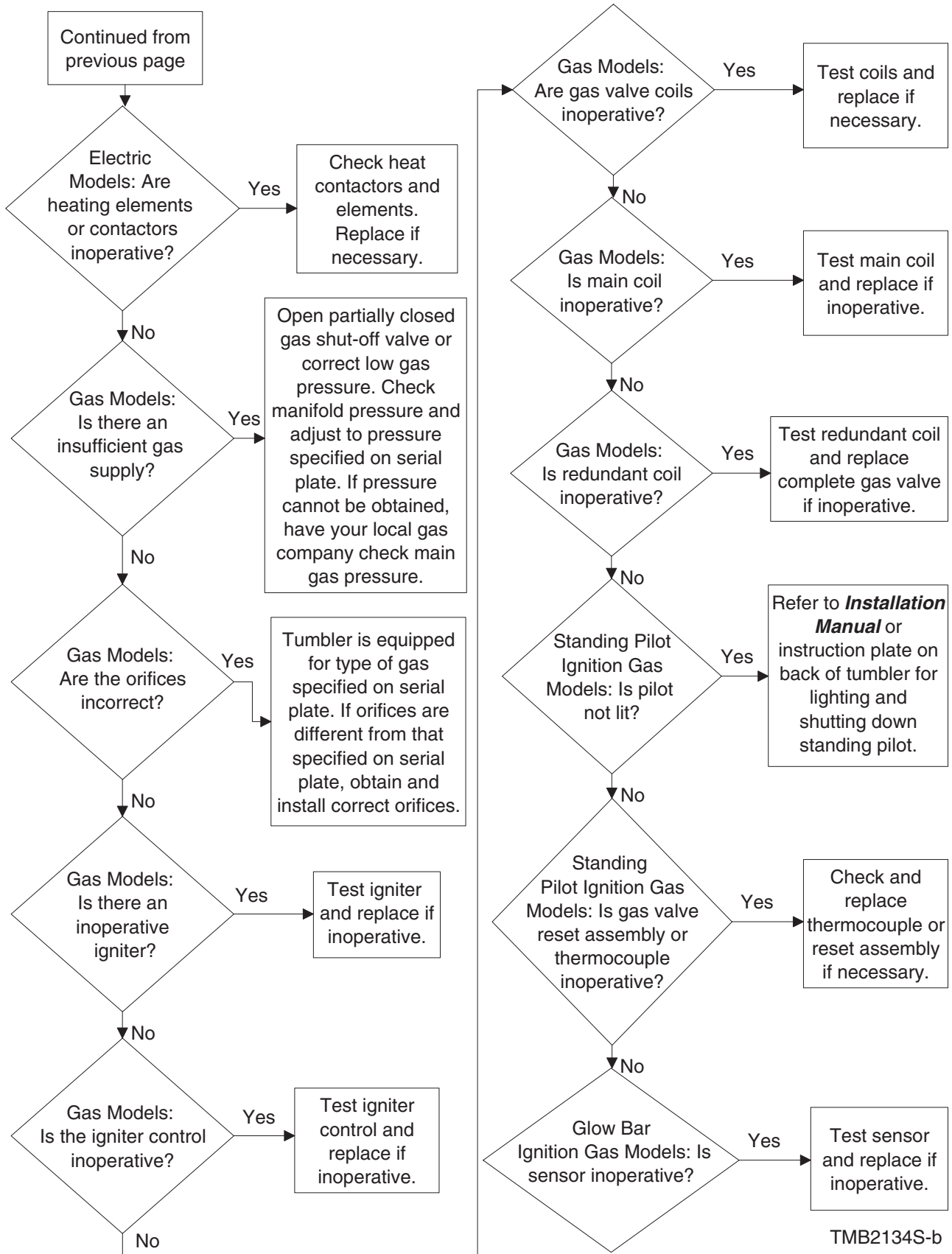

TMB2134S-b

6. Pilot Does Not Ignite – Standing Pilot Ignition Gas Models

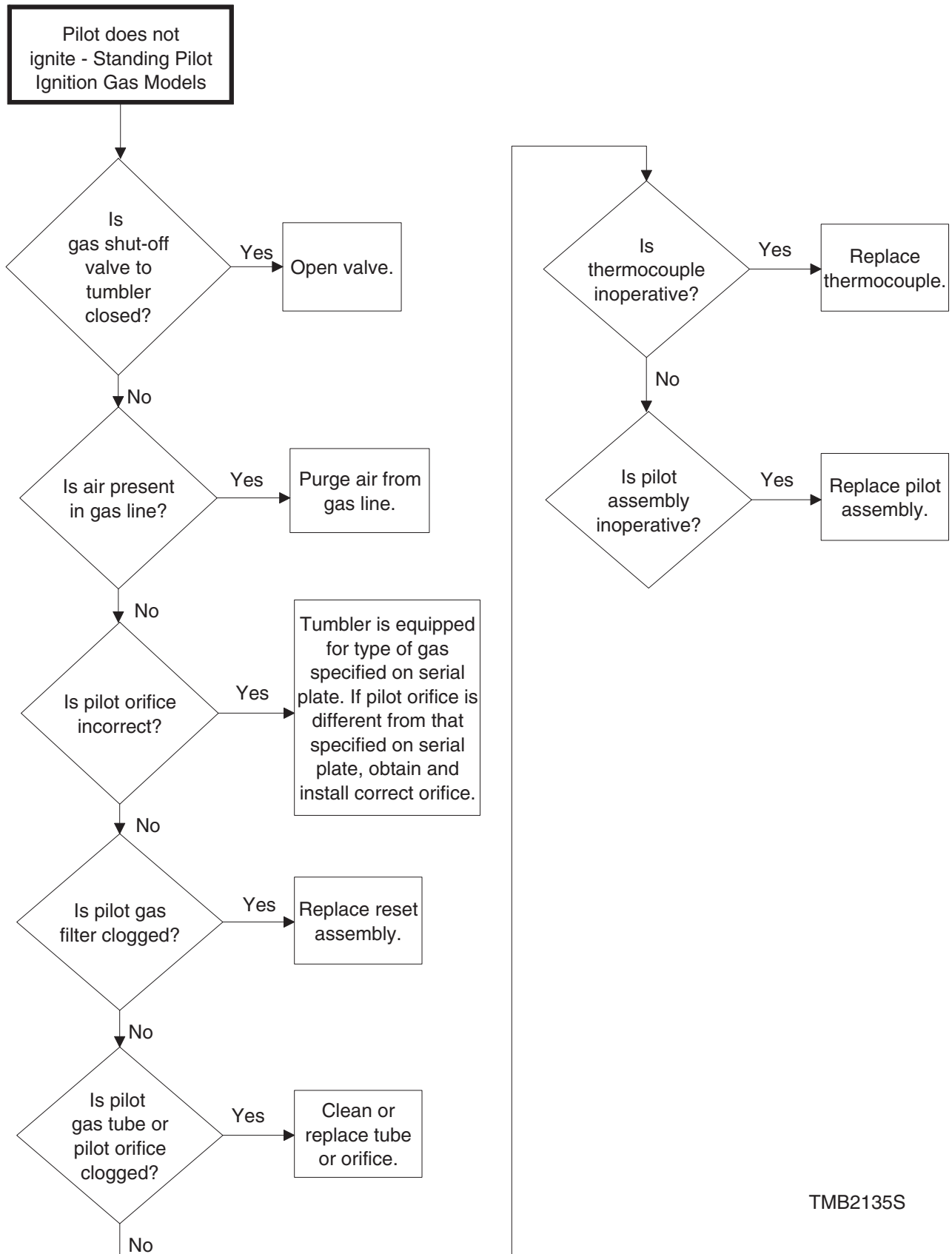

TMB2135S

7. Pilot Goes Out – Standing Pilot Ignition Gas Models

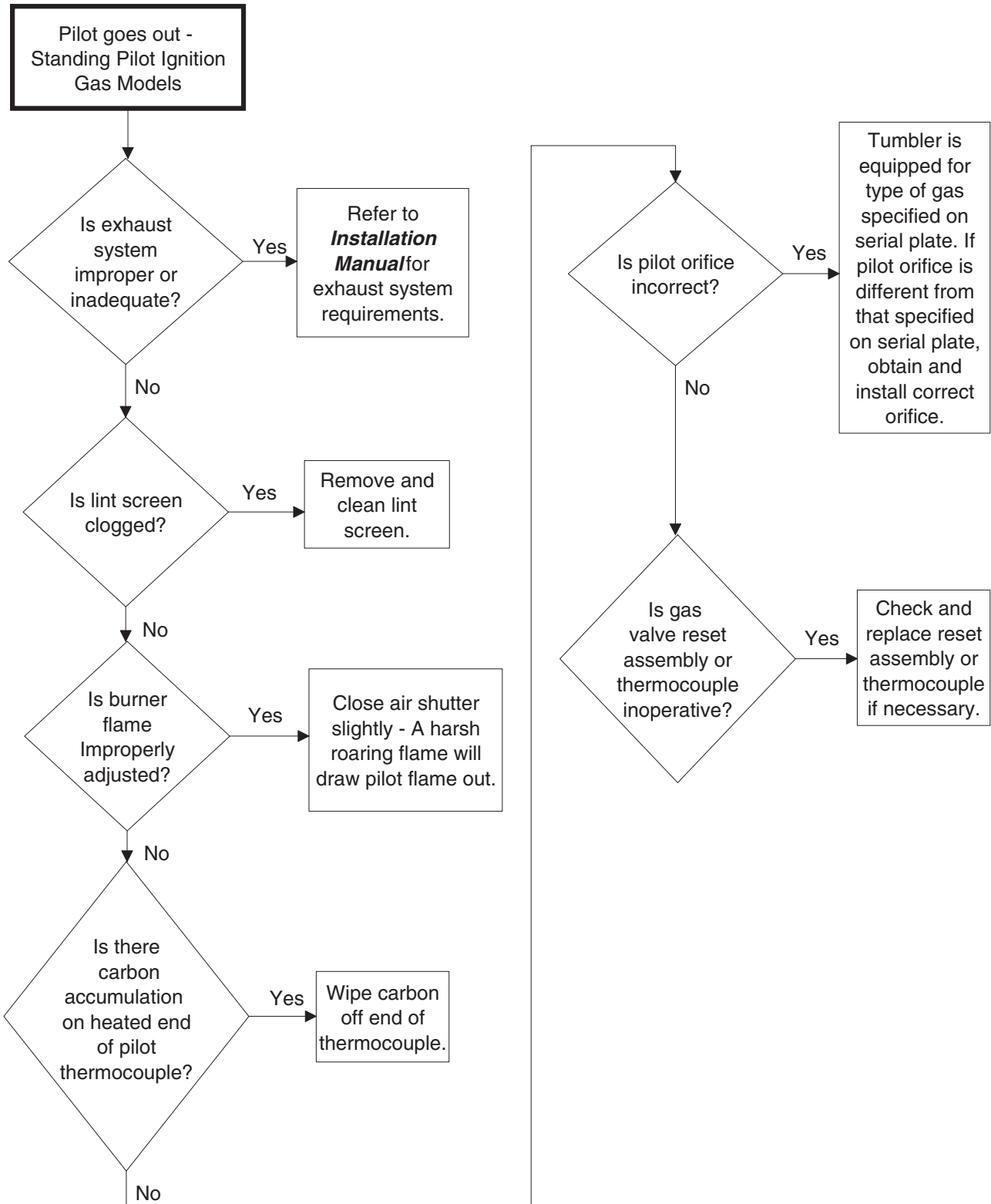

TMB2136S

8. Igniter Does Not Shut Off After Gas Ignition – Automatic Pilot Ignition Gas Models

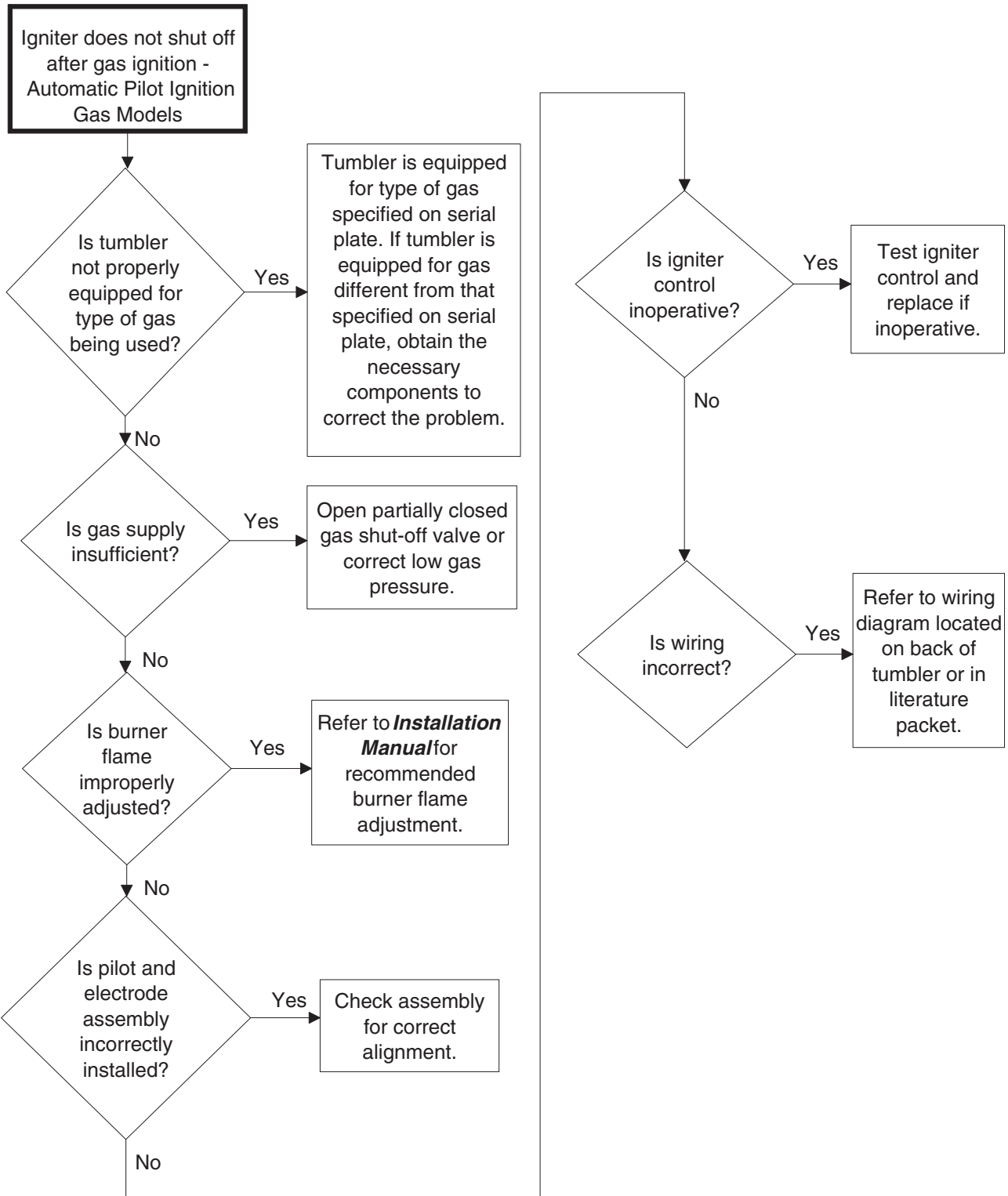

TMB2137S

9. Gas Supply Sufficient But Igniter Does Not Glow – Glow-Bar Ignition Gas Models

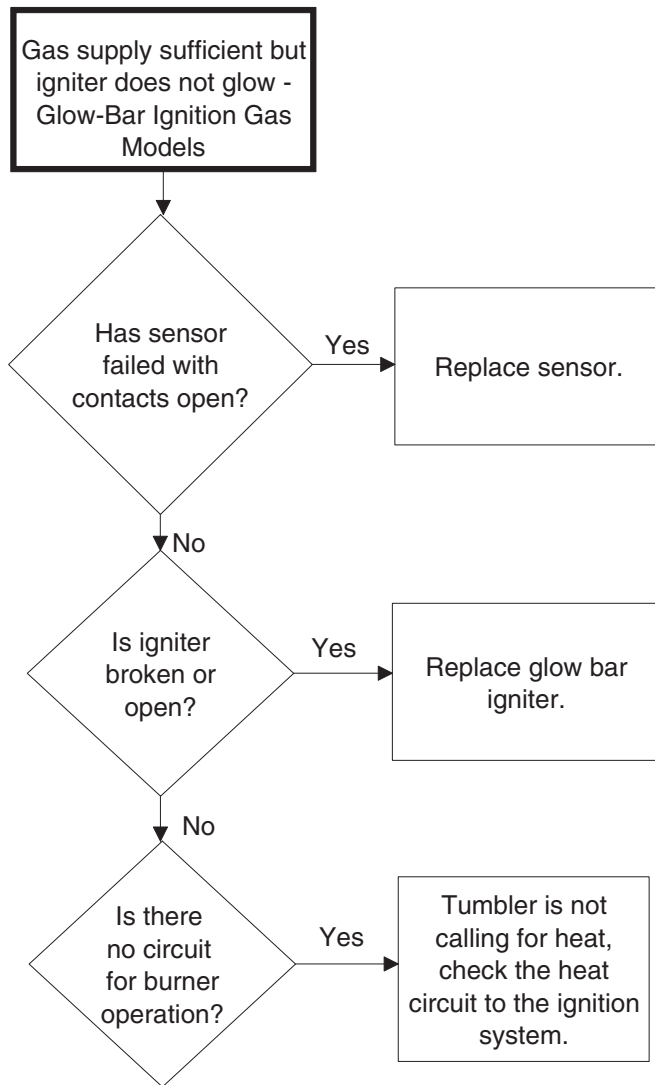

TMB2138S

10. Igniter Glows, Sensor Opens But No Ignition – Johnson Controls System Gas Models

NOTE: To check the primary and secondary valve coil and plunger operation, place fingers on top of coils, cycle the machine and restart ignition circuit, you should feel the primary valve coil plunger open first, followed by glow bar heat up, followed by the sensor opening, and the secondary valve coil plunger opening. If plungers do not open, electrically check the coils. Check gas pressure to tumbler. Line pressure should be $7 \pm 1/2$ inches (Natural Gas) or 11 inches (L.P. Gas) water column pressure. Manifold pressure should be 3.5 inches (Natural Gas) or 11 inches (L.P. Gas) water column pressure.

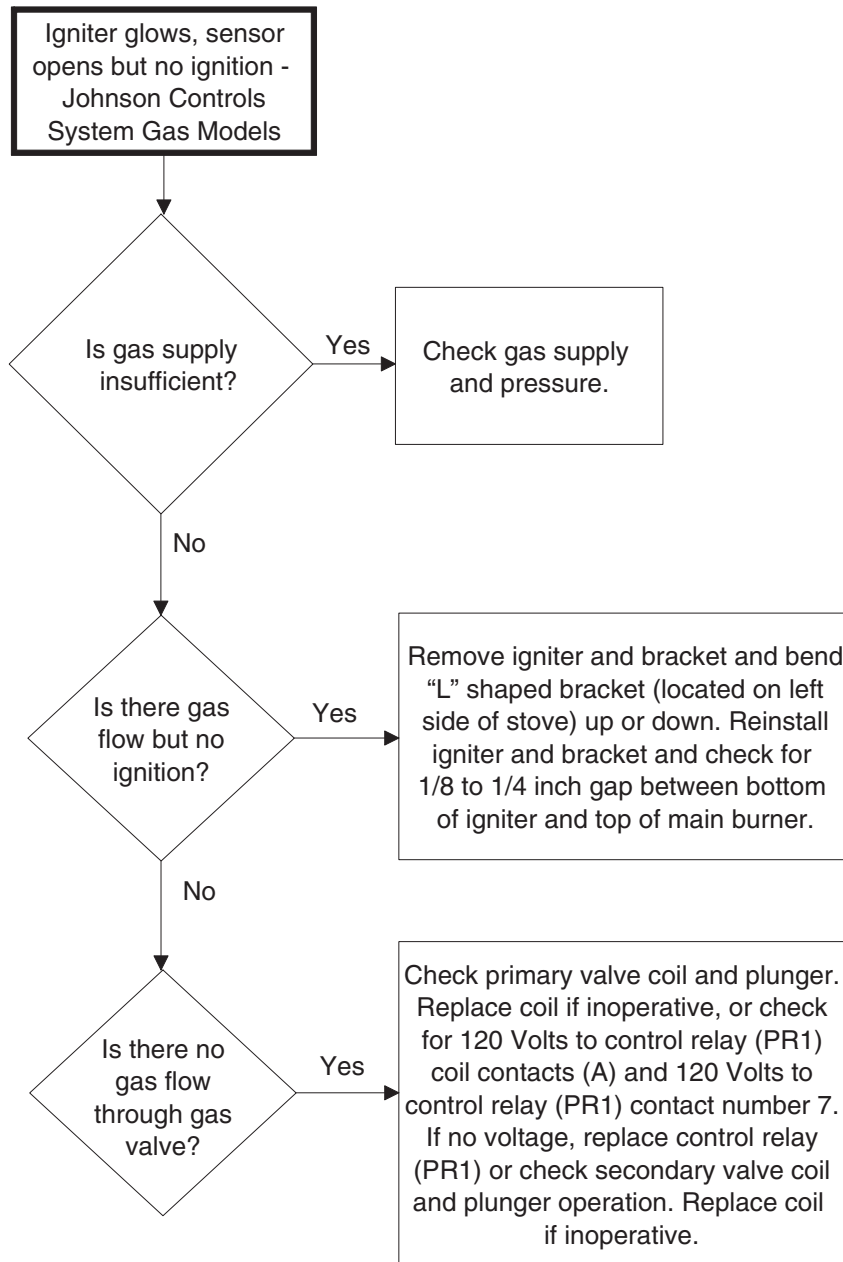

TMB2139S

11. Igniter Glows, Sensor Opens But No Ignition – White Rodgers Glow-Bar Ignition Gas Models

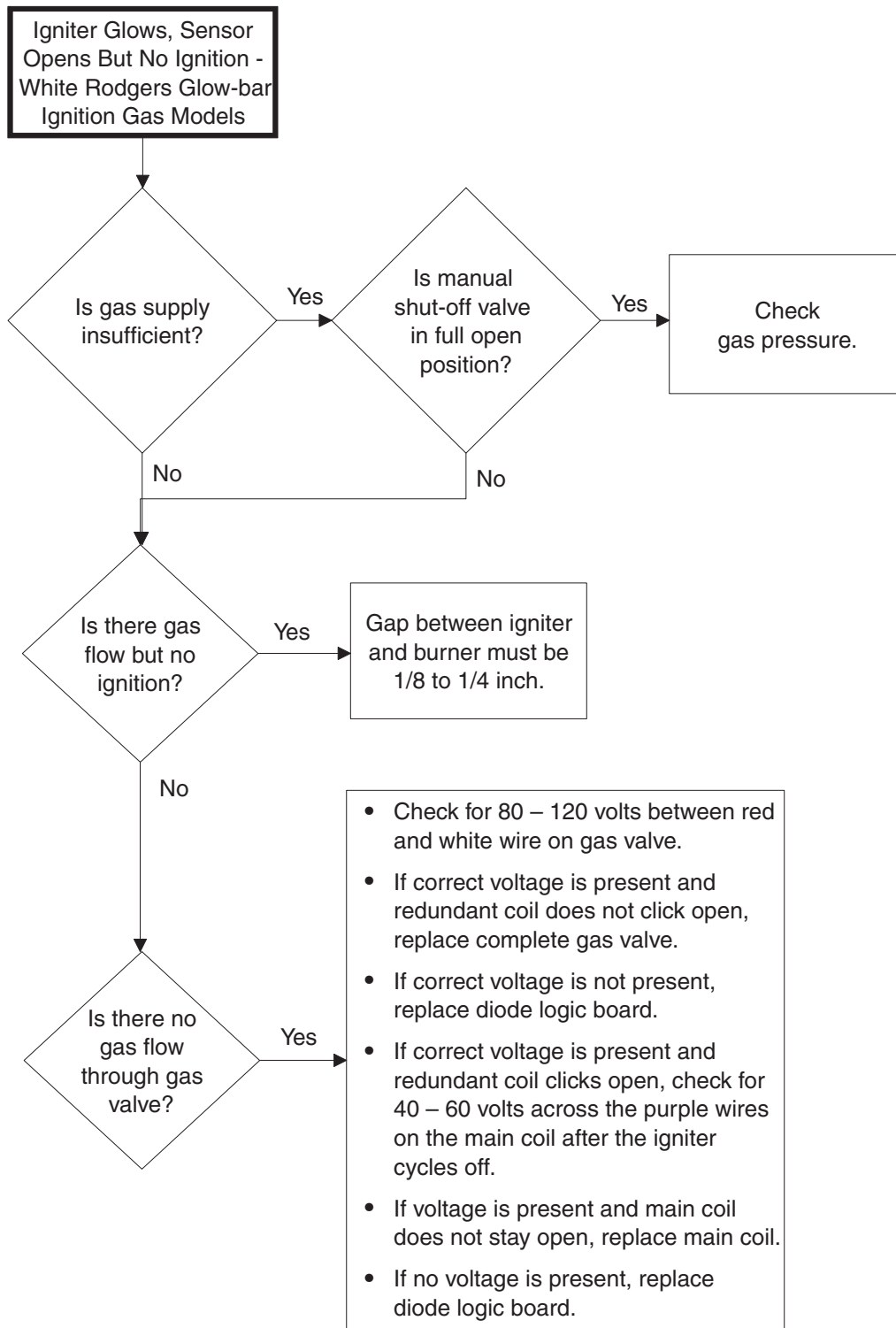

TMB2140S

12. Burner Ignites and Goes Out Repeatedly – Glow-Bar Ignition Gas Models

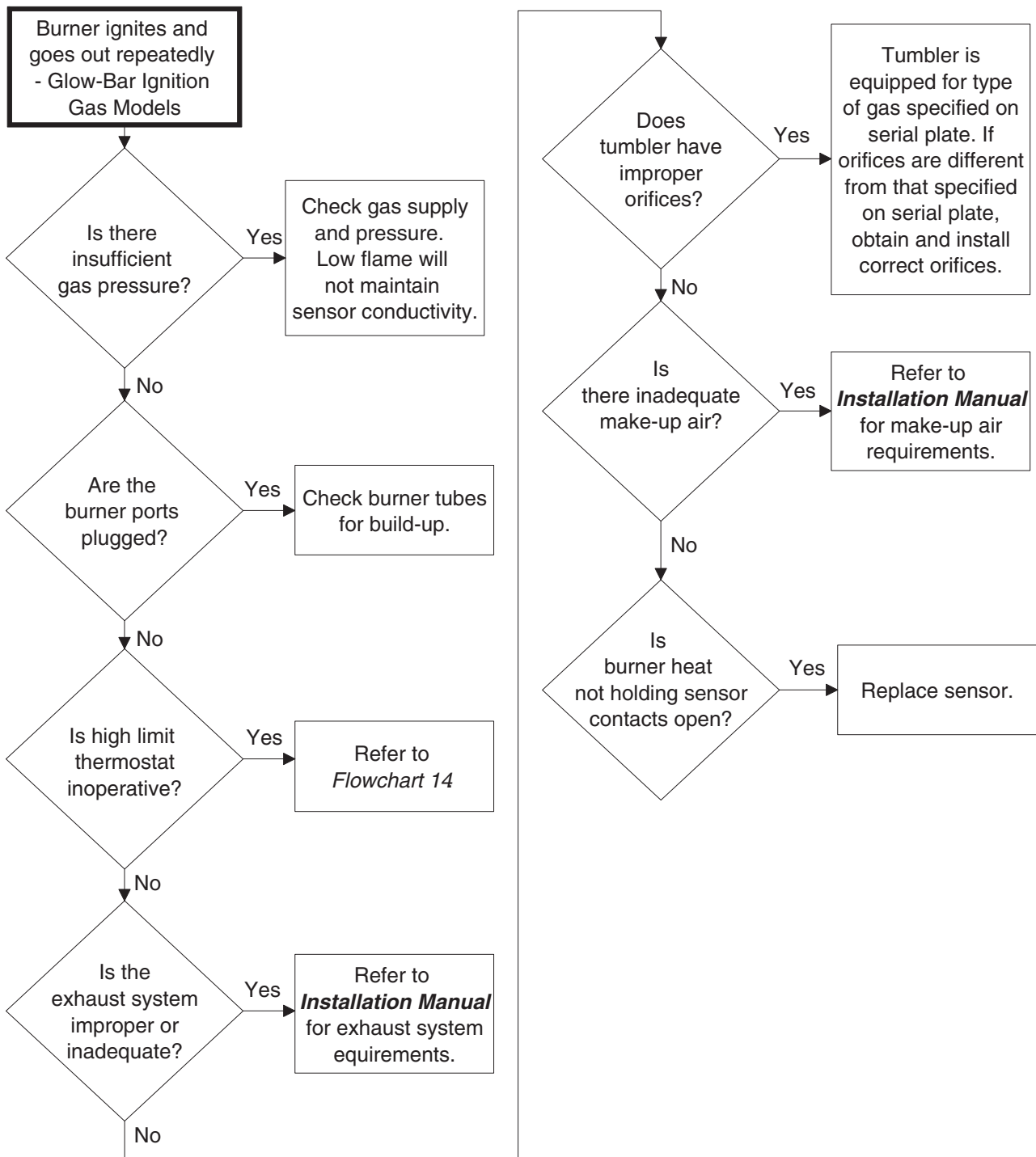

TMB2141S

13. Heating Element or Burner Shuts-Off Prematurely

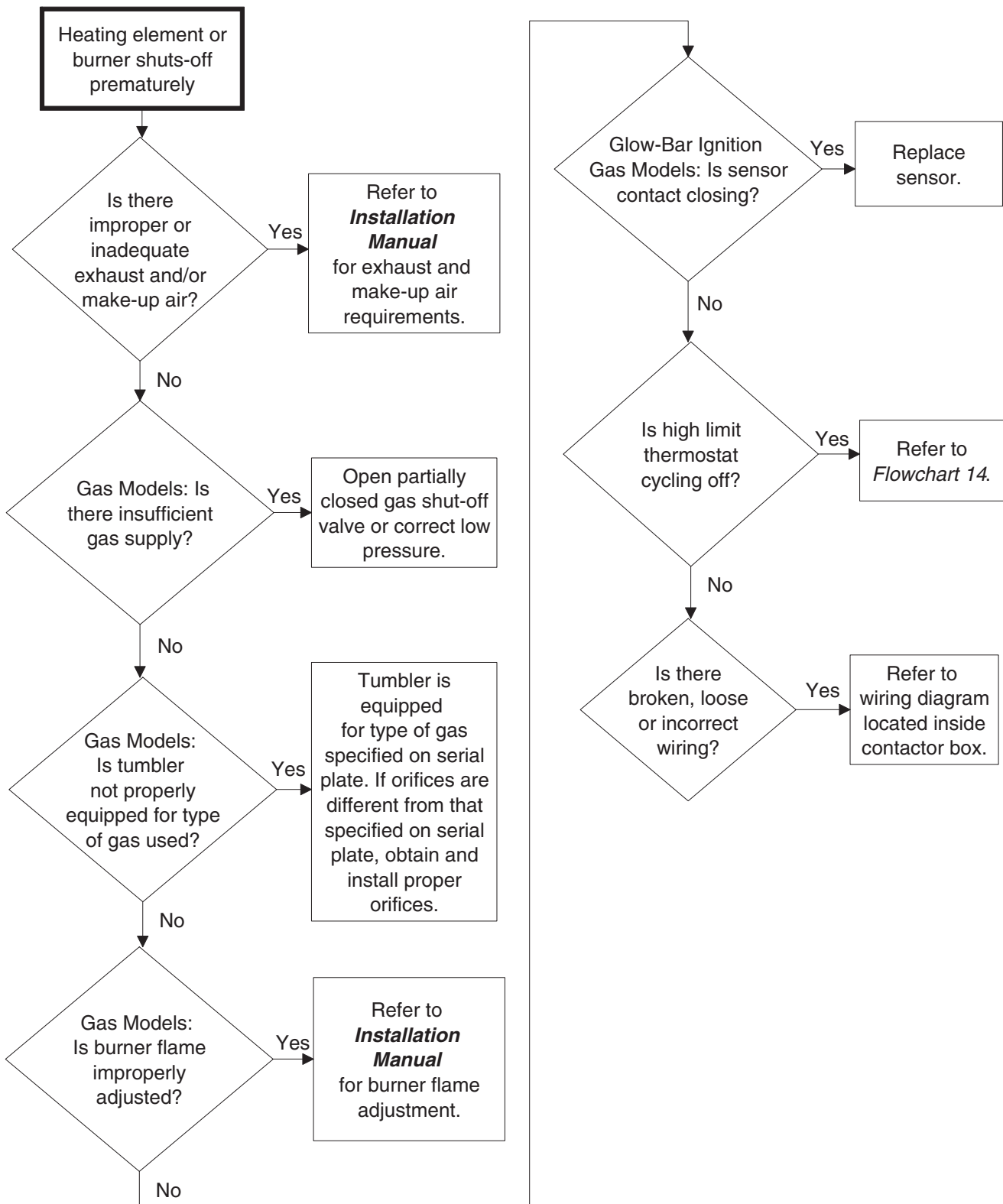

TMB2142S

14. Heating Element or Burner Repeatedly Cycles Off On High Limit Thermostat

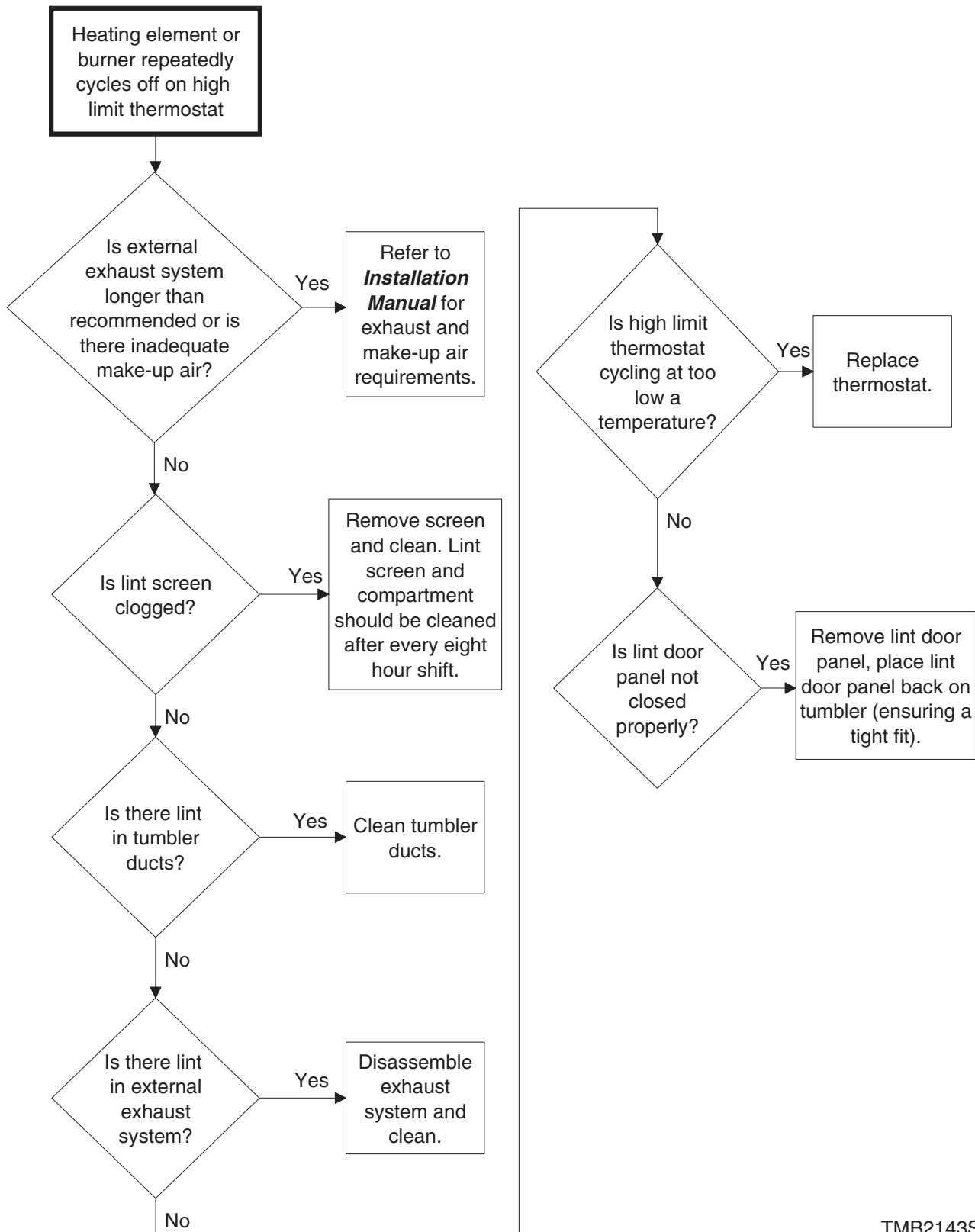

TMB2143S

15. Heating Element or Burner Does Not Shut-Off

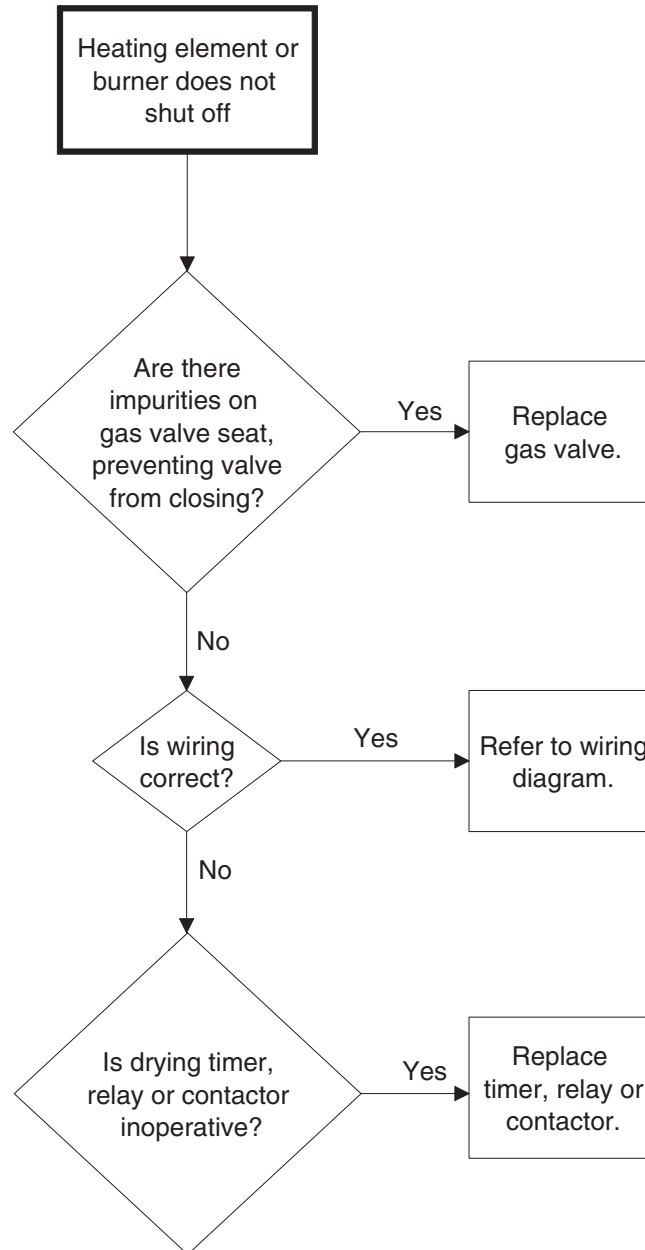

TMB2144S

16. Clothes Do Not Dry

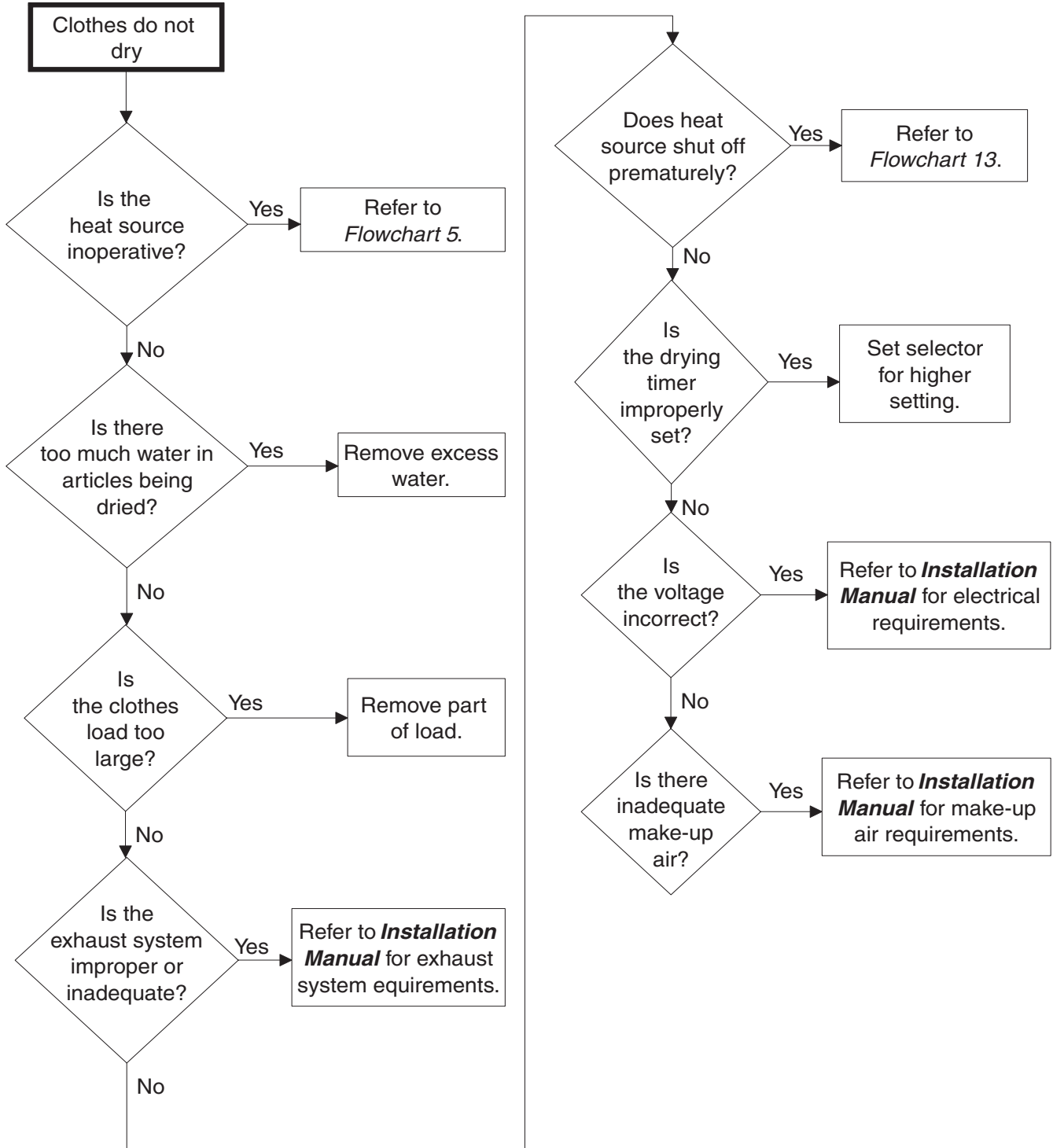

17. Tumbler Overheating

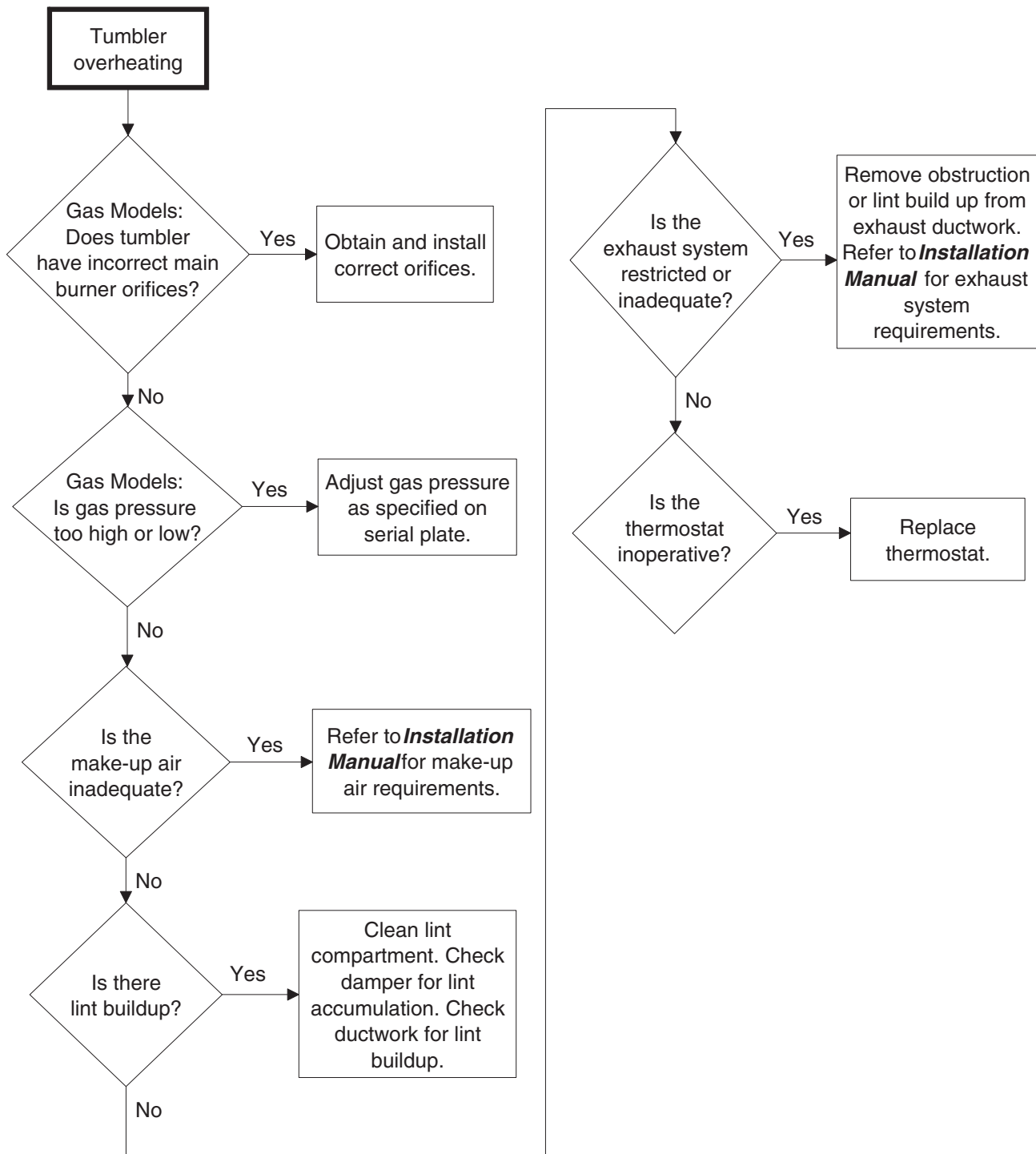

TMB2146S

18. Burners Not Burning Properly – Gas Models

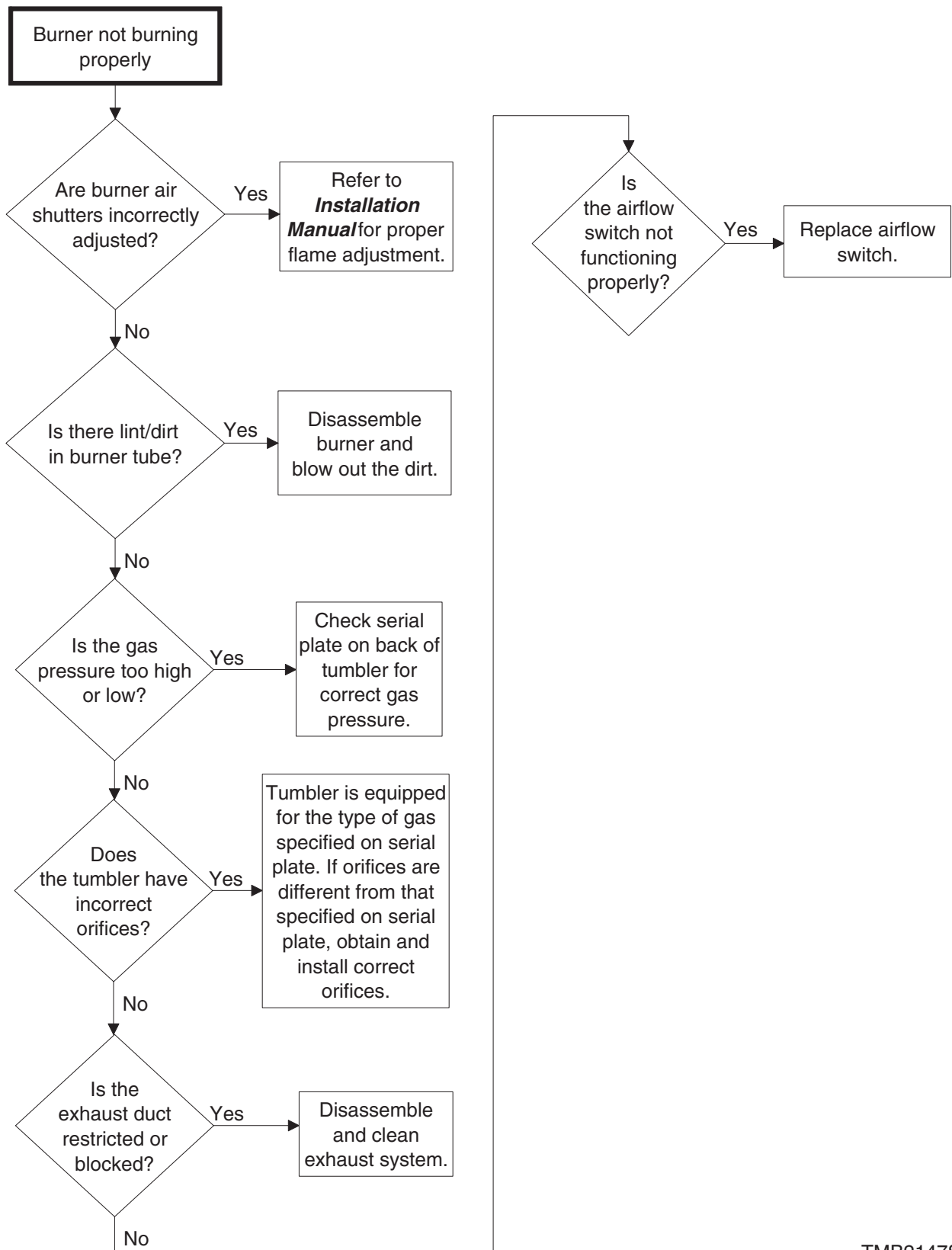

TMB2147S

19. Loading Door Opens During Operation

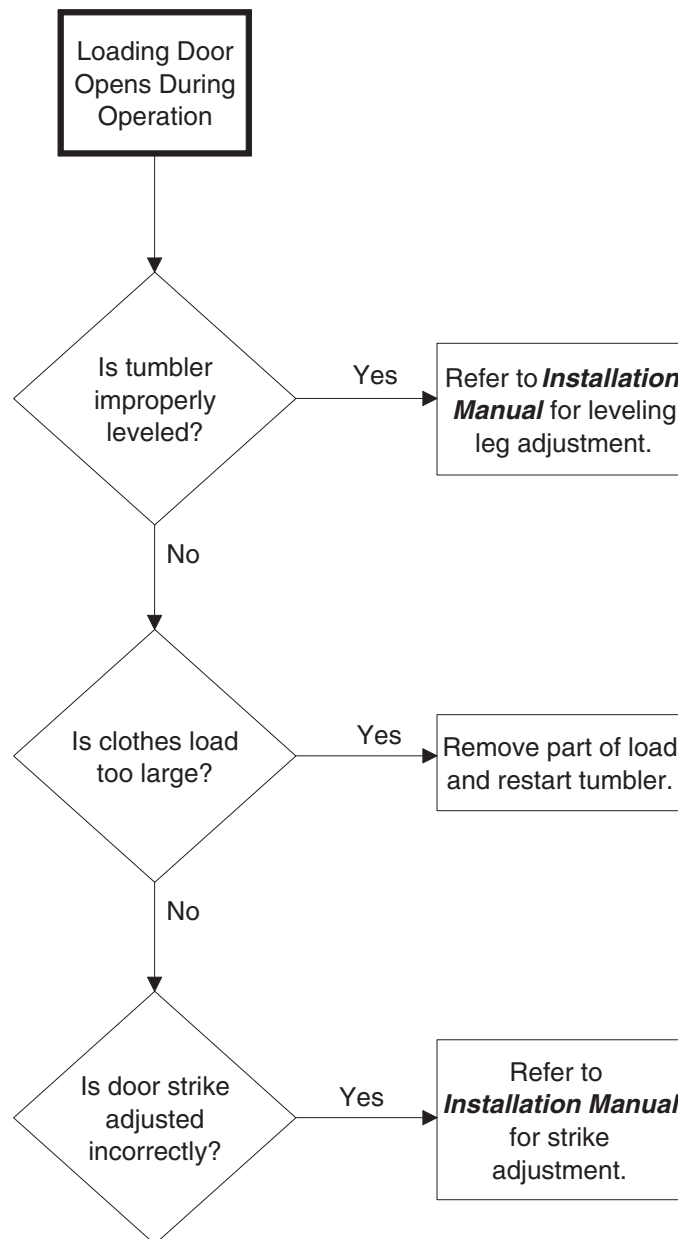

TMB2126S

20. Tumbler Runs But No Steam To Coils – Steam Models

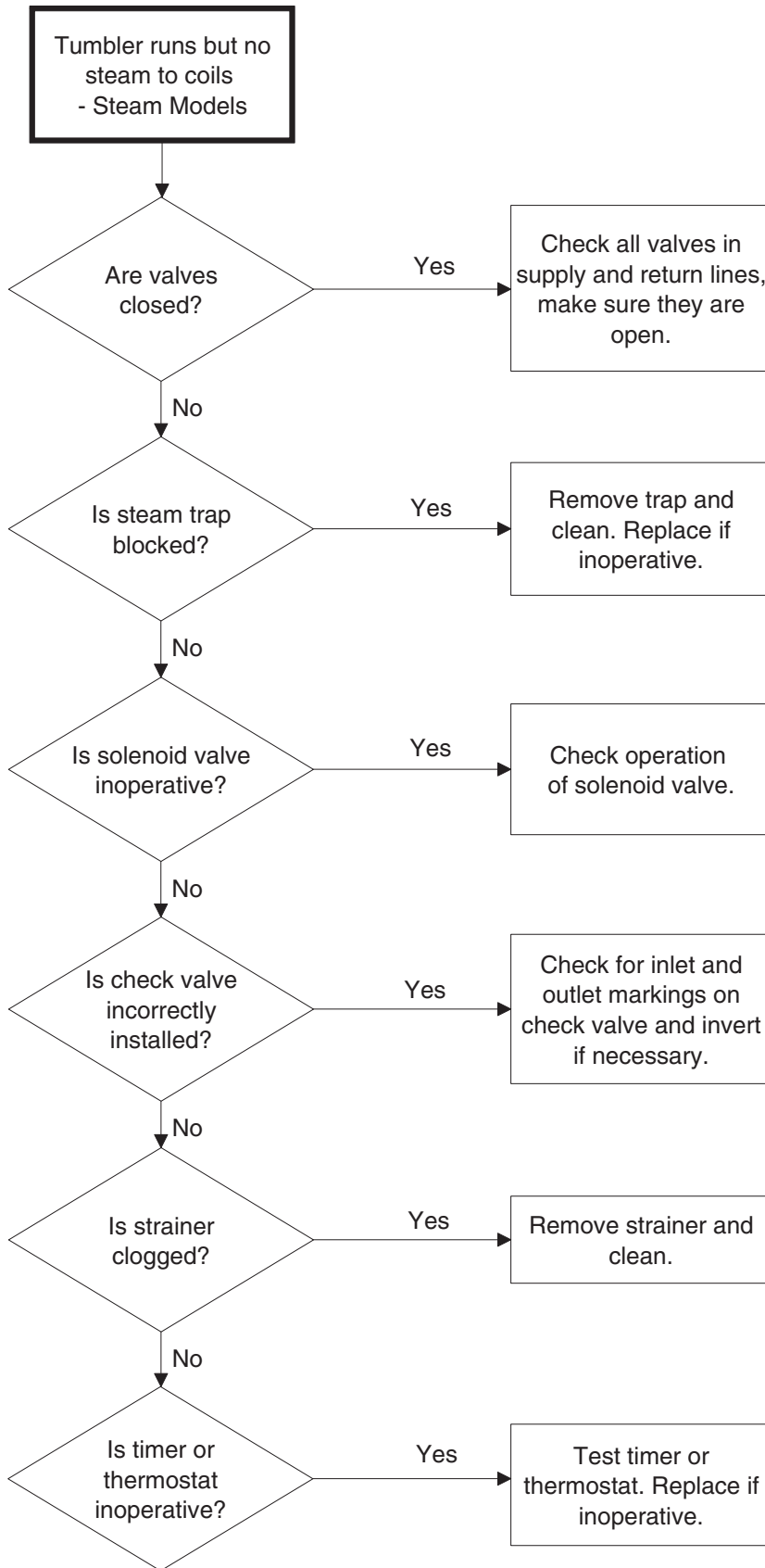

TMB2148S

21. Water In Steam Line – Steam Models

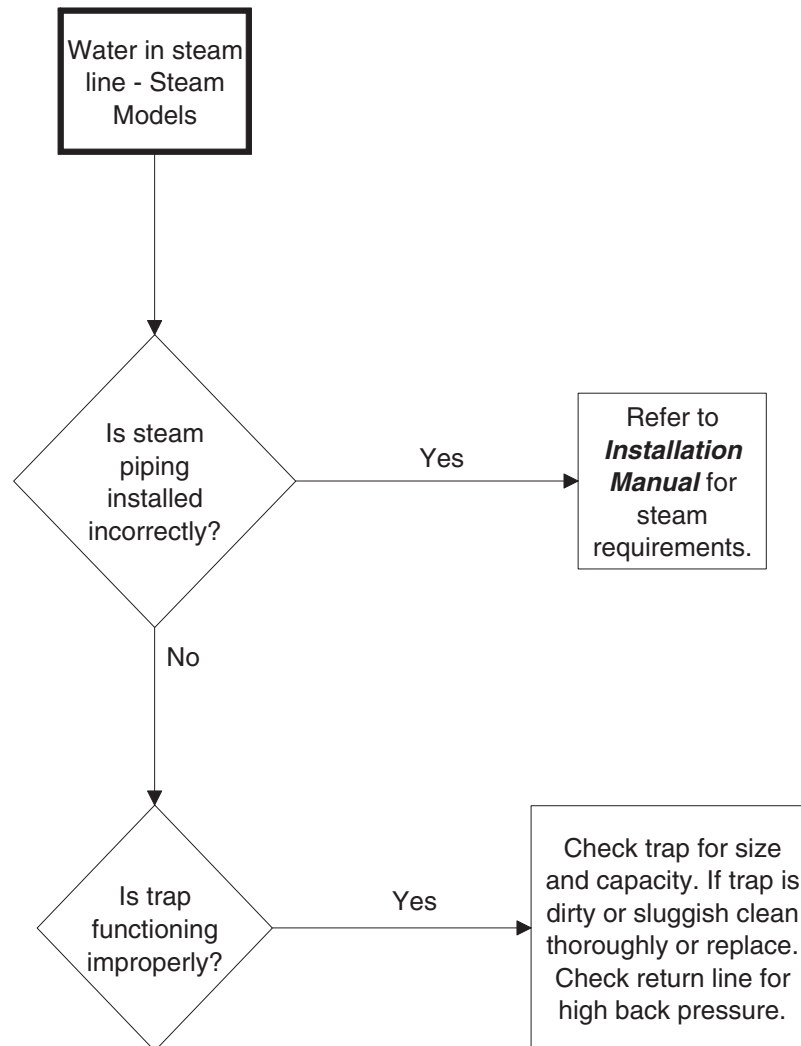

TMB1887S

22. Troubleshooting Electronic Control Models

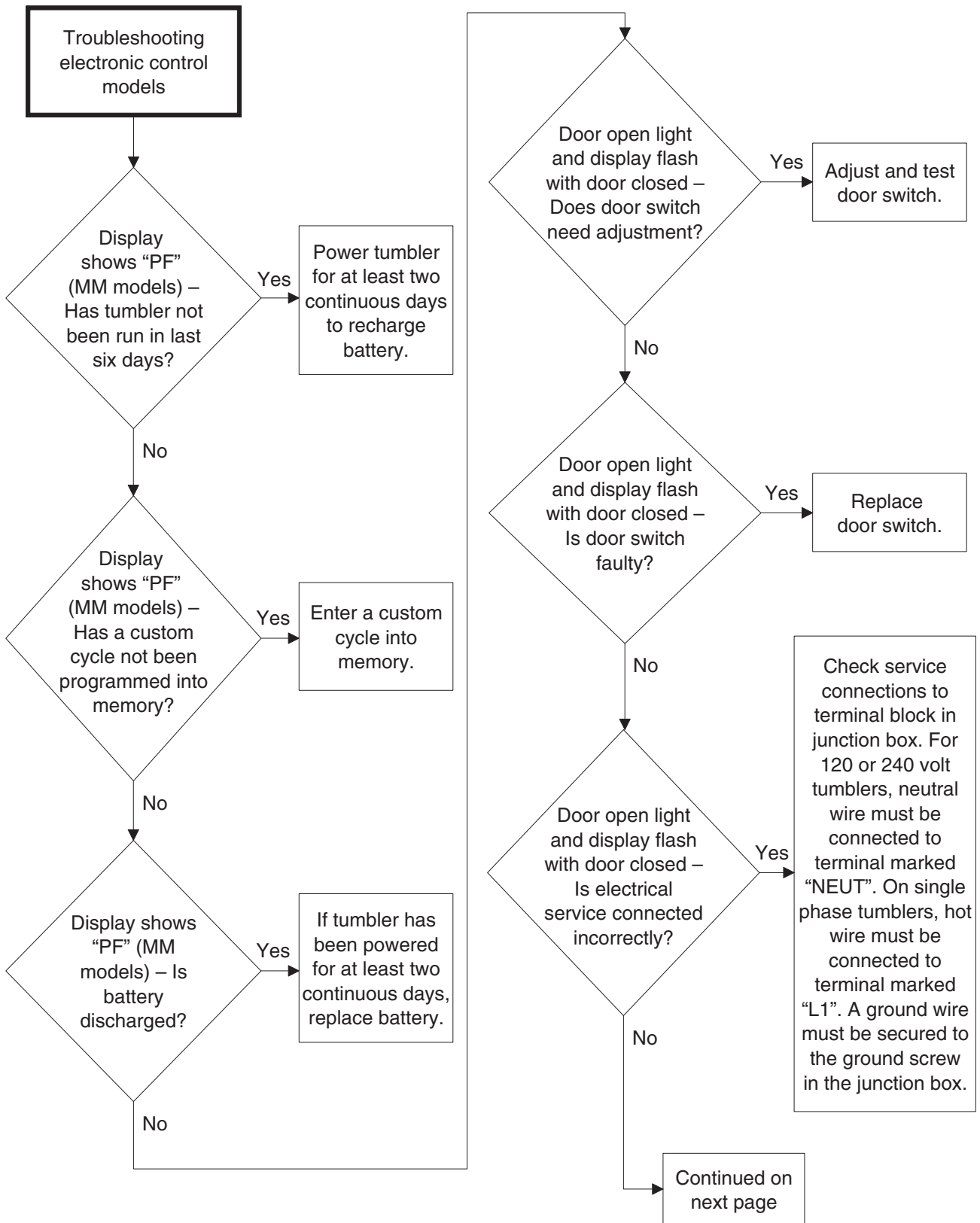

TMB2149S-a

22. Troubleshooting Electronic Control Models (continued)

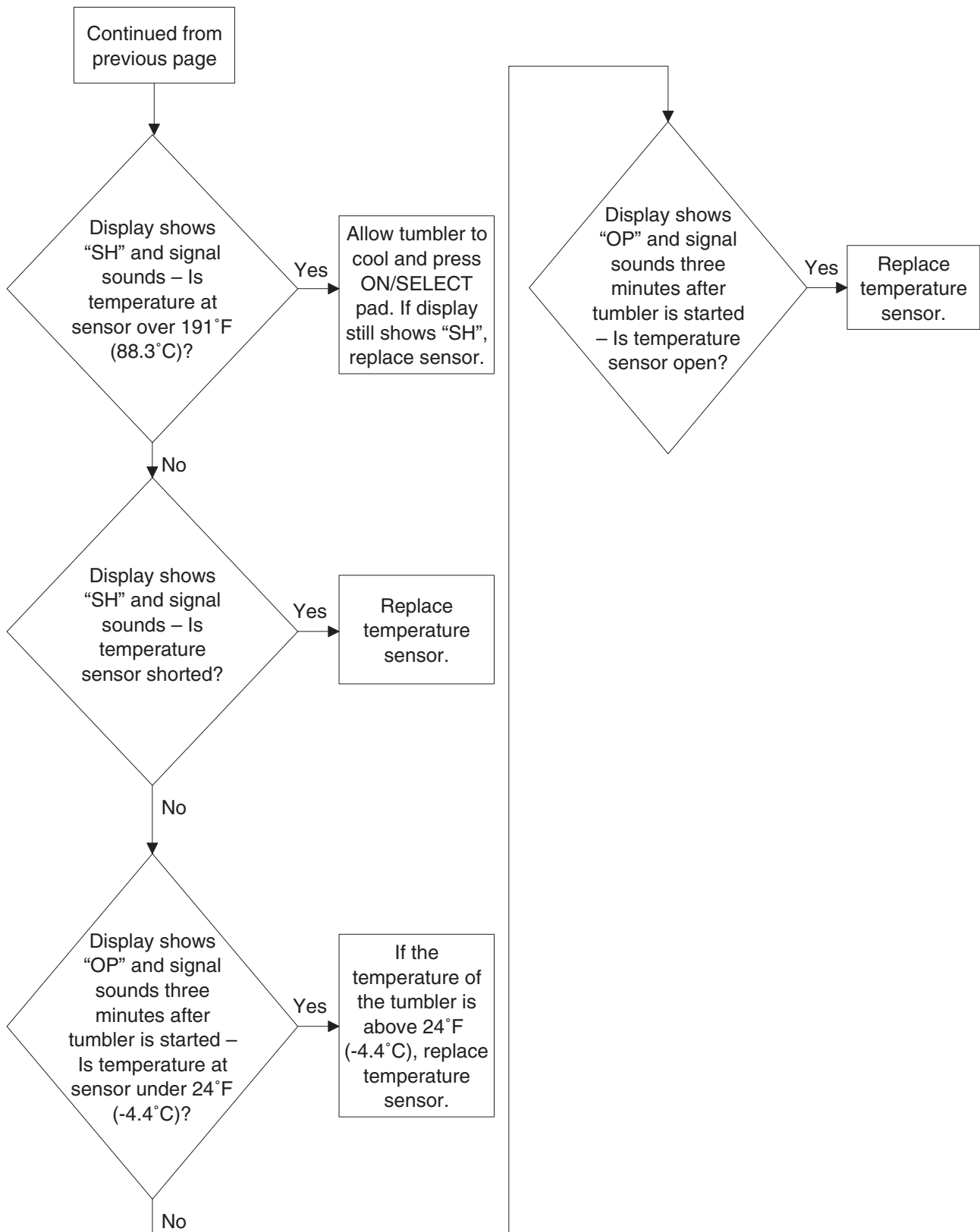

TMB2149S-b

23. Tumbler Will Not Start, Time on Drying Timer, Door Closed – Manual Timer Models

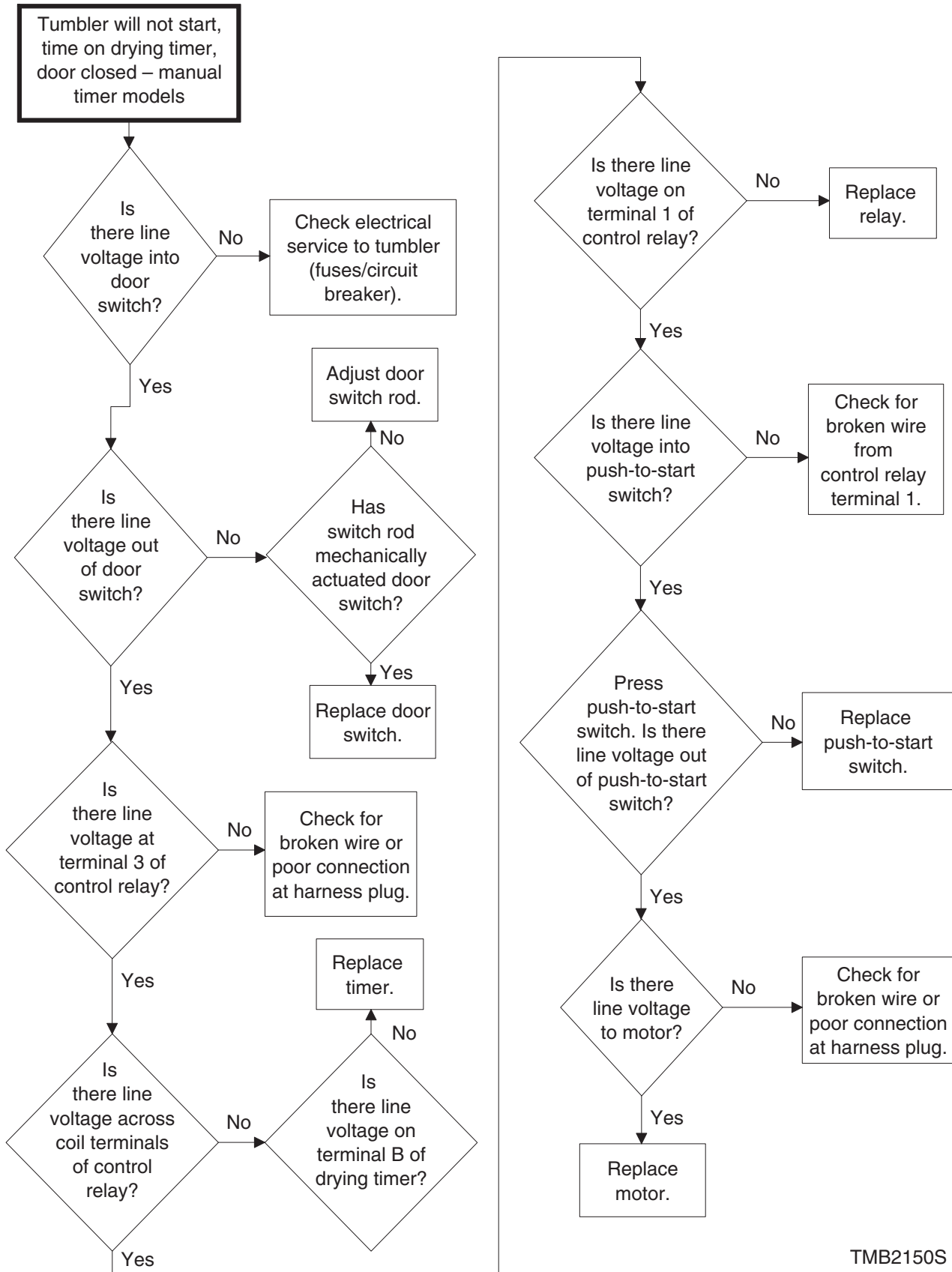

TMB2150S

24. Motor Runs, Time on Drying Timer But No Heat

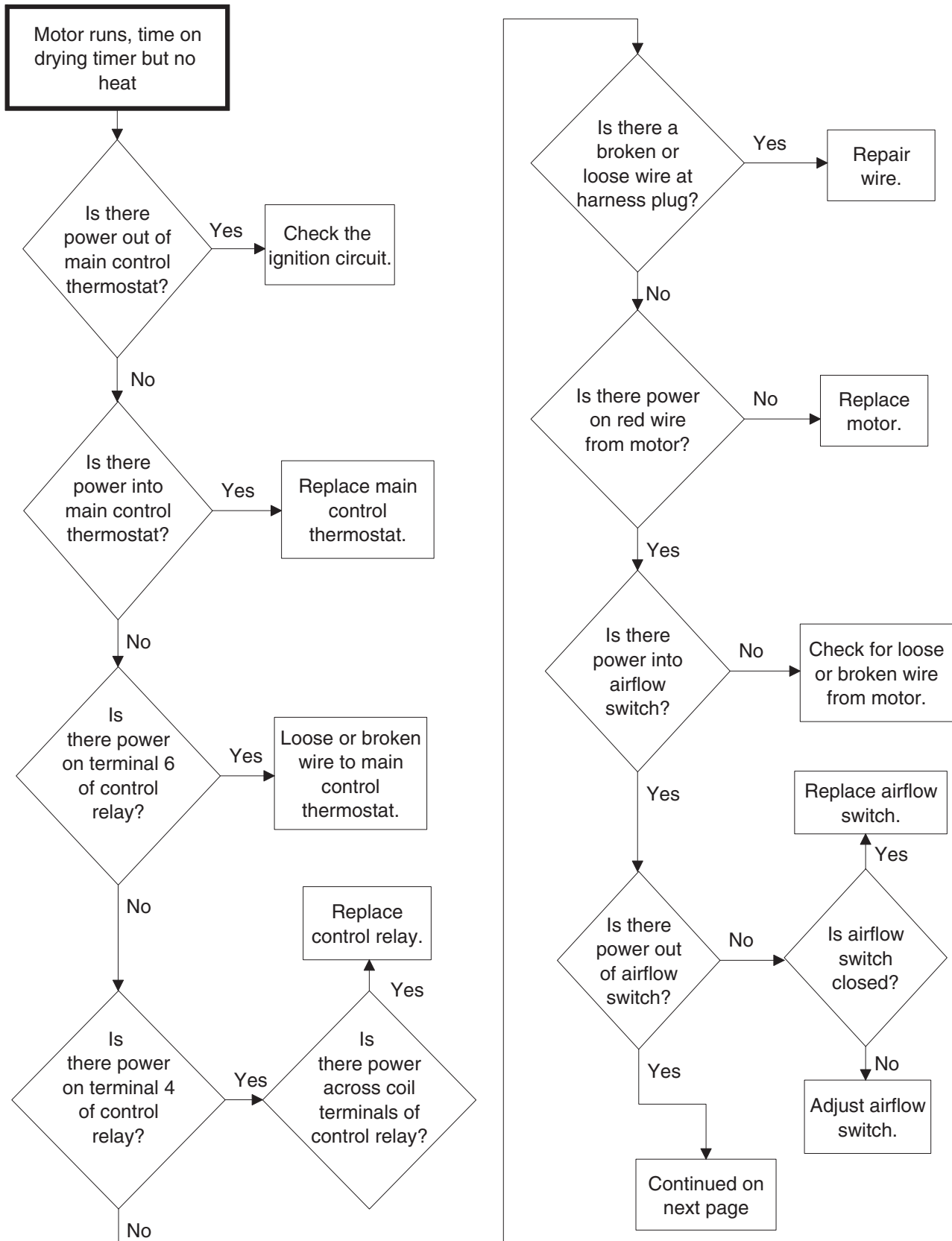

TMB2151S-a

24. Motor Runs, Time on Drying Timer But No Heat (continued)

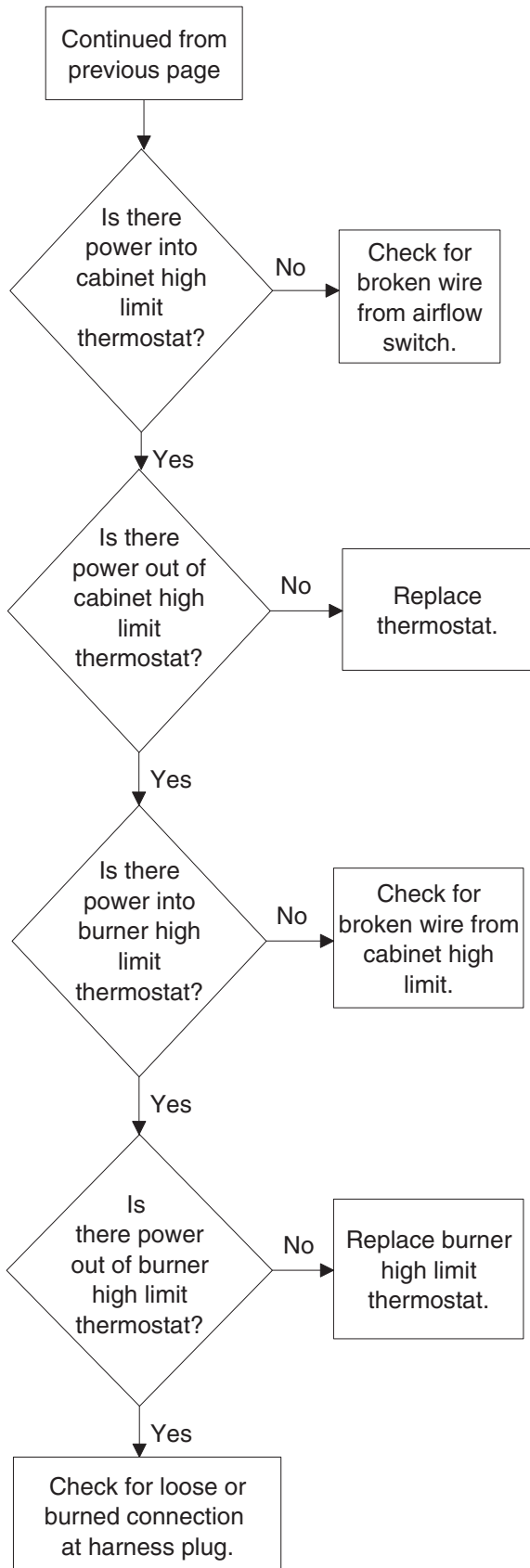

TMB2151S-b

25. No Spark to Pilot Burner – Electronic Pilot Ignition Models

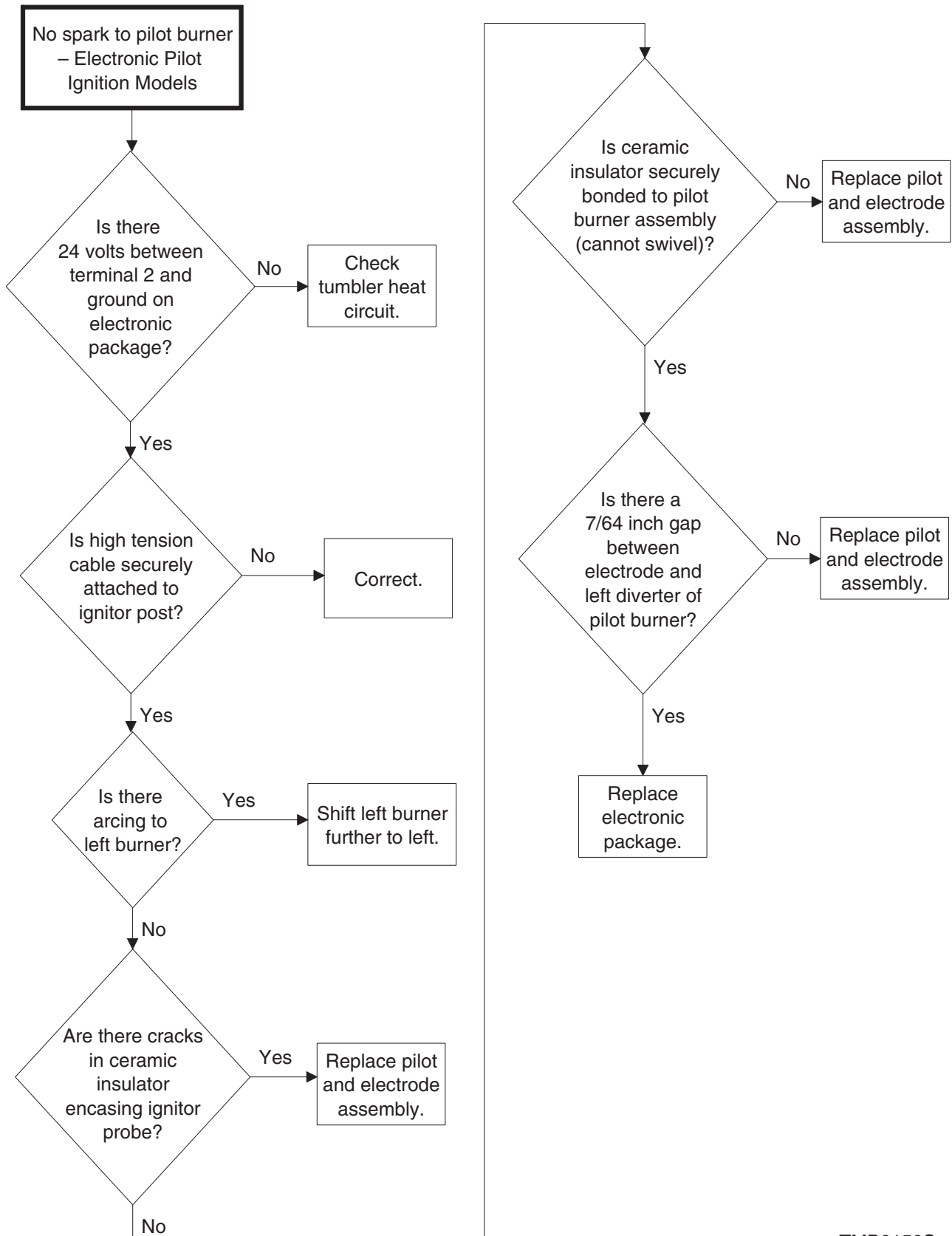

TMB2152S

26. Spark to Pilot Burner, No Pilot Flame – Electronic Pilot Ignition Models

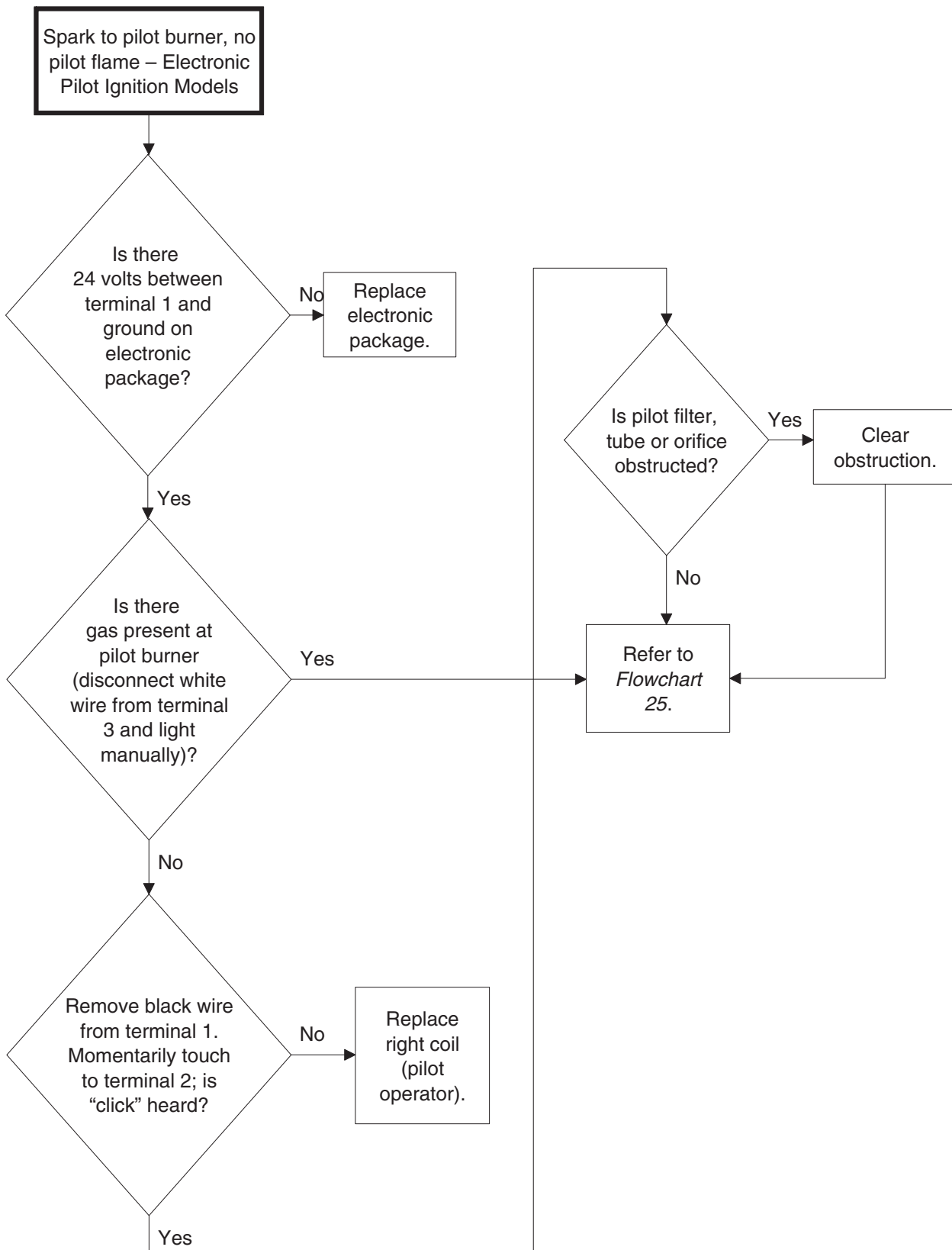

TMB2153S

27. Spark To Pilot Burner, Pilot Lights, No Main Burner – Electronic Pilot Ignition Models

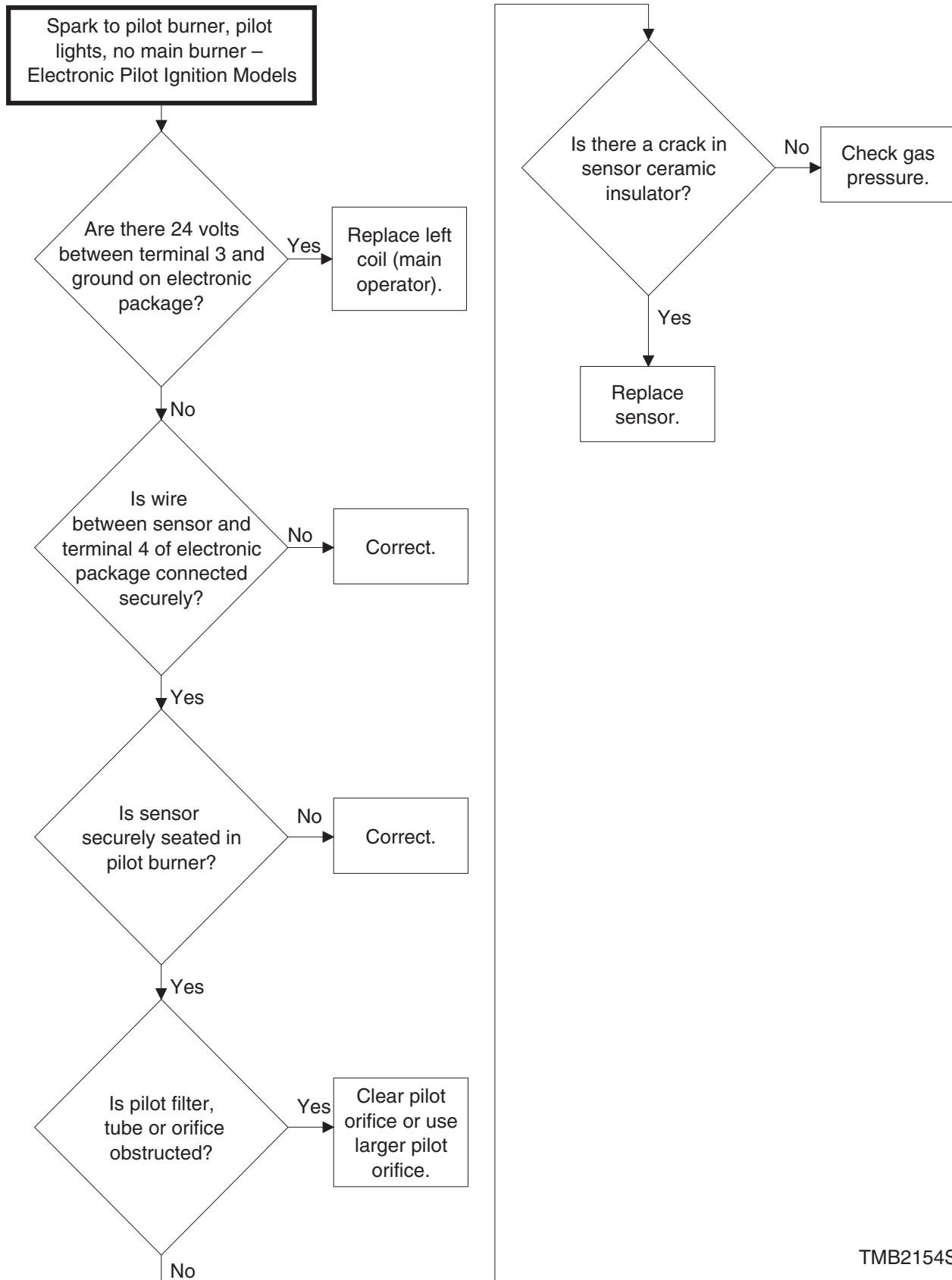

TMB2154S

28. Igniter Does Not Glow – Johnson Controls Glow-Bar System

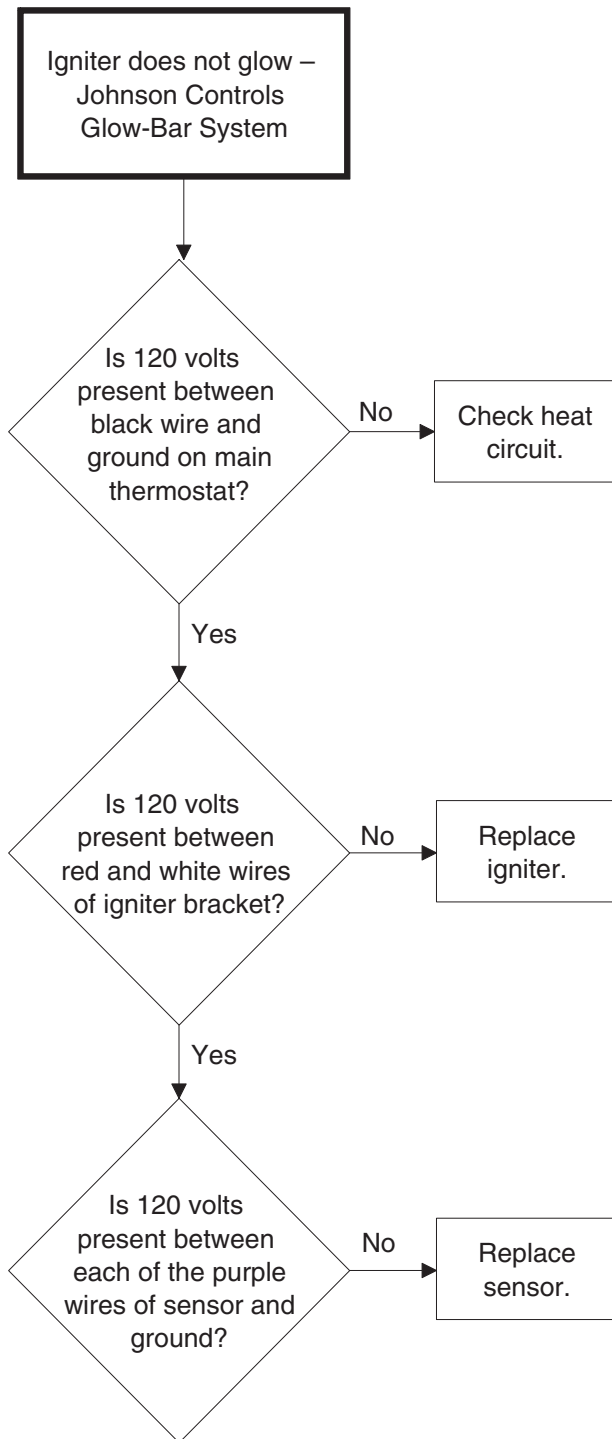

29. Igniter Glows Constantly – Johnson Controls and White Rodgers Glow-Bar System

Igniter glows constantly –
Johnson Controls and
White Rodgers
Glow-Bar System



Replace
sensor.

TMB2156S

30. Igniter Glows, Cycles Off But Burner Does Not Ignite – Johnson Controls Glow-Bar System

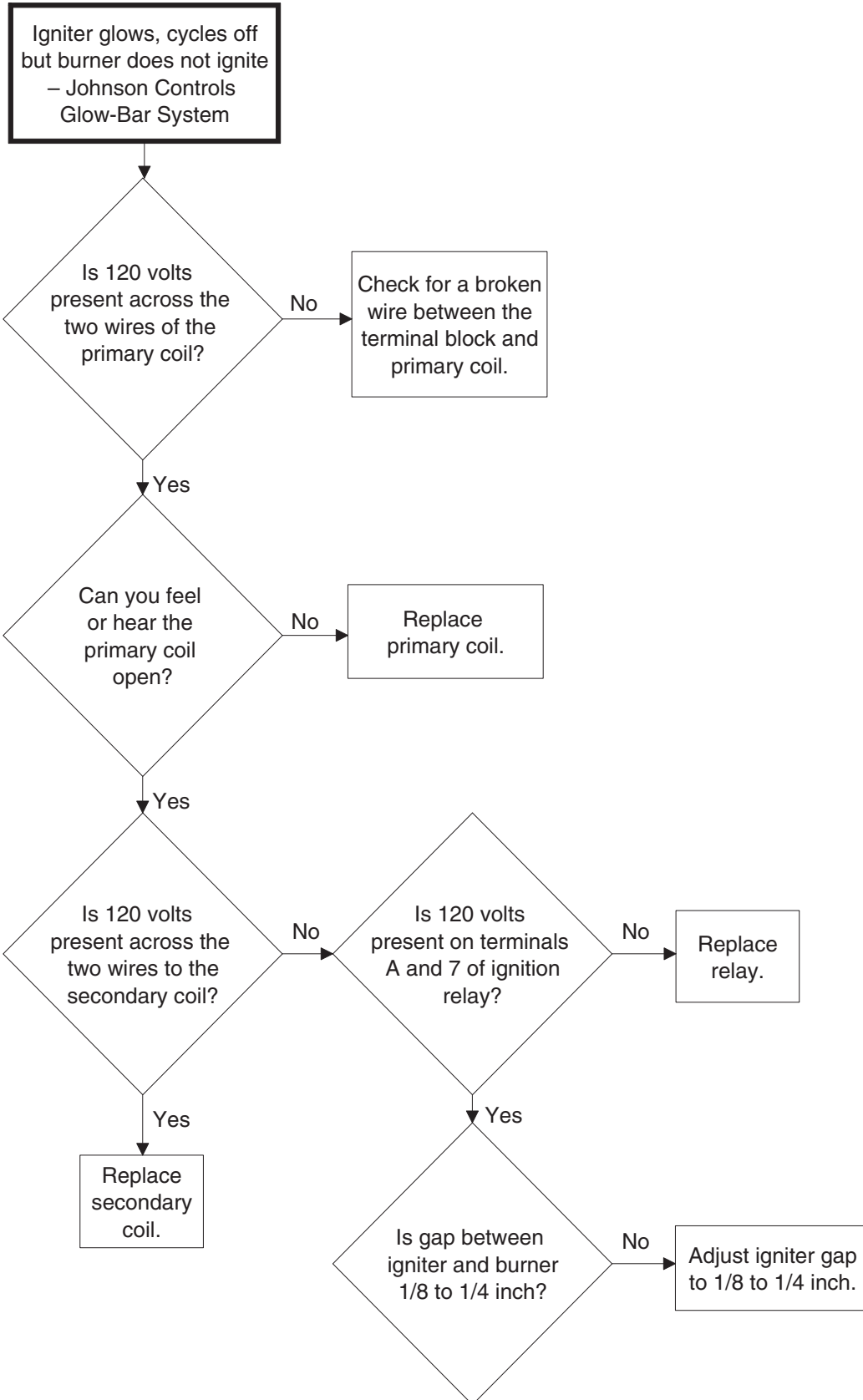

TMB2157S

31. Igniter Does Not Glow – White Rodgers Glow-Bar System

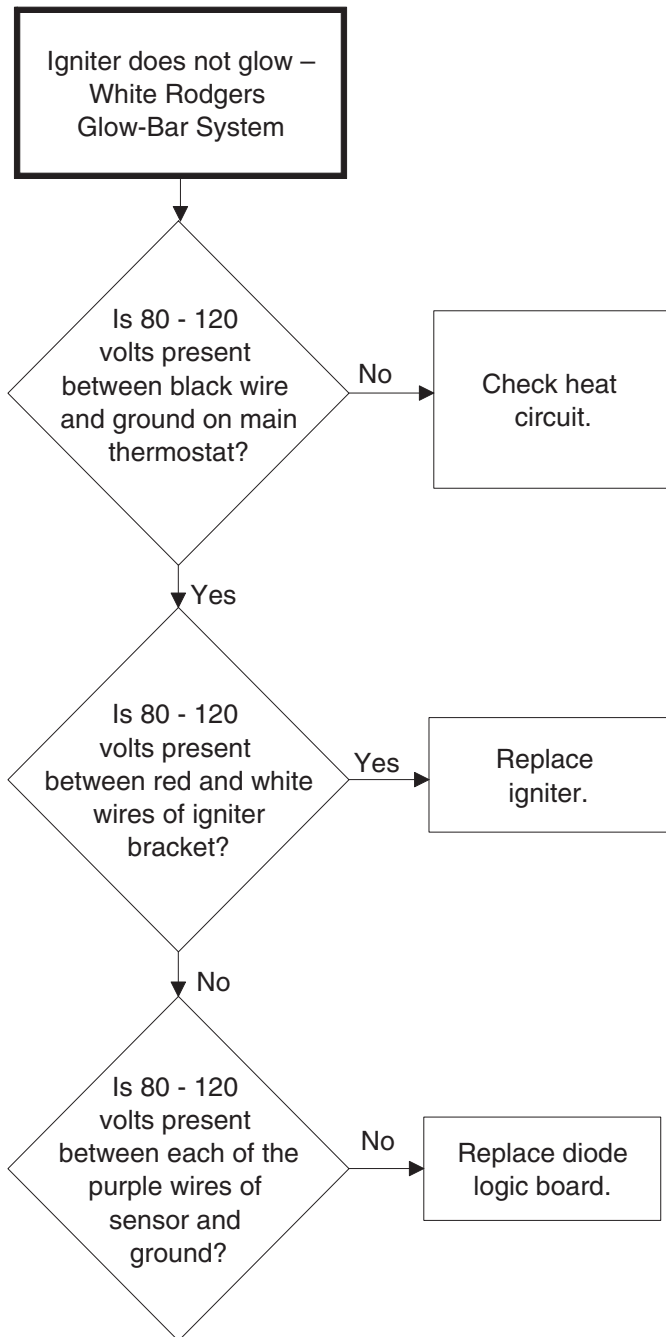

TMB2158S

32. Igniter Glows, Cycles Off But Burner Does Not Ignite – White Rodgers Glow-Bar System

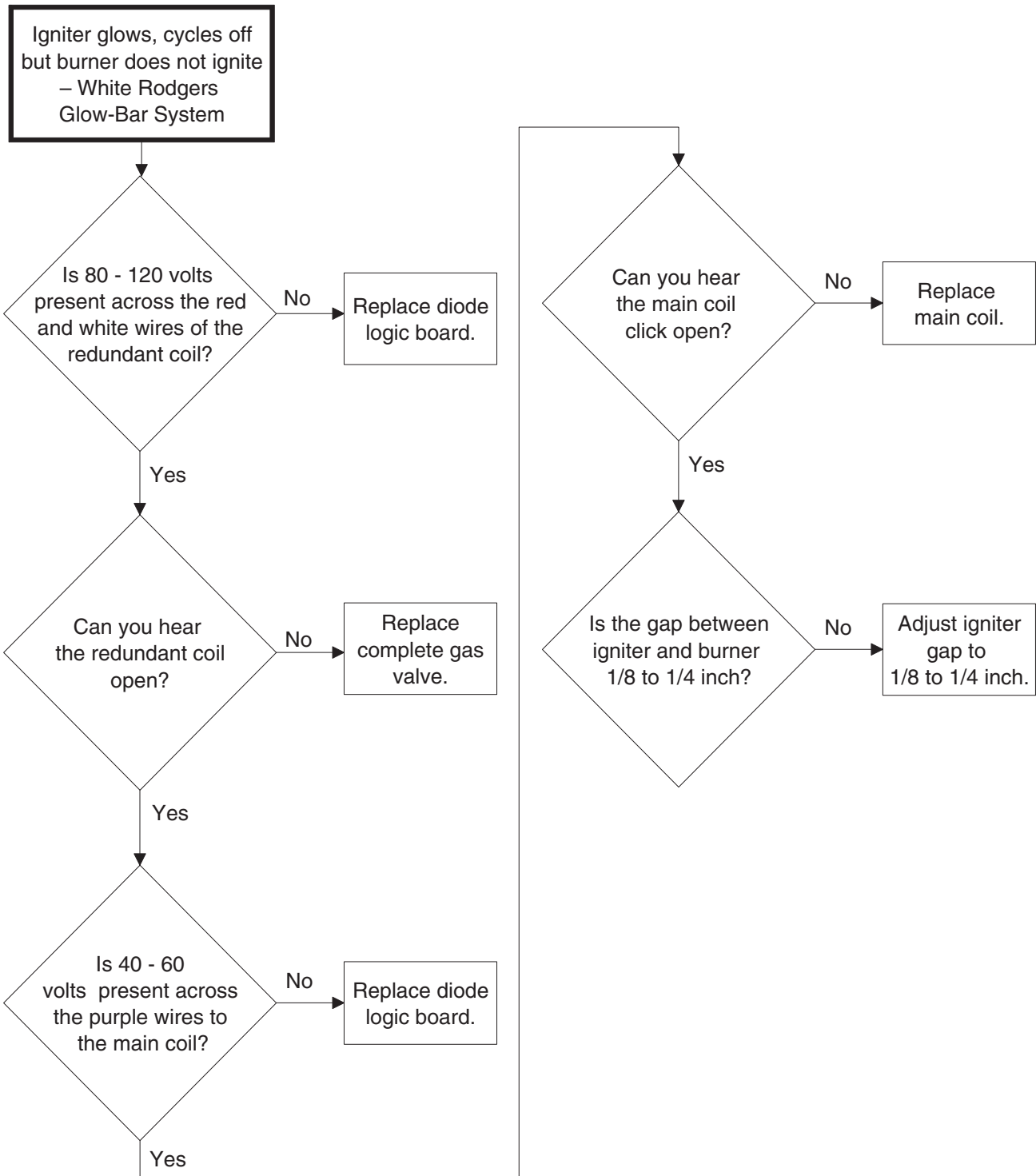

33. Igniter Sparks, No Main Burner Ignition – Instant Electronic Ignition

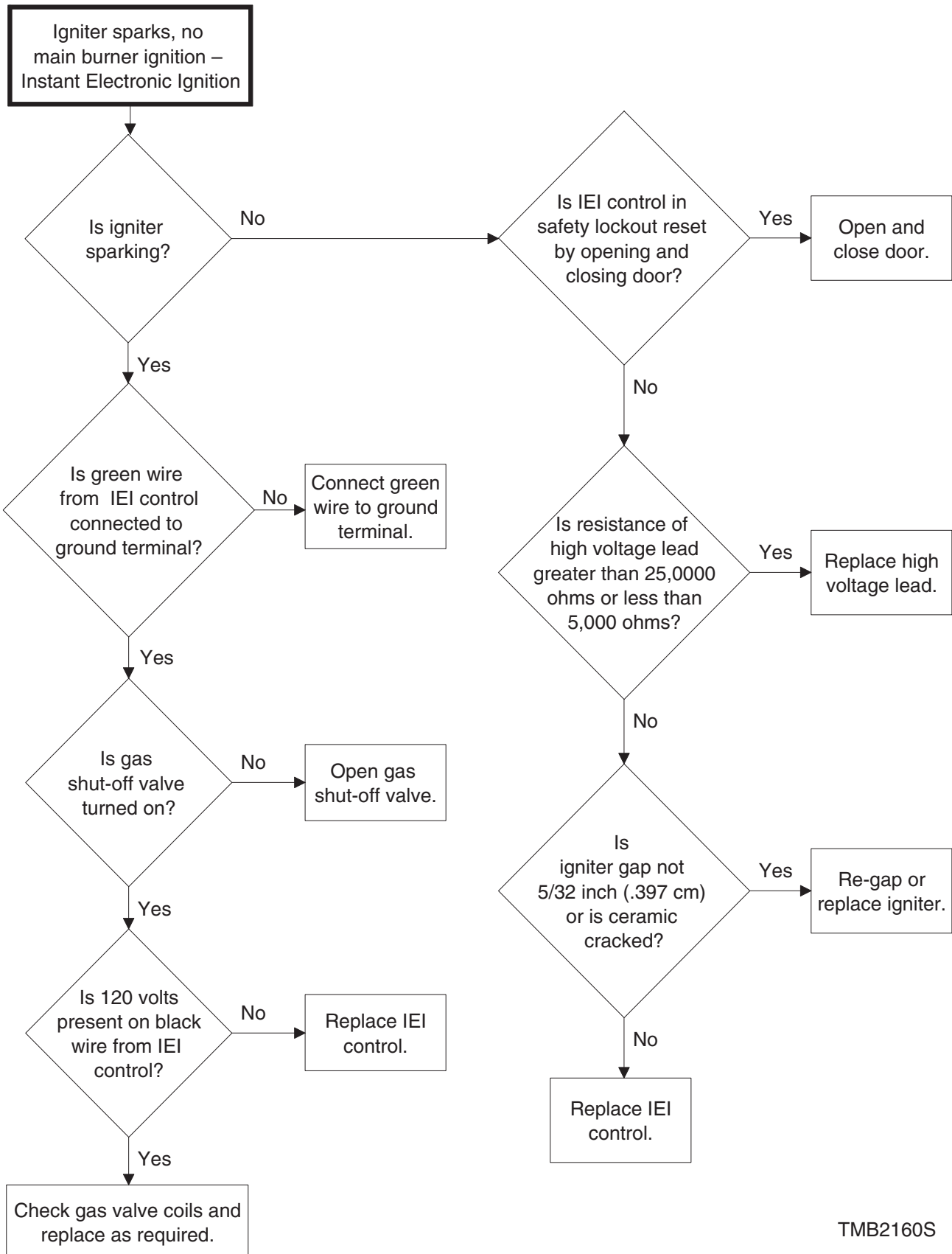

TMB2160S

34. CSH OM Models: No Heat With Cycle Selected, Unit Running and Calling For Heat

120 Volt/60 Hertz/1 Phase and 208-240 Volt/60 Hertz/1 Phase Nonreversing
 208-240 Volt/60 Hertz/3 Phase and 460-480 Volt/60 Hertz/3 Phase Reversing and Nonreversing

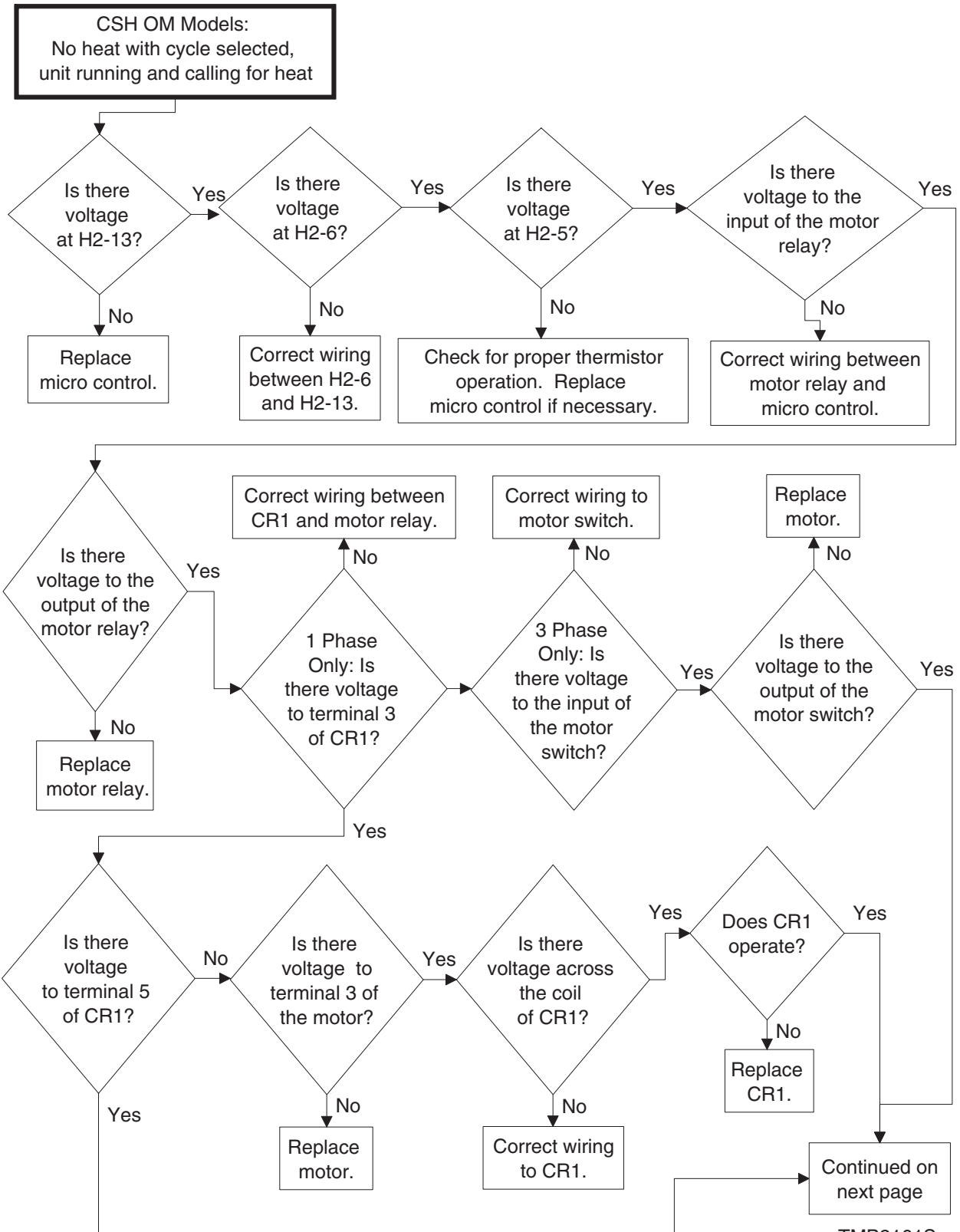

TMB2161S-a

34. CSH OM Models: No Heat With Cycle Selected, Unit Running and Calling For Heat (continued)

120 Volt/60 Hertz/1 Phase and 208-240 Volt/60 Hertz/1 Phase Nonreversing

208-240 Volt/60 Hertz/3 Phase and 460-480 Volt/60 Hertz/3 Phase Reversing and Nonreversing

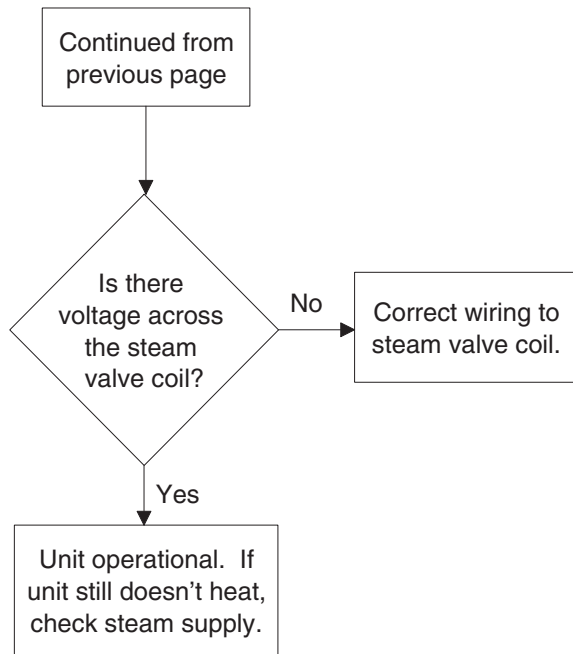

35. OM Models: No Start With Cycle Selected, Start Button Pressed and Door Closed

120 Volt/60 Hertz/1 Phase CG & CSH Nonreversing; 208-240 Volt/60 Hertz/1 or 3 Phase CSH Nonreversing; 208-240 Volt/60 Hertz/3 Phase CE Nonreversing; 460-480 Volt/60 Hertz/3 Phase CG, CE and CSH Nonreversing

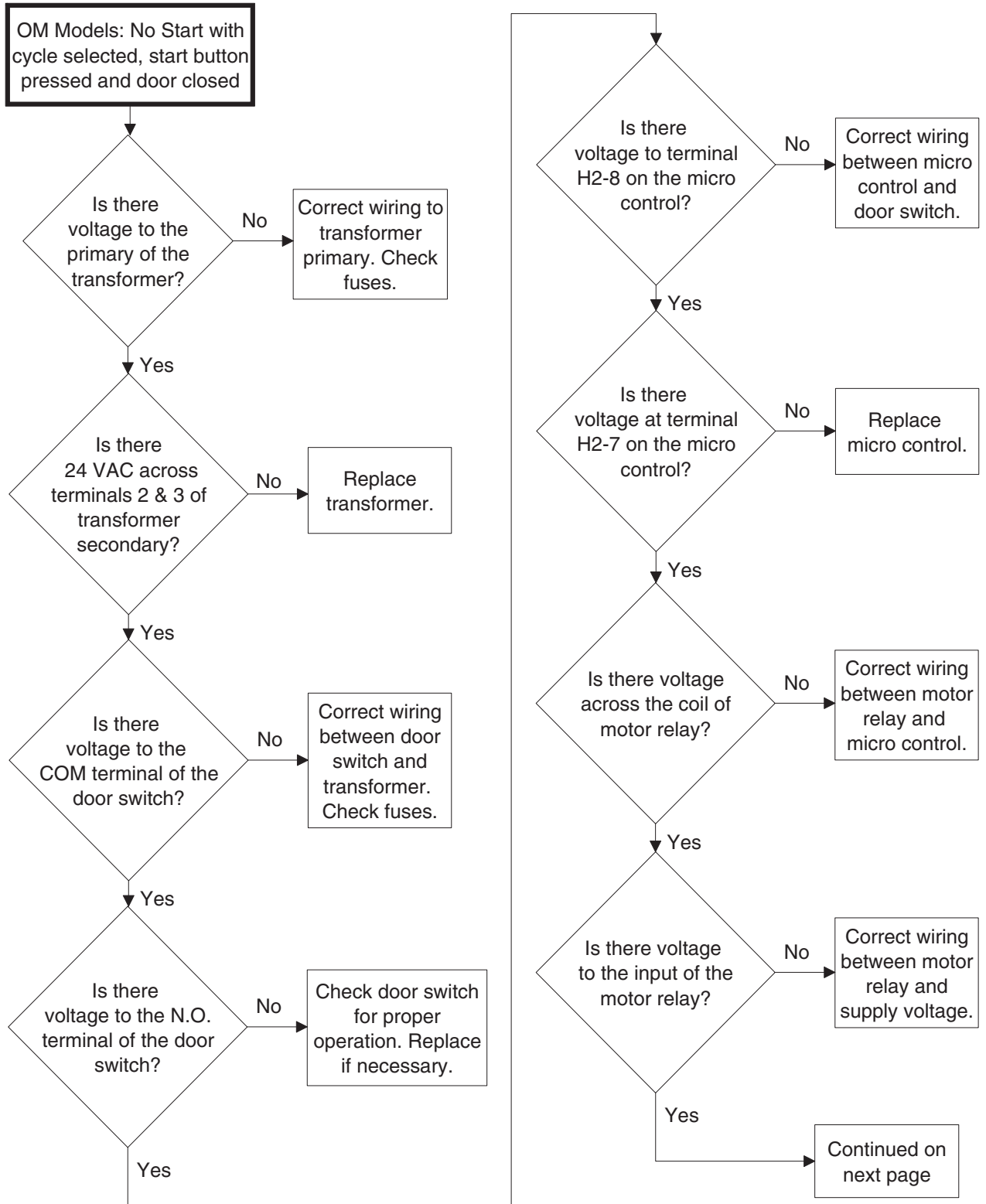

TMB2162S-a

35. OM Models: No Start With Cycle Selected, Start Button Pressed and Door Closed (continued)

120 Volt/60 Hertz/1 Phase CG & CSH Nonreversing; 208-240 Volt/60 Hertz/1 or 3 Phase CSH Nonreversing; 208-240 Volt/60 Hertz/3 Phase CE Nonreversing; 460-480 Volt/60 Hertz/3 Phase CG, CE and CSH Nonreversing

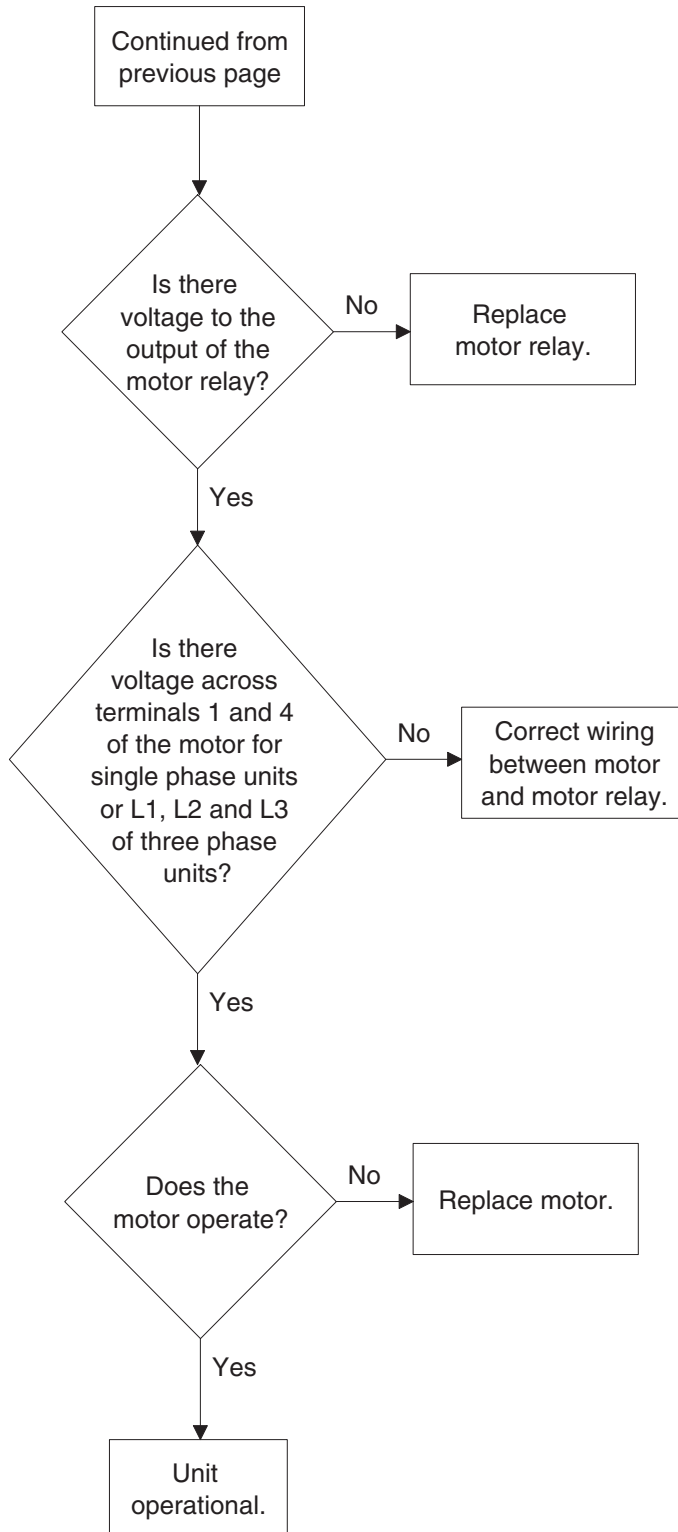

TMB2162S-b

36. OM Models: No Display After Selecting One Of The ON/SELECT Keys

120 Volt/60 Hertz/1 Phase CG and CSH Nonreversing; 208-240 Volt/60 Hertz/1 Phase CG and CSH Nonreversing; 208-240 Volt/60 Hertz/3 Phase CG and CSH Reversing/Nonreversing; 208-240 Volt/60 Hertz/3 Phase CE Reversing/Nonreversing; 460-480 Volt/60 Hertz/3 Phase CG, CE and CSH Reversing/Nonreversing

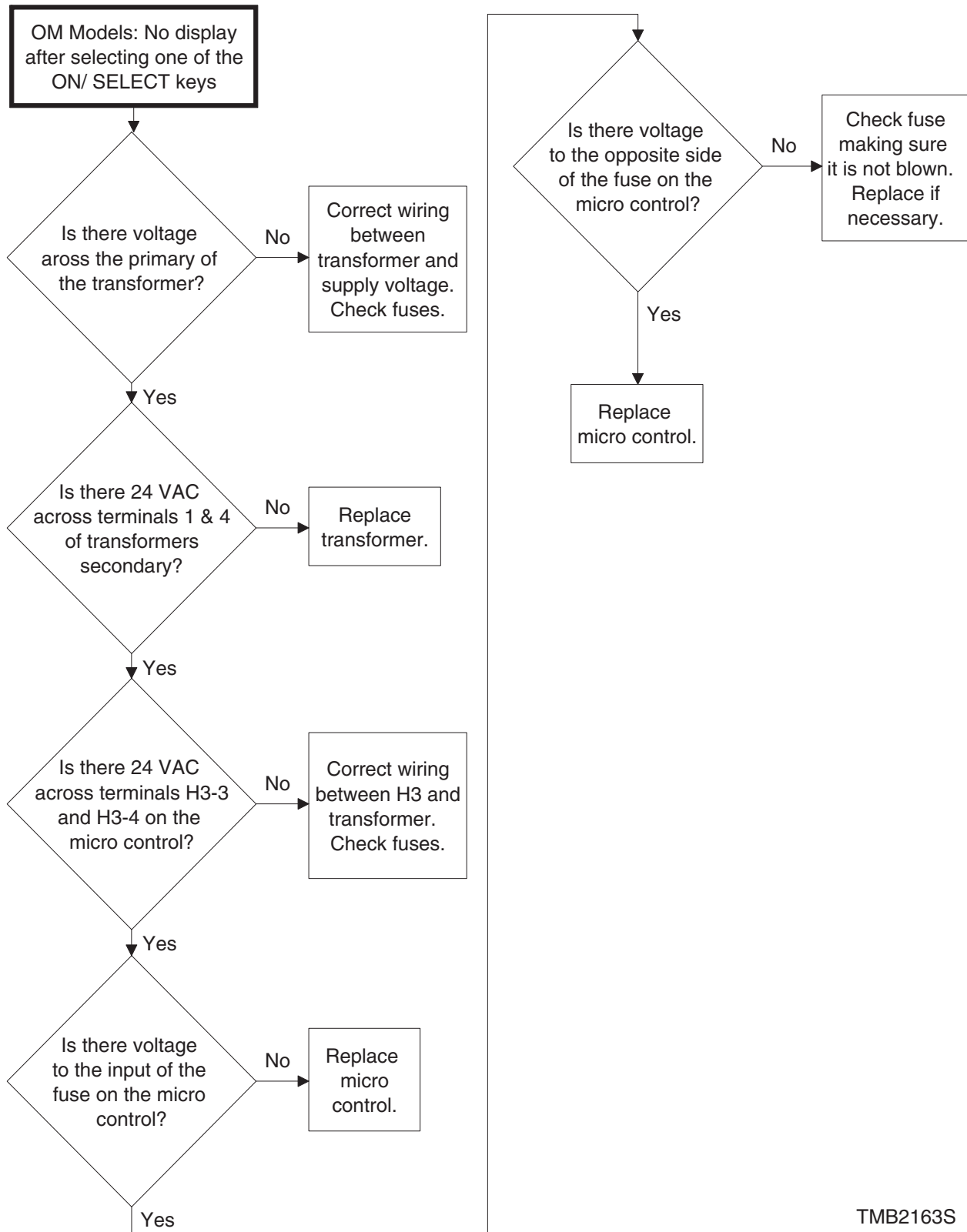

TMB2163S

37. CE OM Models: No Heat With Cycle Selected, Unit Running and Calling For Heat

208-240 Volt/60 Hertz/3 Phase and 460-480 Volt/60 Hertz/3 Phase Reversing and Nonreversing

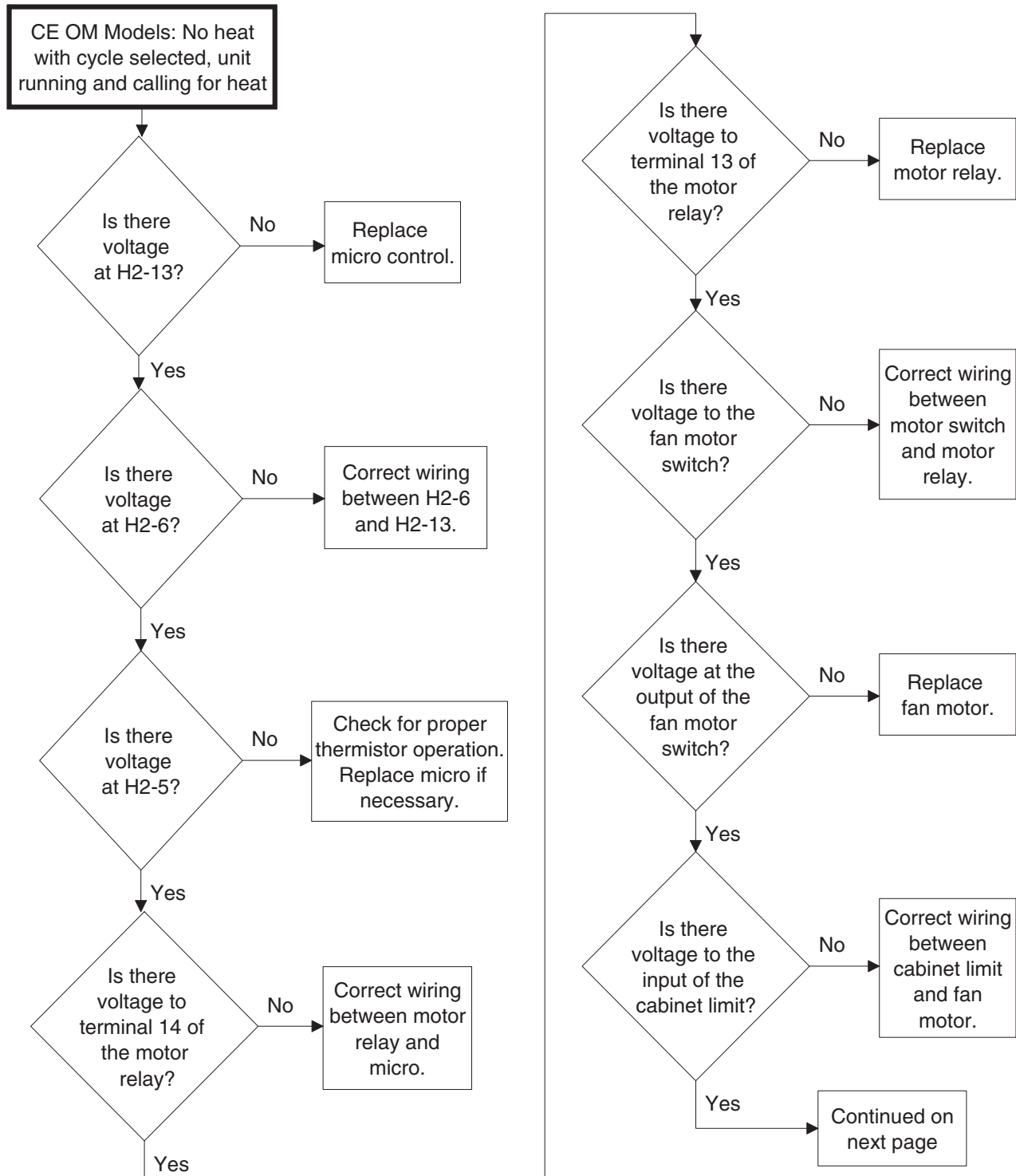

TMB2164S-a

37. CE OM Models: No Heat With Cycle Selected, Unit Running and Calling For Heat (continued)

208-240 Volt/60 Hertz/3 Phase and 460-480 Volt/60 Hertz/3 Phase Reversing and Nonreversing

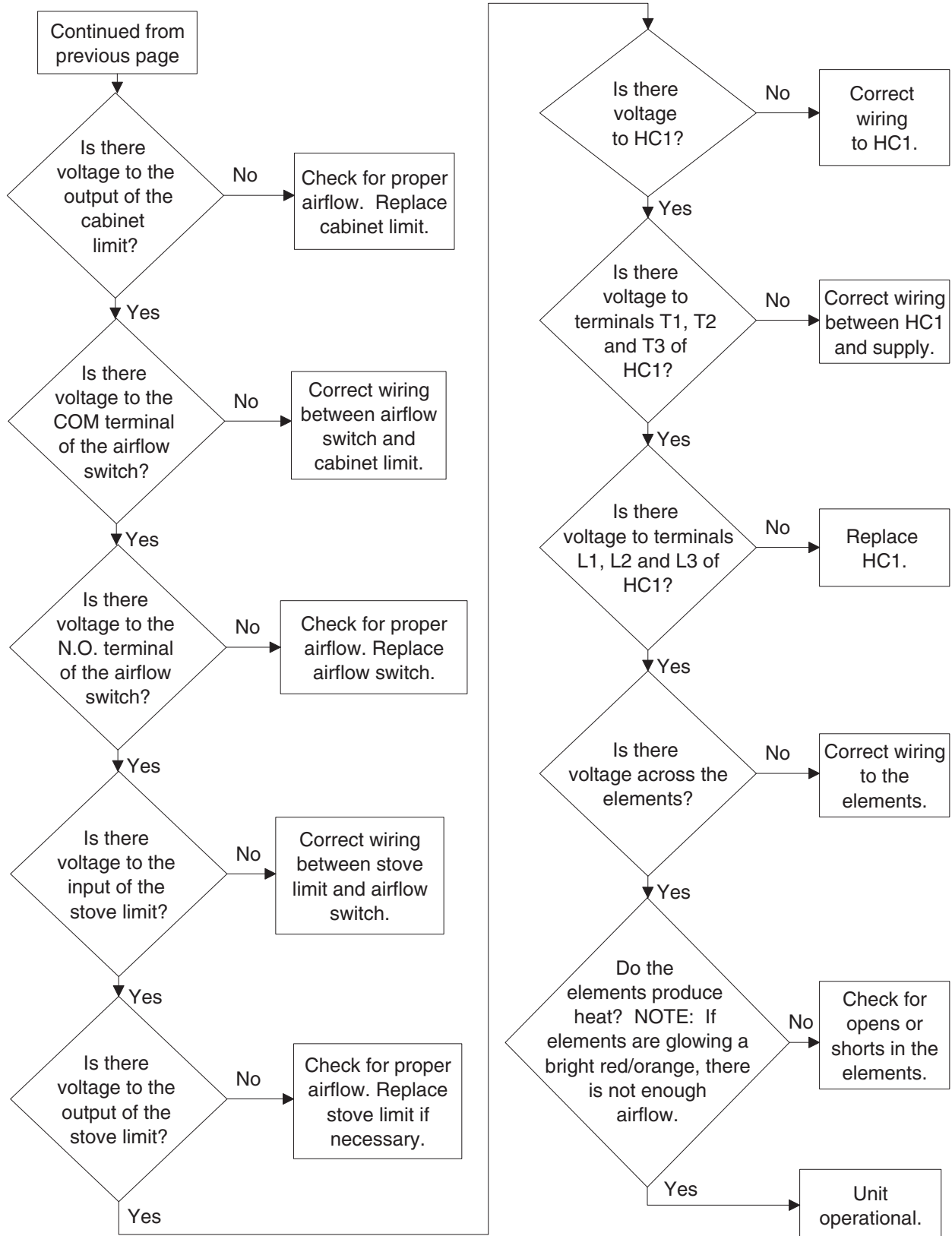

TMB2164S-b

38. CG OM Models: No Heat With Cycle Selected, Unit Running and Calling For Heat

120 Volt/60 Hertz/1 Phase and 208-240 Volt/60 Hertz/1 Phase Nonreversing

208-240 Volt/60 Hertz/3 Phase and 460-480 Volt/60 Hertz/3 Phase Reversing and Nonreversing

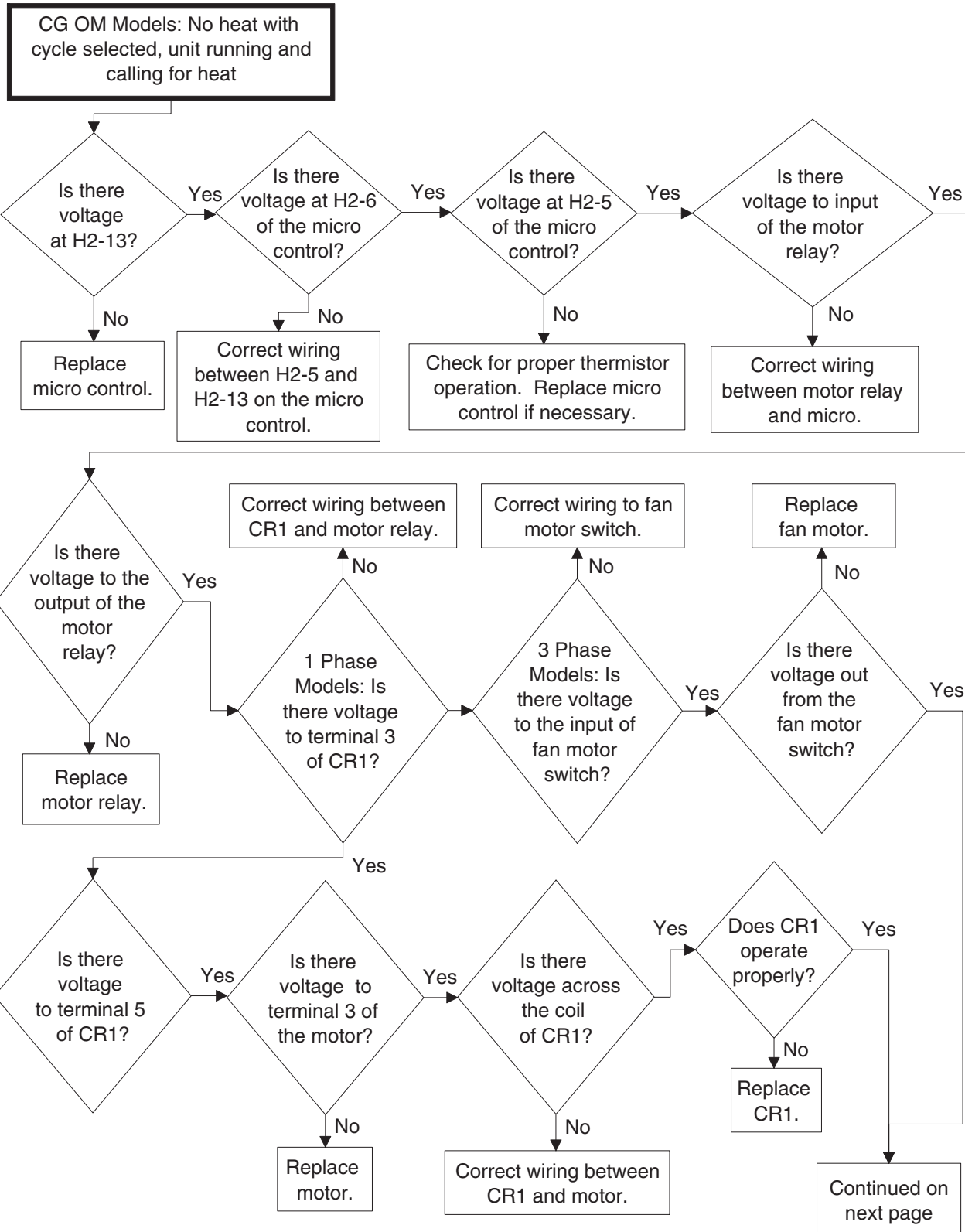

TMB2165S-a

38. CG OM Models: No Heat With Cycle Selected, Unit Running and Calling For Heat (continued)

120 Volt/60 Hertz/1 Phase and 208-240 Volt/60 Hertz/1 Phase Nonreversing

208-240 Volt/60 Hertz/3 Phase and 460-480 Volt/60 Hertz/3 Phase Reversing and Nonreversing

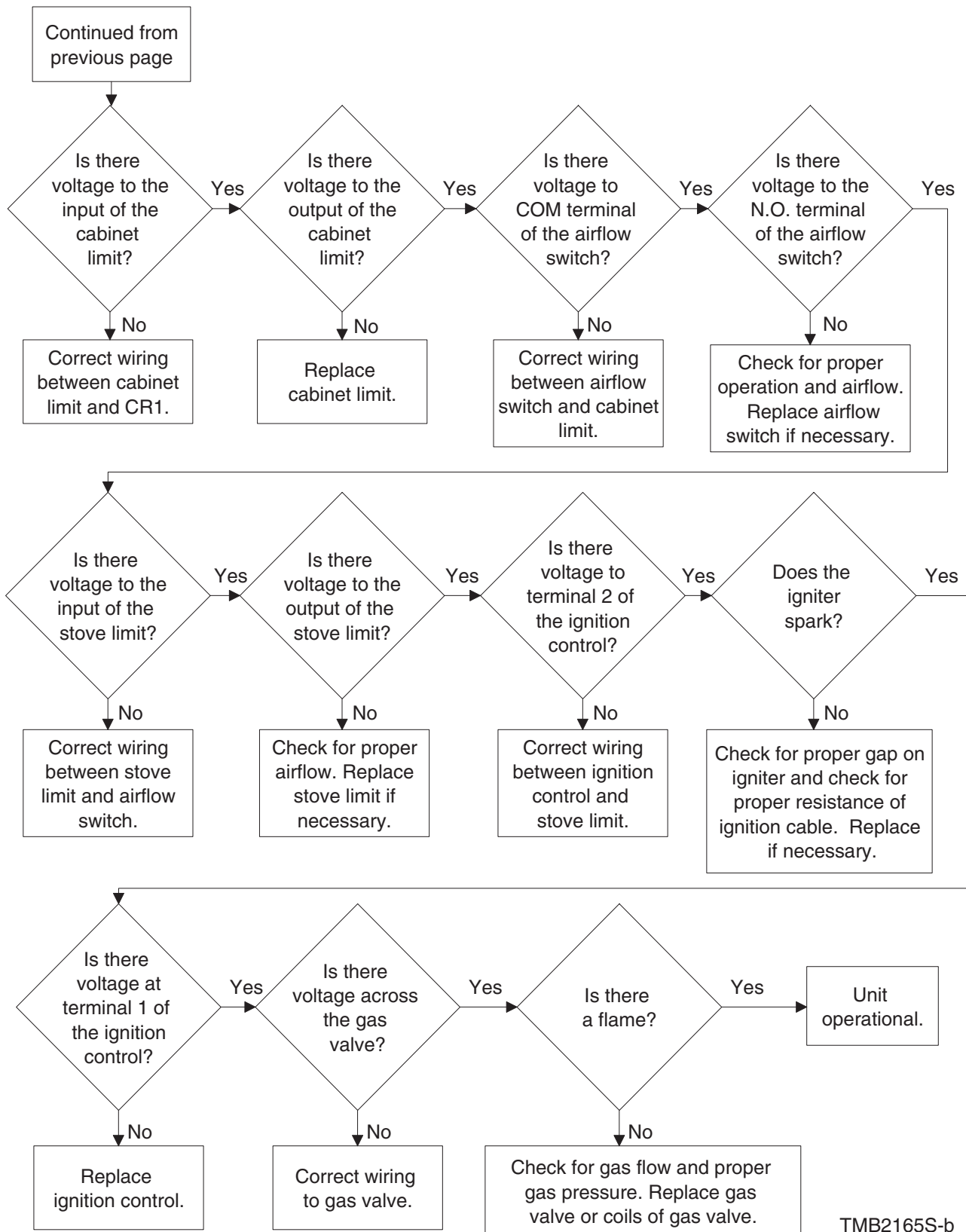

TMB2165S-b

39. OM Models: No Fan Motor Rotation With Cycle Selected and Start Pressed

208-240 Volt/60 Hertz/3 Phase and 480 Volt/60 Hertz/3 Phase CE Reversing Models; 208-240 Volt/60 Hertz/3 Phase and 460-480 Volt/60 Hertz/3 Phase CG Reversing and CSH Models

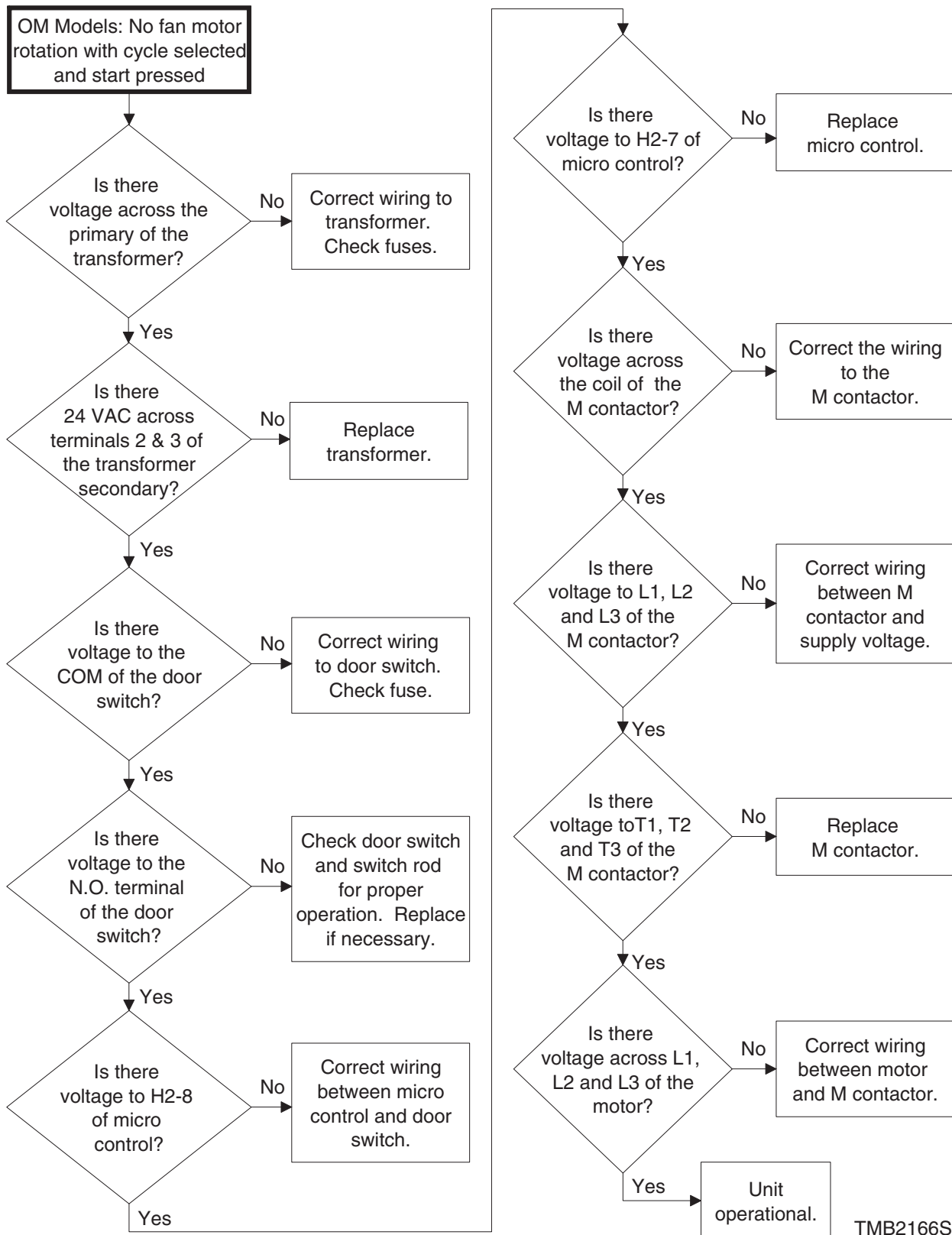

TMB2166S

40. MM Models: Fan Motor Does Not Run With Door Closed, Cycle Selected and Start Button Pressed

208-240 Volt/60 Hertz/3 Phase Gas and Steam Reversing and Nonreversing; 480 Volt/60 Hertz/3 Phase Gas Nonreversing; 480 Volt/60 Hertz/3 Phase Steam Reversing

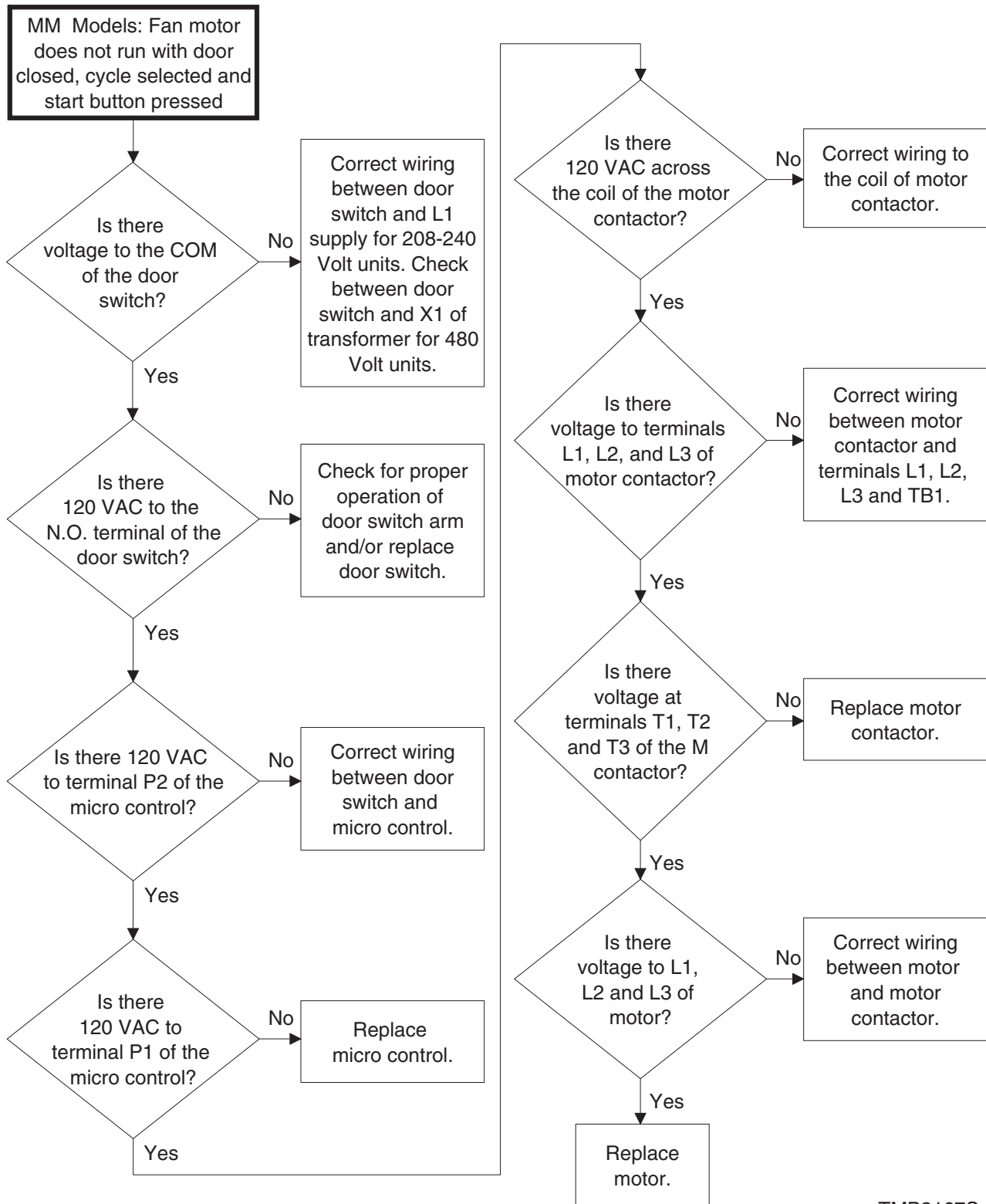

TMB2167S

NOTE: Make sure fuse on x1 of transformer is operational (240 Volt and 480 Volt/60 Hertz/3 Phase units).

41. MM Models: Cylinder Motor Does Not Run or Reverse With Door Closed, Cycle Selected and Start Button Pressed In Reversing Mode or Nonreversing Mode

480 Volt/60 Hertz/3 Phase Steam Reversing and 208-240 Volt/60 Hertz/3 Phase Gas and Steam Reversing Models

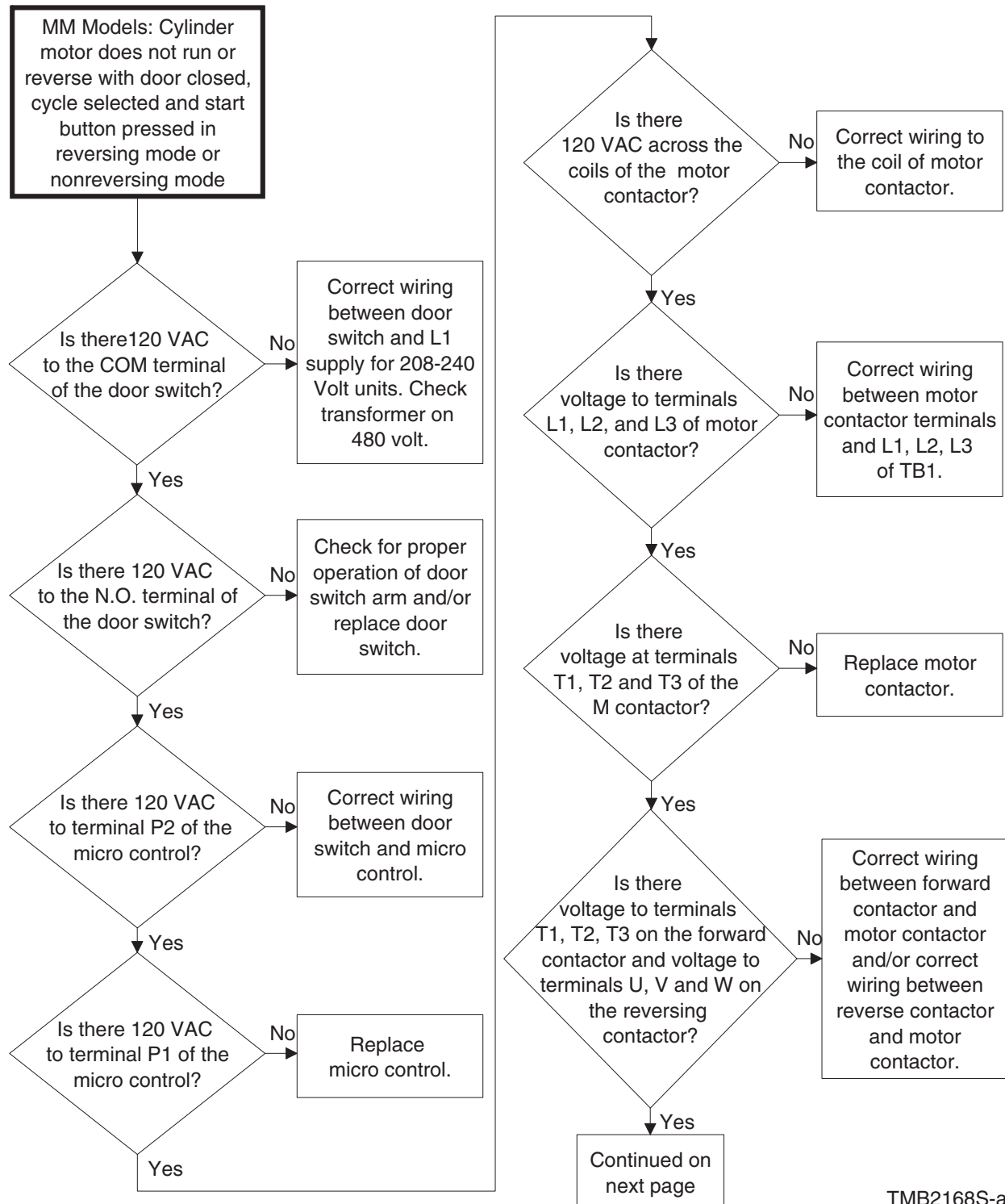

TMB2168S-a

NOTE: If the unit will not reverse when reversing is selected, check for proper operation and wiring of reversing switch. Replace if necessary.

41. MM Models: Cylinder Motor Does Not Run or Reverse With Door Closed, Cycle Selected and Start Button Pressed In Reversing Mode or Nonreversing Mode (continued)
 480 Volt/60 Hertz/3 Phase Steam Reversing and 208-240 Volt/60 Hertz/3 Phase Gas and Steam Reversing Models

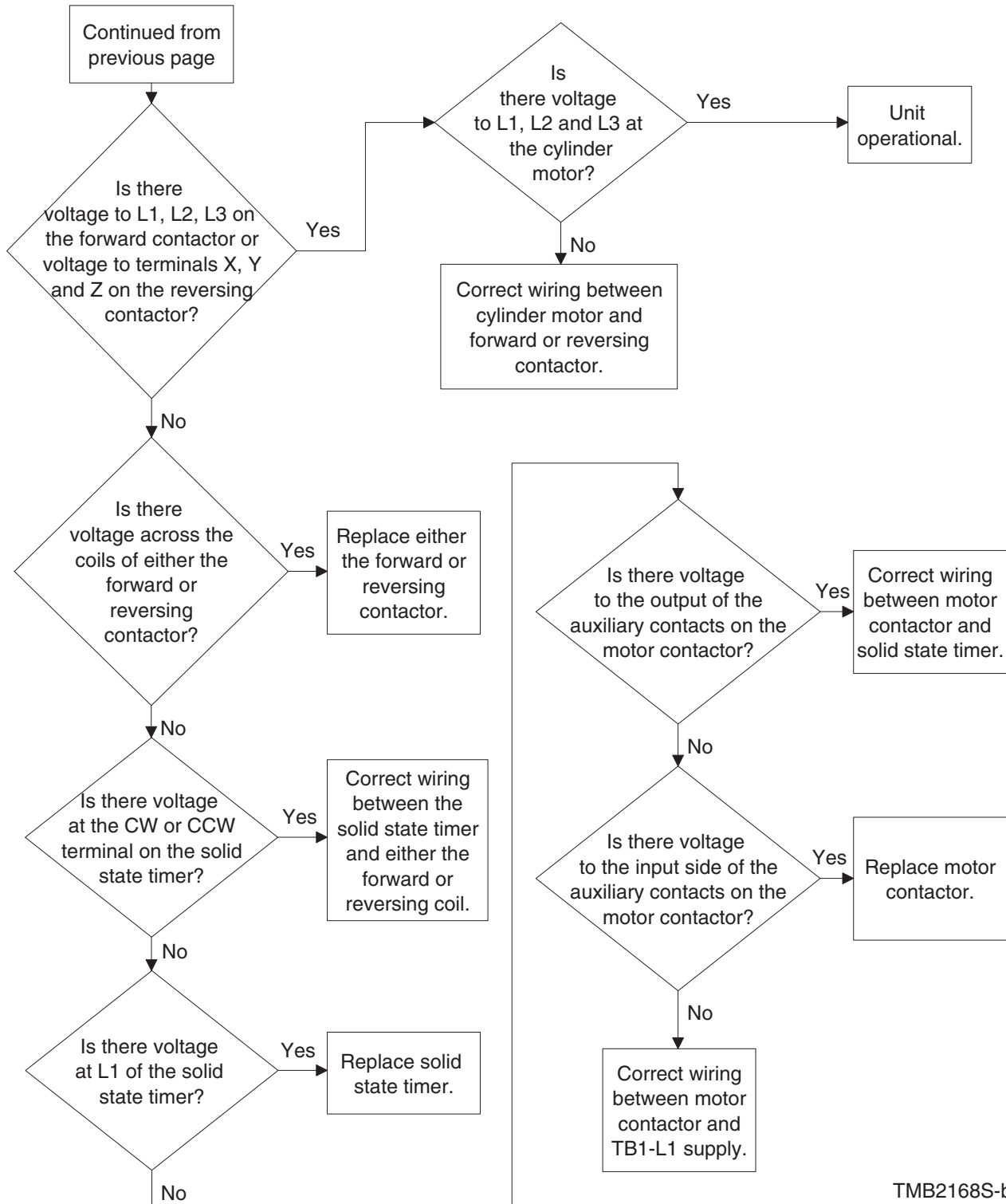

TMB2168S-b

NOTE: If the unit will not reverse when reversing is selected, check for proper operation and wiring of reversing switch. Replace if necessary.

42. MM Models: No Heat With Cycle Selected, Unit Running and Calling For Heat

120 Volt/60 Hertz/1 Phase and 208-240 Volt/60 Hertz/1 Phase Gas and Steam Nonreversing
 208-240 Volt/60 Hertz/3 Phase and 480 Volt/60 Hertz/3 Phase Steam Reversing and Nonreversing

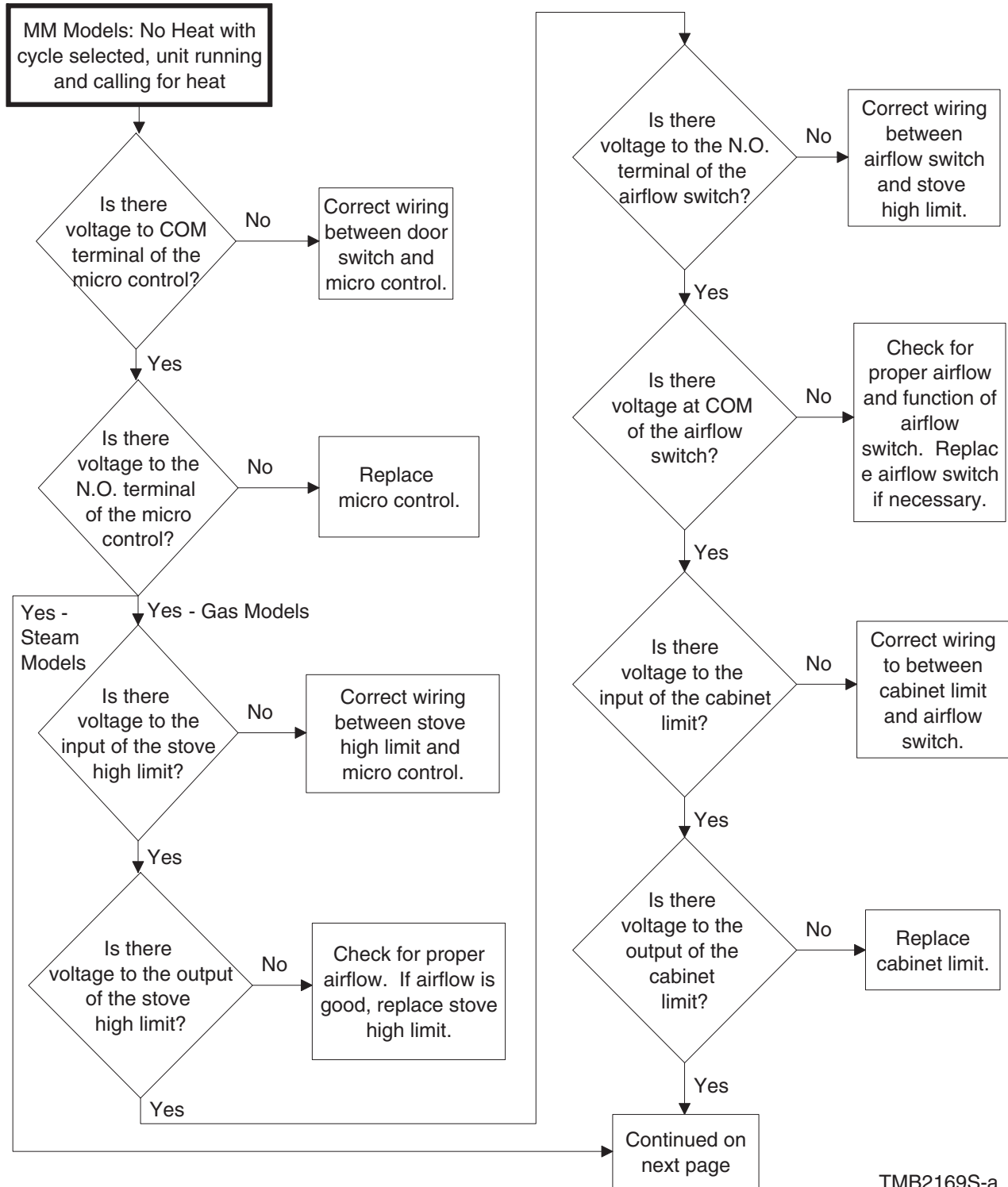

TMB2169S-a

42. MM Models: No Heat With Cycle Selected, Unit Running and Calling For Heat (continued)

120 Volt/60 Hertz/1 Phase and 208-240 Volt/60 Hertz/1 Phase Gas and Steam Nonreversing
 208-240 Volt/60 Hertz/3 Phase and 480 Volt/60 Hertz/3 Phase Steam Reversing and Nonreversing

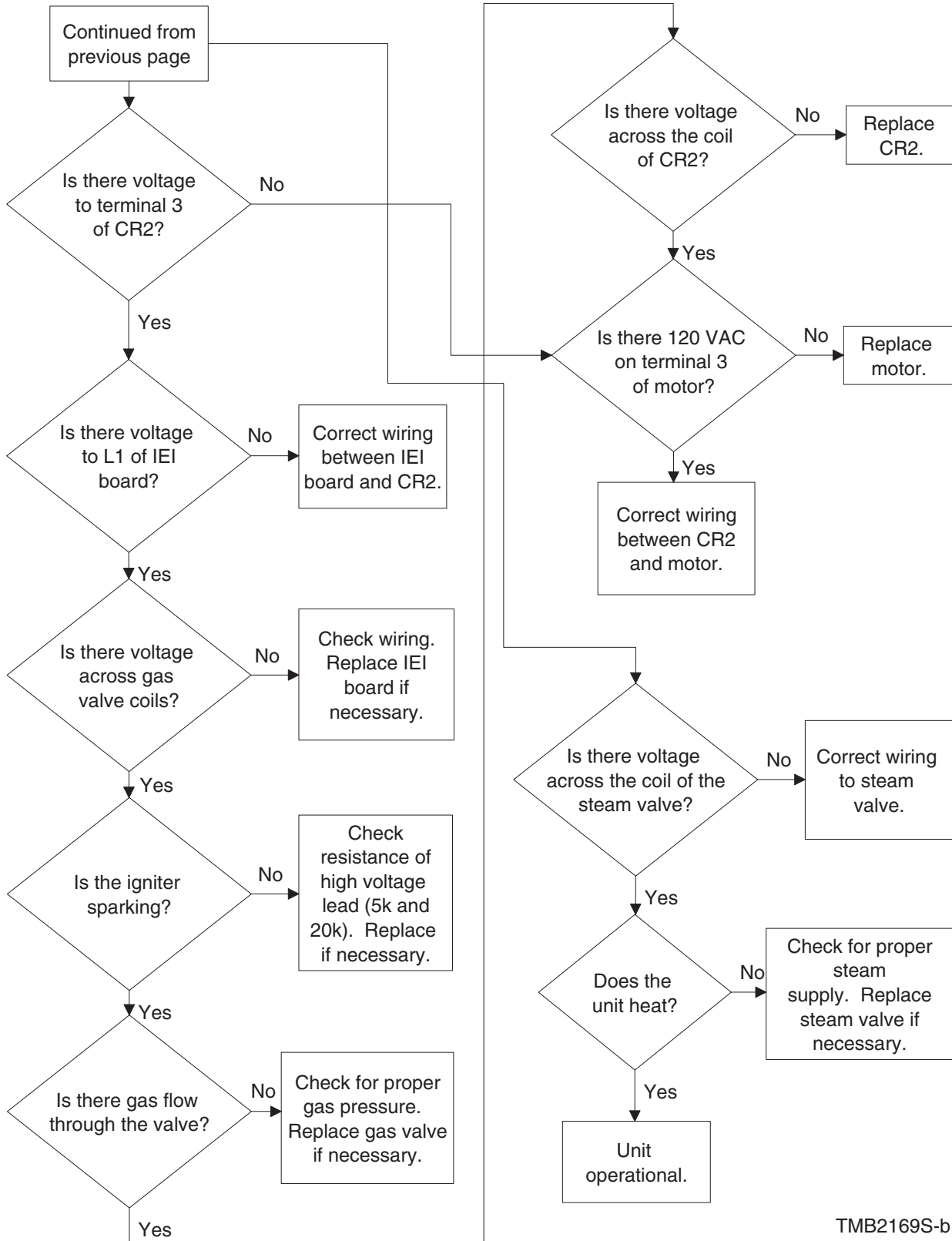

TMB2169S-b

43. MM Models: No Heat With Cycle Selected, Unit Running and Calling For Heat

208-240 Volt/60 Hertz/3 Phase Gas Reversing

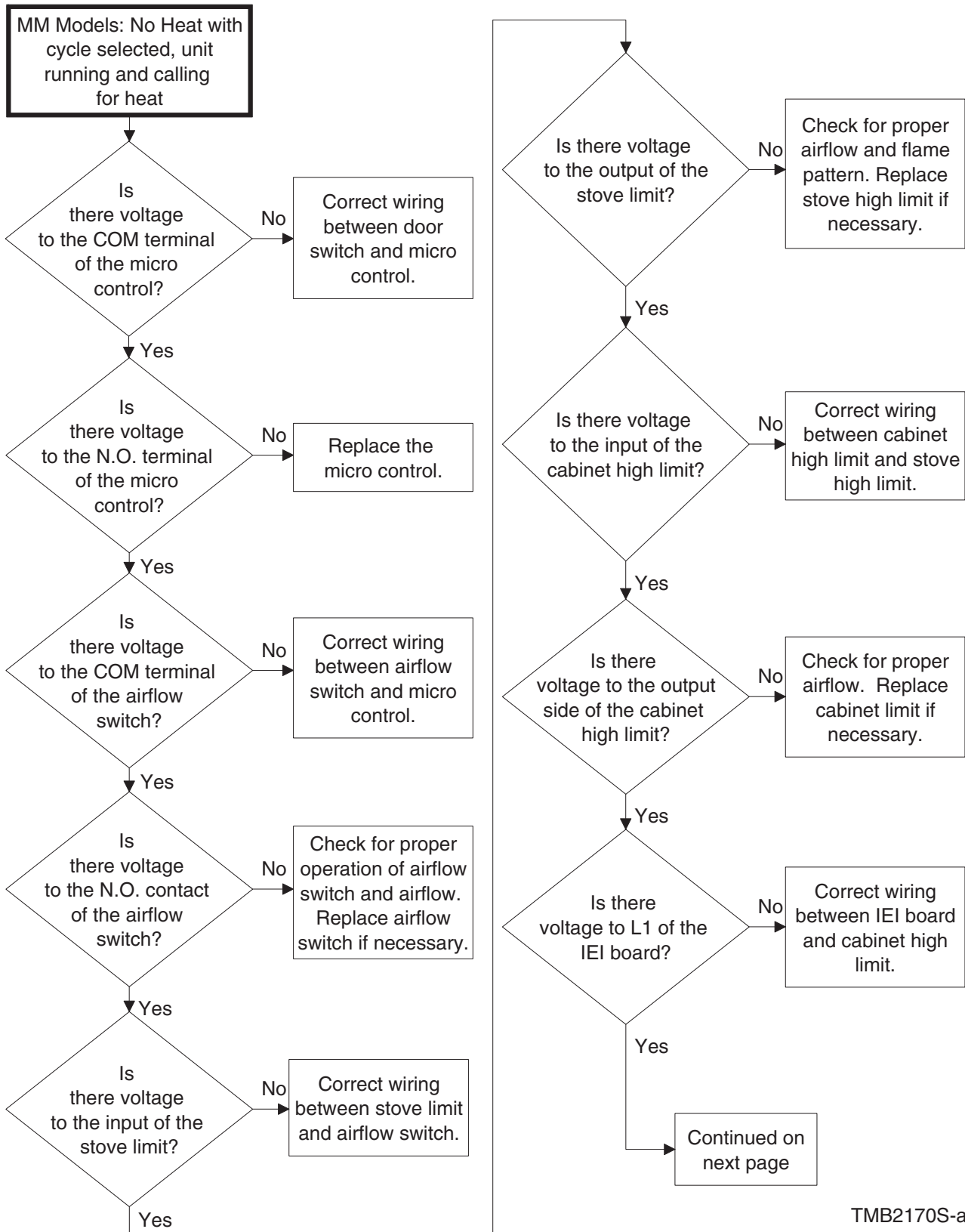

TMB2170S-a

43. MM Models: No Heat With Cycle Selected, Unit Running and Calling For Heat (continued)

208-240 Volt/60 Hertz/3 Phase Gas Reversing

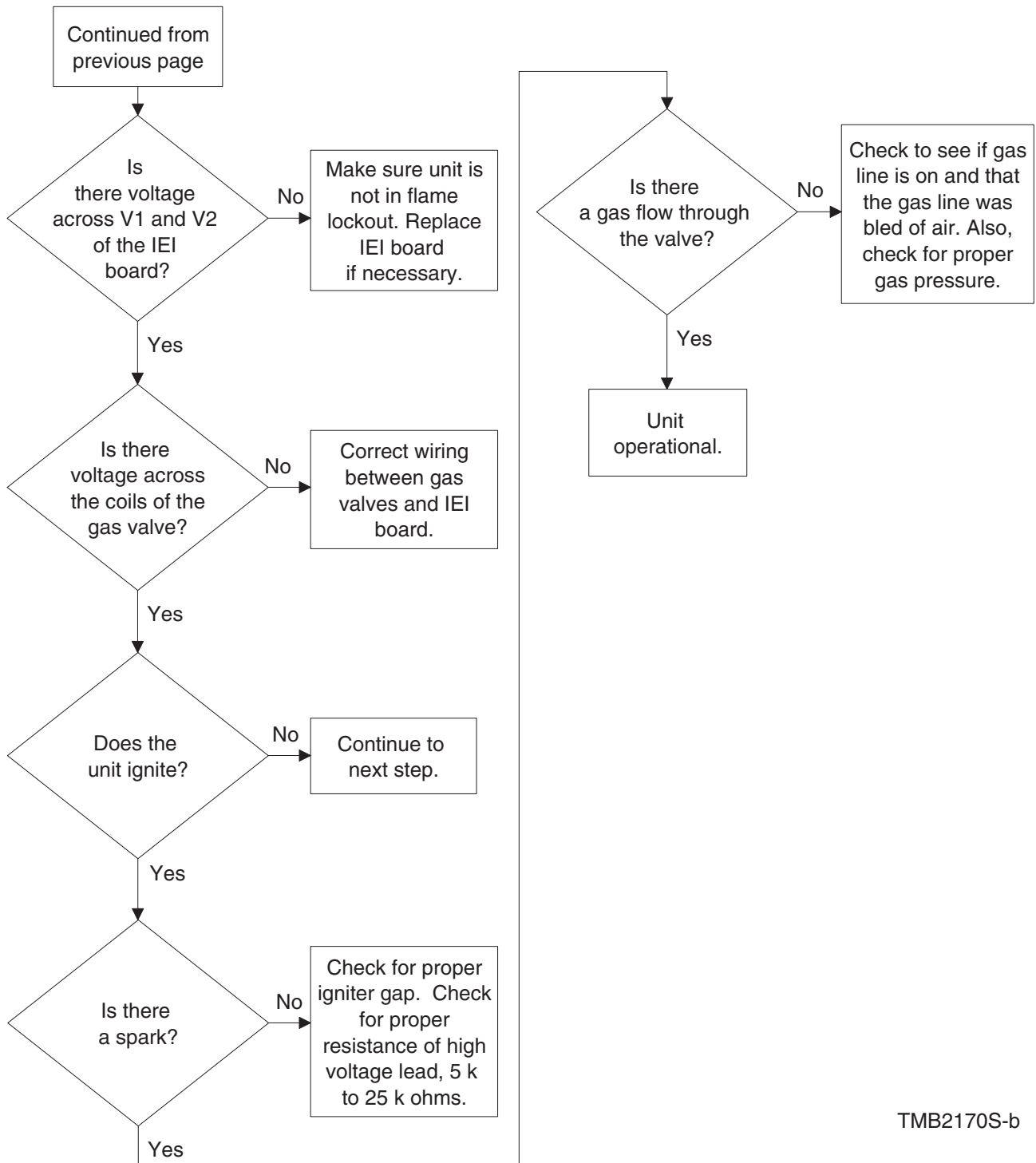

TMB2170S-b

44. OM Reversing Models: No Cylinder Rotation or Reversing Capabilities

208-240 Volt/60 Hertz/3 Phase and 480 Volt/60 Hertz/3 Phase CE Models

208-240 Volt/60 Hertz/3 Phase and 460-480 Volt/60 Hertz/3 Phase CG and CSH Models

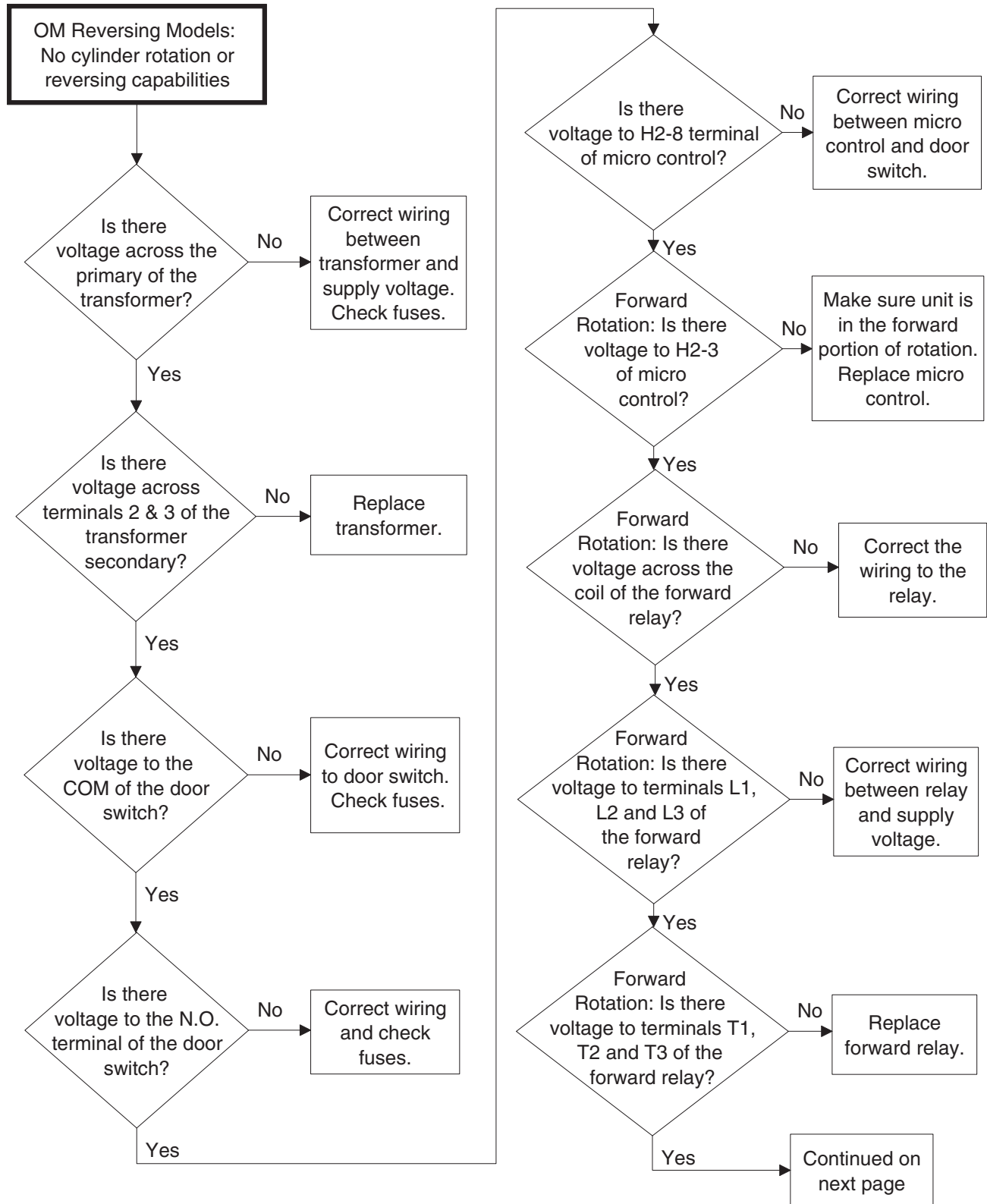

TMB2171S-a

44. OM Reversing Models: No Cylinder Rotation or Reversing Capabilities (continued)

208-240 Volt/60 Hertz/3 Phase and 480 Volt/60 Hertz/3 Phase CE Models

208-240 Volt/60 Hertz/3 Phase and 460-480 Volt/60 Hertz/3 Phase CG and CSH Models

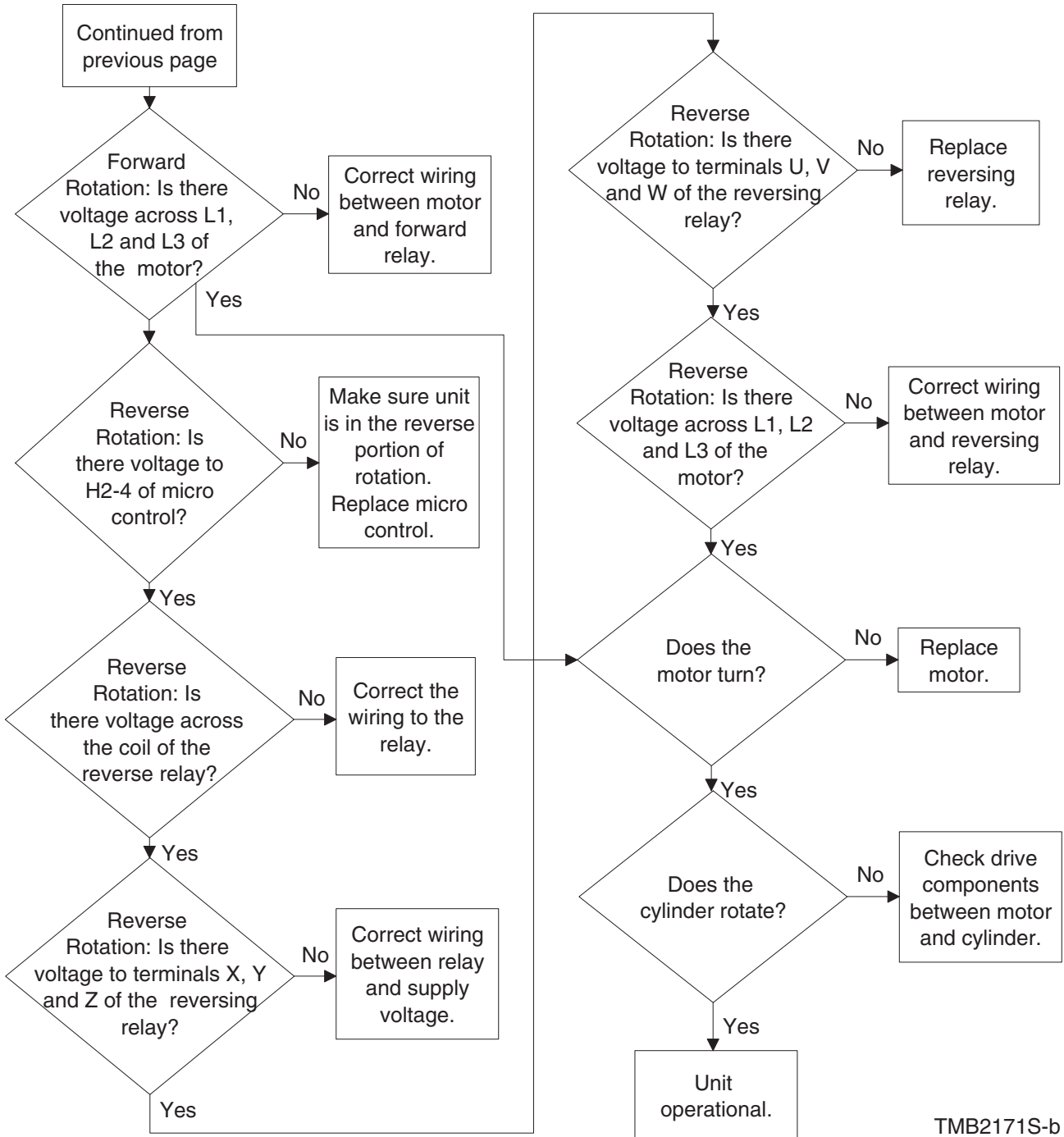

TMB2171S-b

45. MM Models: No Display After Pressing the ON/SELECT Keys

120 Volt/60 Hertz/1 Phase and 208-240 Volt/60 Hertz/1 Phase Gas and Steam Nonreversing
 208-240 Volt/60 Hertz/3 Phase and 480 Volt/60 Hertz/3 Phase Gas and Steam Reversing/
 Nonreversing

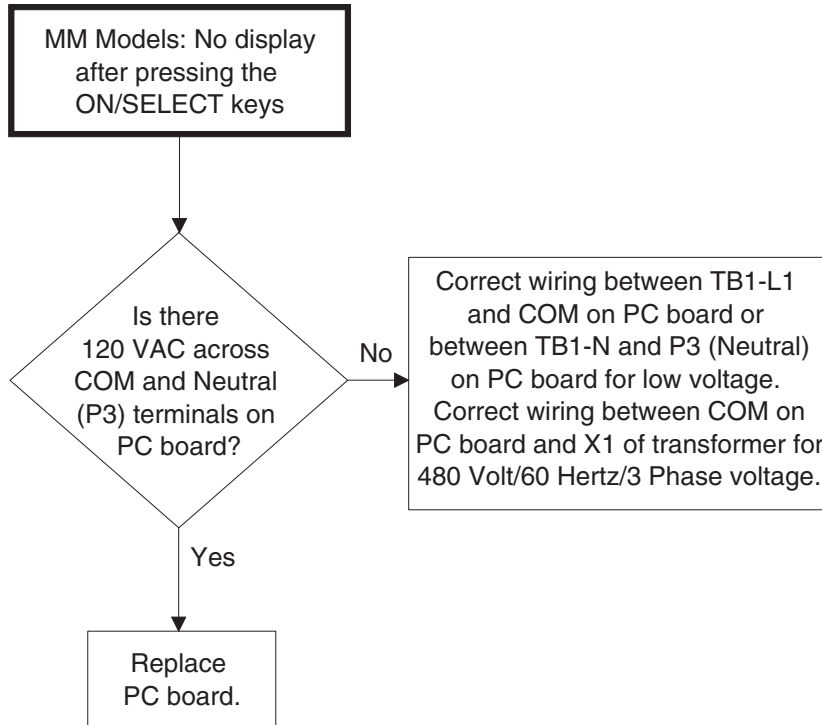

TMB2172S

NOTE: Make sure fuse on x1 line of transformer is operational. Used for 480 Volt/60 Hertz/3 Phase voltage.

NOTE: If unable to change settings, the keyboard has been manually locked out. To lock or unlock, press and hold the START pad and press TIME.

46. MM Models: Motor Does Not Run With Door Closed, Cycle Selected and Start Button Pressed

208-240 Volt/60 Hertz/3 Phase Gas and Steam Reversing and Nonreversing; 480 Volt/60 Hertz/3 Phase Gas Nonreversing; 480 Volt/60 Hertz/3 Phase Steam Reversing

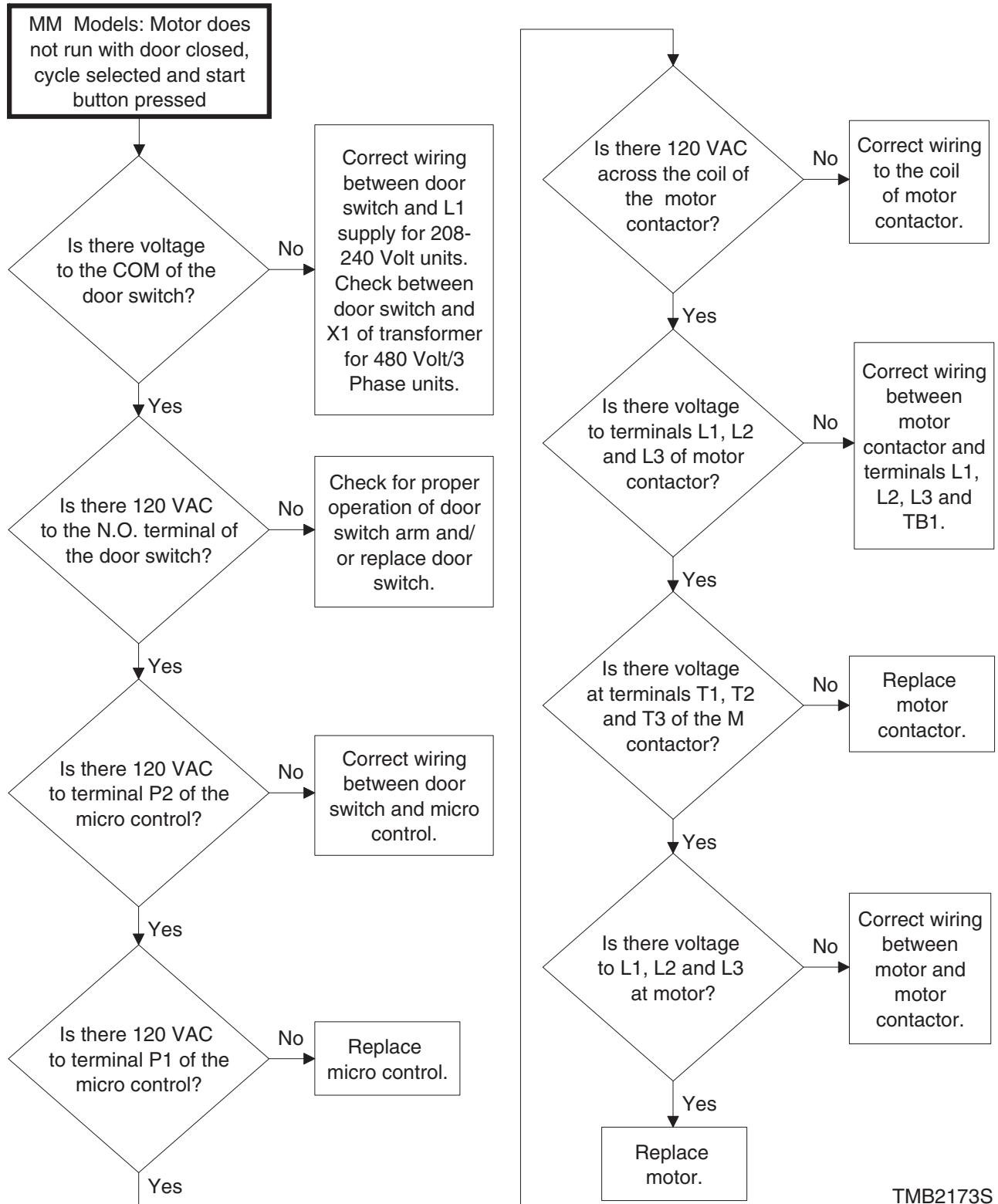

TMB2173S

NOTE: Make sure fuse on x1 of transformer is operational (480 Volt/60 Hertz/3 Phase units).

47. MM Models: Cylinder Motor Does Not Run or Reverse With Door Closed, Cycle Selected and Start Button Pressed In Reversing Mode or Nonreversing Mode

208-240 Volt/60 Hertz/3 Phase Gas and Steam Reversing and 480 Volt/60 Hertz/3 Phase Steam Reversing Models

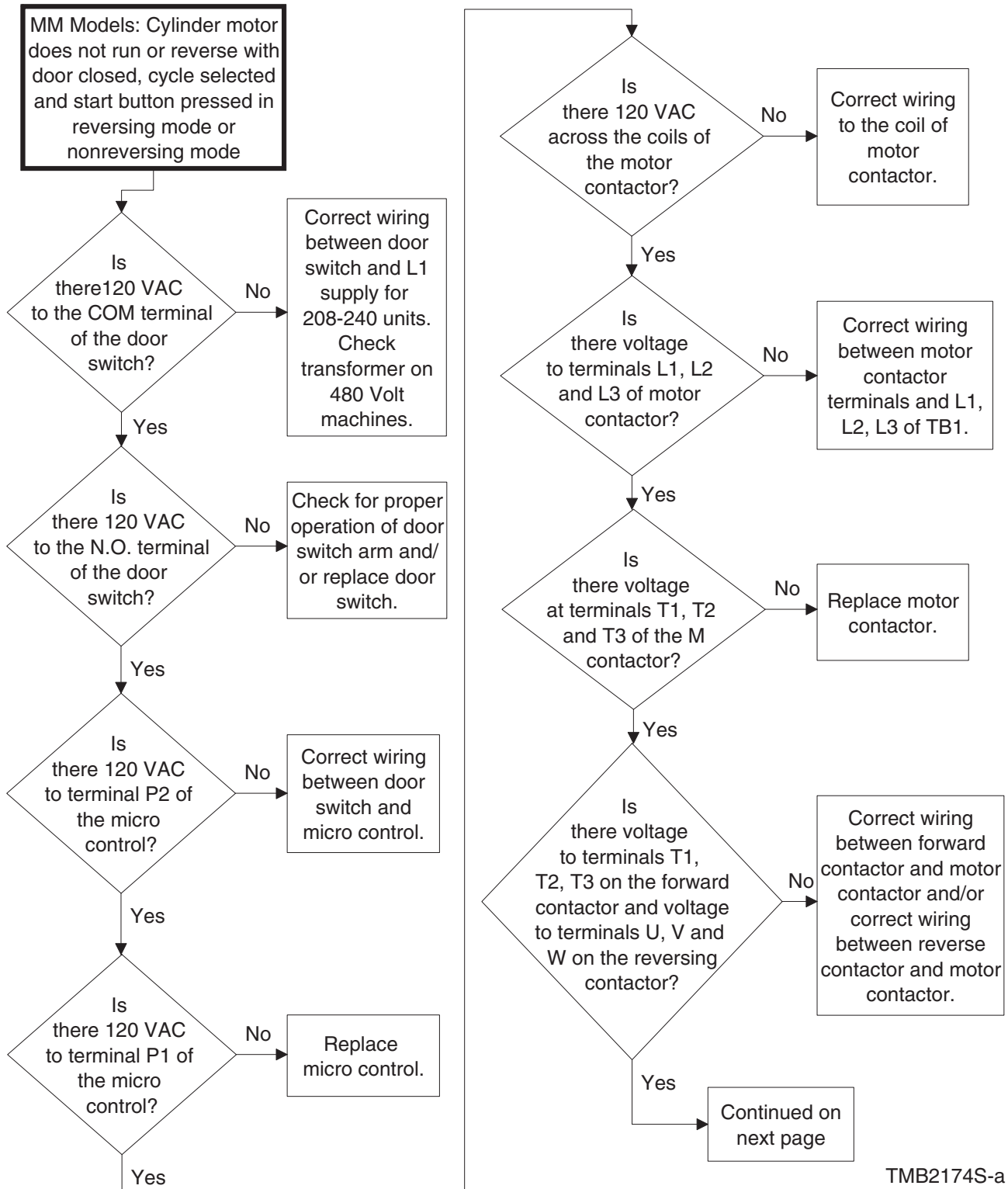

TMB2174S-a

NOTE: If unit will not reverse when reversing is selected, check for proper operation and wiring of reversing switch. Replace if necessary.

47. MM Models: Cylinder Motor Does Not Run or Reverse With Door Closed, Cycle Selected and Start Button Pressed In Reversing Mode or Nonreversing Mode (continued)
 208-240 Volt/60 Hertz/3 Phase Gas and Steam Reversing and 480 Volt/60 Hertz/3 Phase Steam Reversing Models

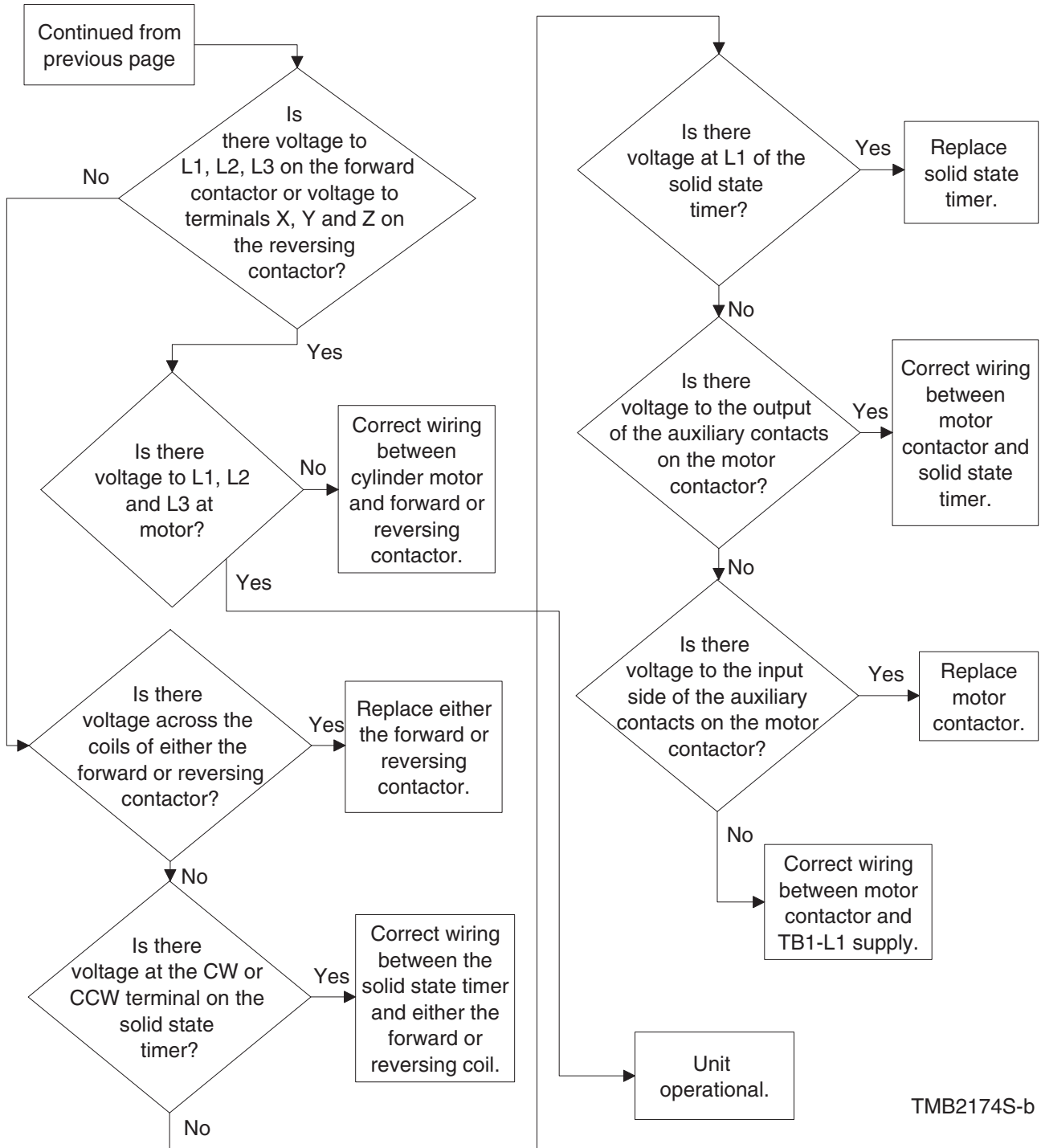

TMB2174S-b

NOTE: If unit will not reverse when reversing is selected, check for proper operation and wiring of reversing switch. Replace if necessary.

48. MM Nonreversing Models: Motor Does Not Run With Door Closed, Cycle Selected and Start Button Pressed

120 Volt/60 Hertz/1 Phase Gas and Steam; 208-240 Volt/60 Hertz/3 Phase Gas; 480 Volt/60 Hertz/3 Phase Steam

NOTE: Voltage checks referenced to are for neutral unless stated otherwise.

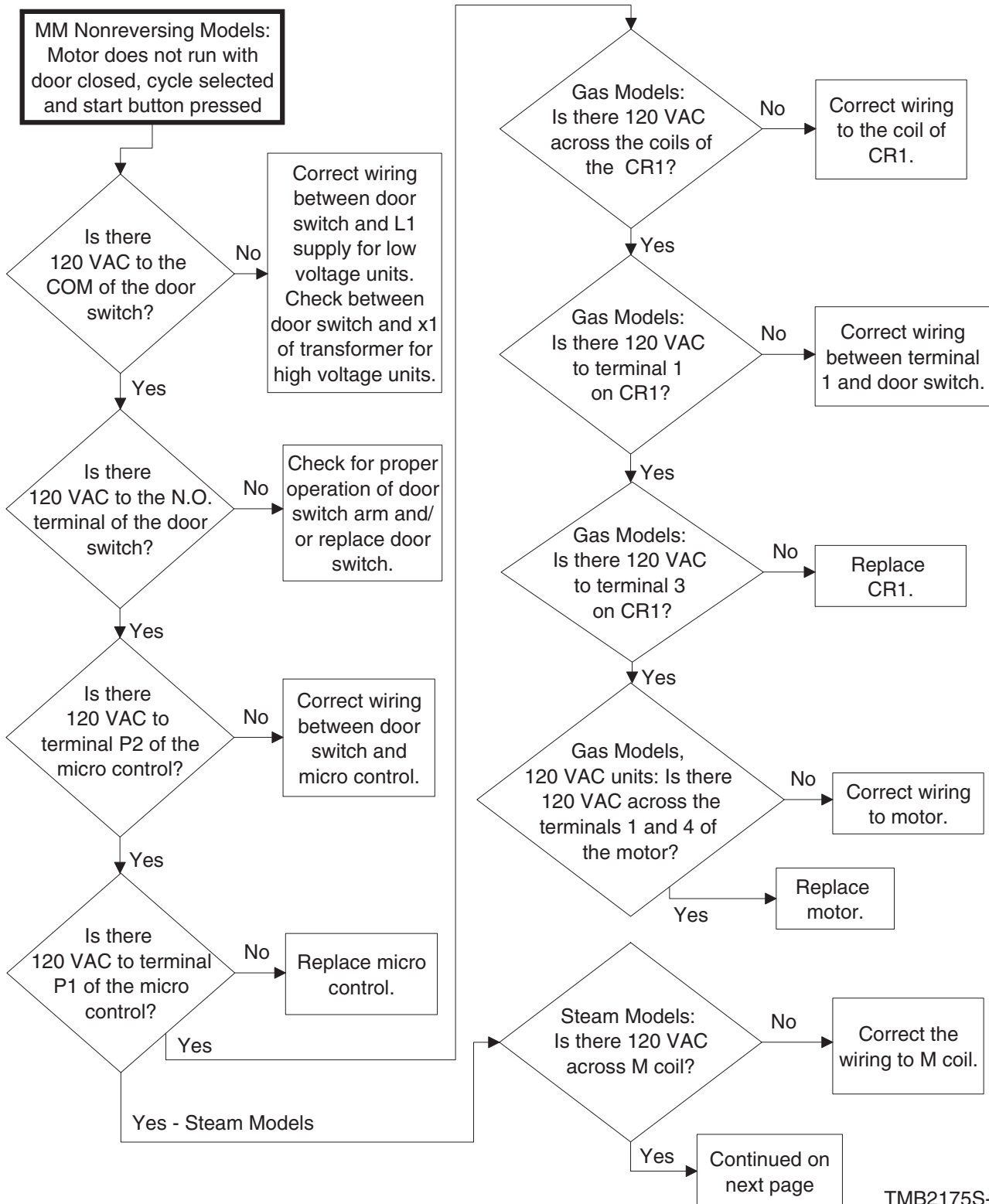

TMB2175S-a

48. MM Nonreversing Models: Motor Does Not Run With Door Closed, Cycle Selected and Start Button Pressed (continued)

120 Volt/60 Hertz/1 Phase Gas and Steam; 208-240 Volt/60 Hertz/3 Phase Gas; 480 Volt/60 Hertz/3 Phase Steam

NOTE: Voltage checks referenced to are for neutral unless stated otherwise.

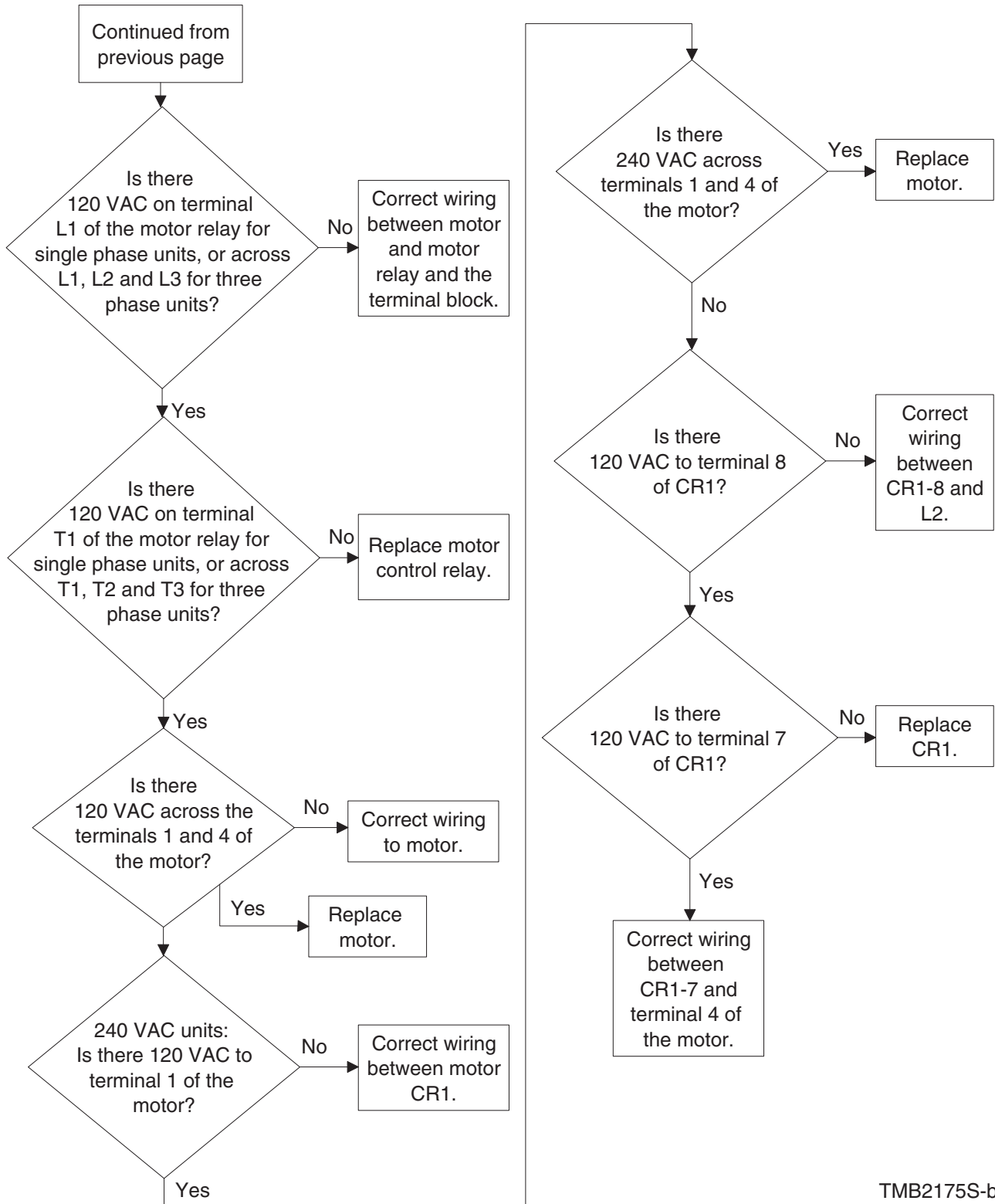

TMB2175S-b

49. CD Models: No Start With Vend Satisfied and Start Button Pushed

208-240 Volt/60 Hertz/3 Phase Gas Nonreversing

NOTE: All voltage checks are referenced to neutral unless stated otherwise.

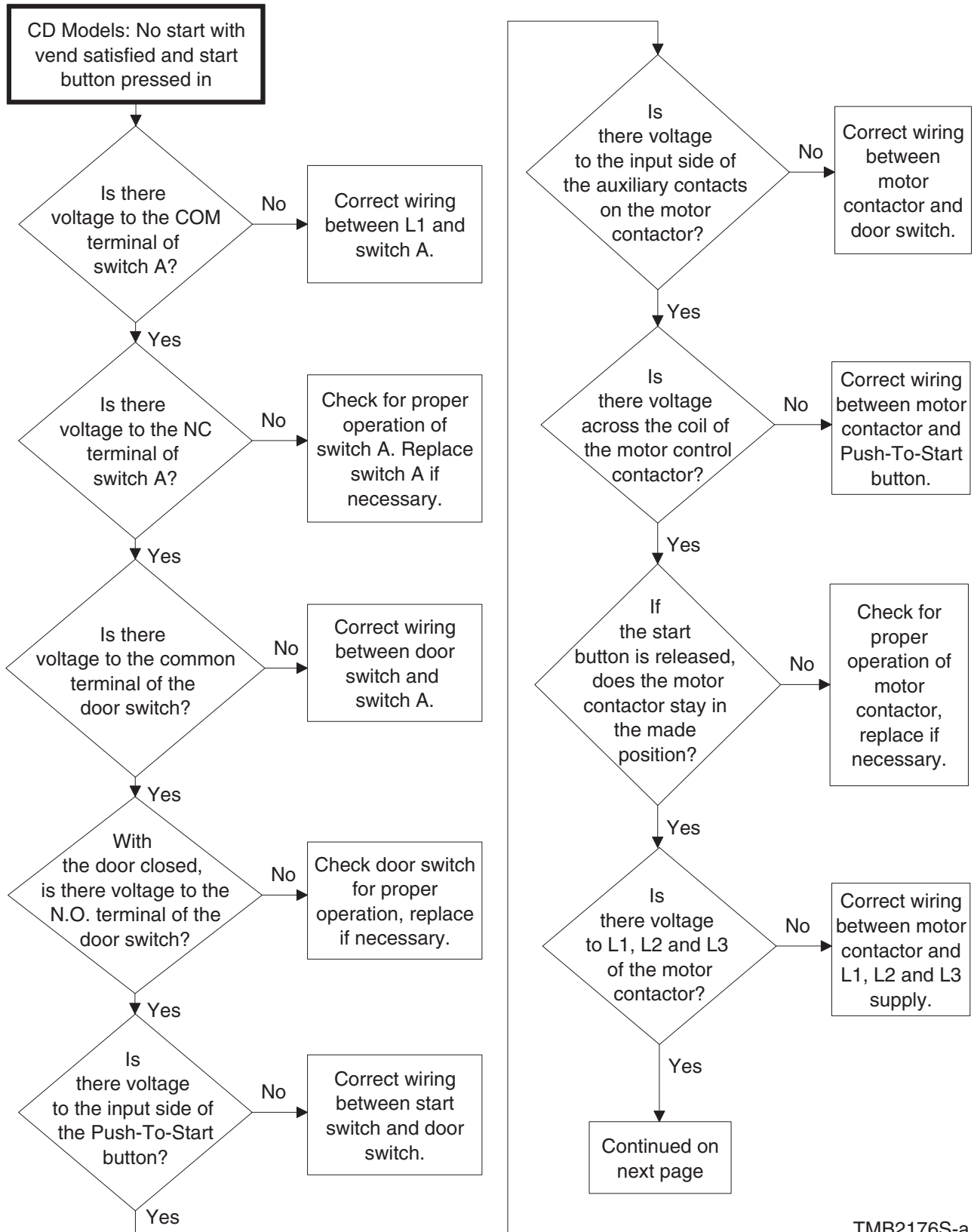

TMB2176S-a

49. CD Models: No Start With Vend Satisfied and Start Button Pushed (continued)

208-240 Volt/60 Hertz/3 Phase Gas Nonreversing

NOTE: All voltage checks are referenced to neutral unless stated otherwise.

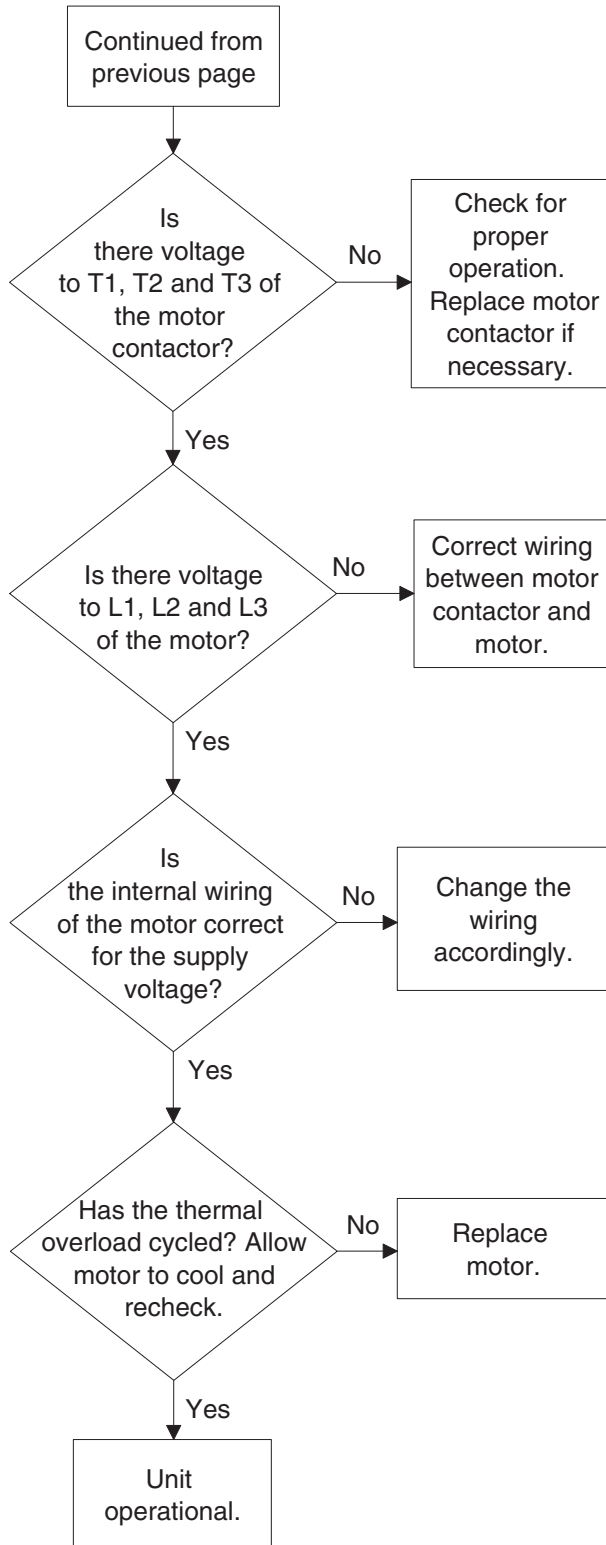

TMB2176S-b

50. CD Models: No Heat With Vend Satisfied and Unit Running 208-240 Volt/60 Hertz/3 Phase Gas Nonreversing

NOTE: All voltage checks are referenced to neutral unless stated otherwise.

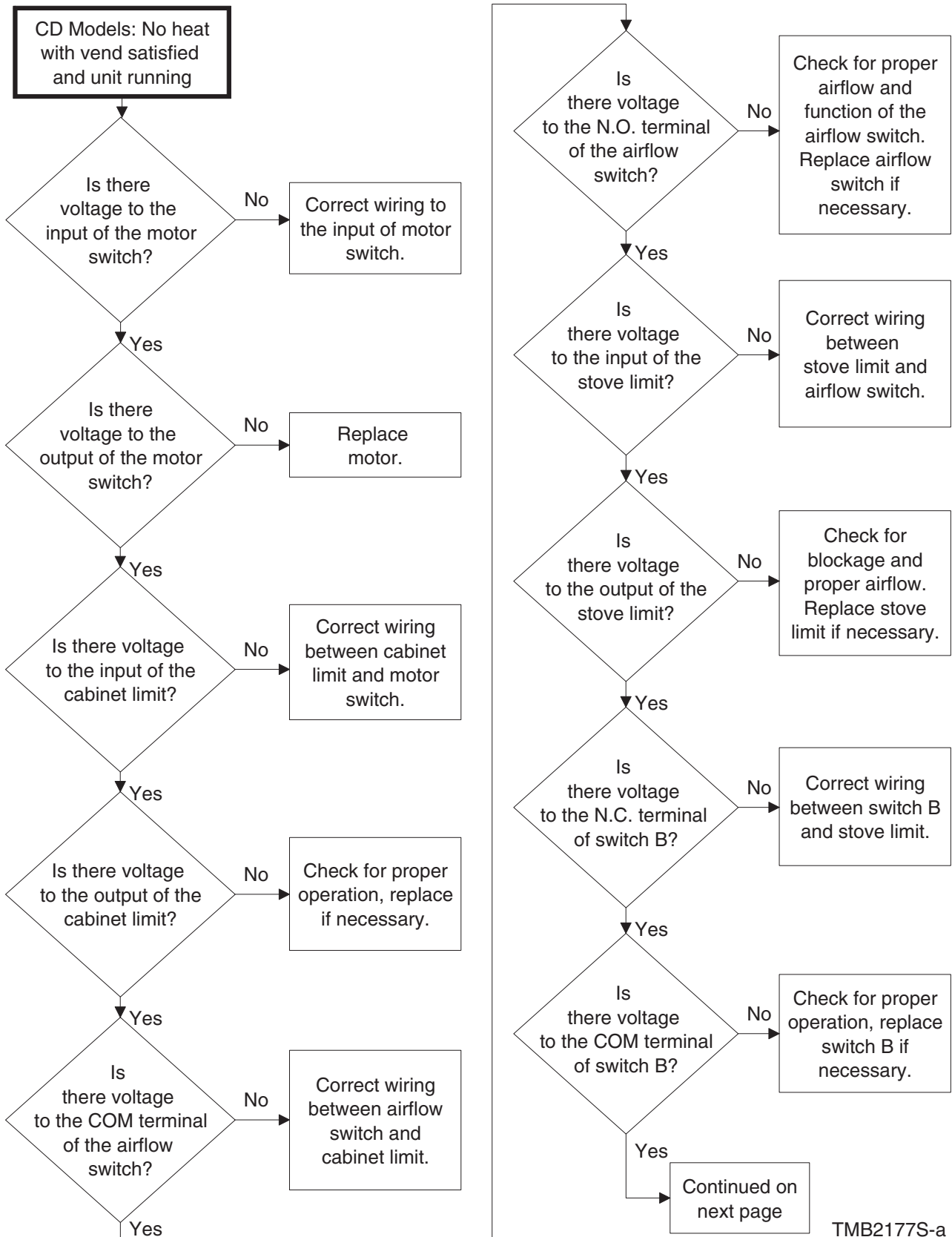

TMB2177S-a

50. CD Models: No Heat With Vend Satisfied and Unit Running (continued) 208-240 Volt/60 Hertz/3 Phase Gas Nonreversing

NOTE: All voltage checks are referenced to neutral unless stated otherwise.

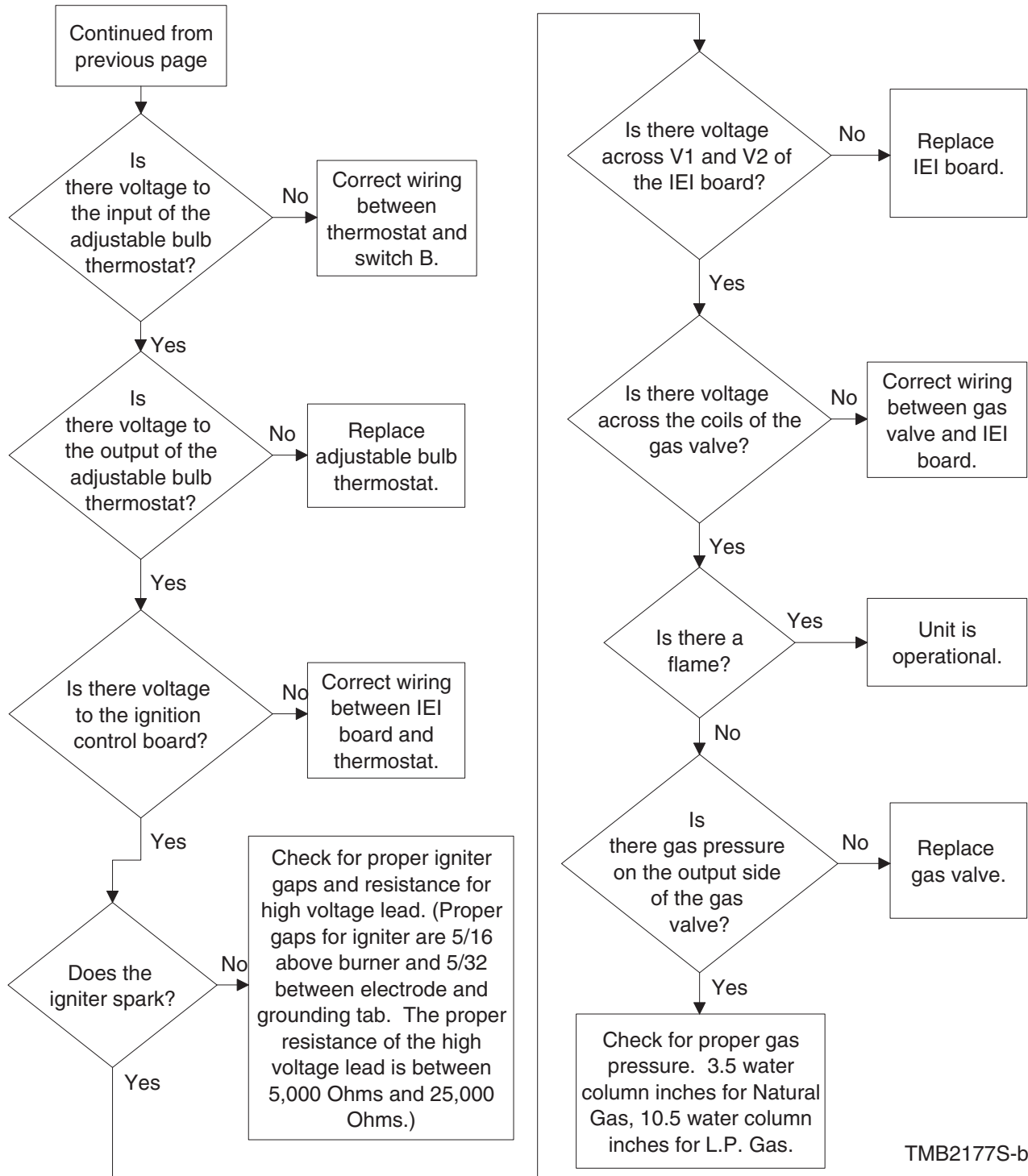

TMB2177S-b

51. CD Models: No Heat With Vend Satisfied and Unit Running 120 Volt/60 Hertz/1 Phase and 240 Volt/60 Hertz/1 Phase Gas Nonreversing Models

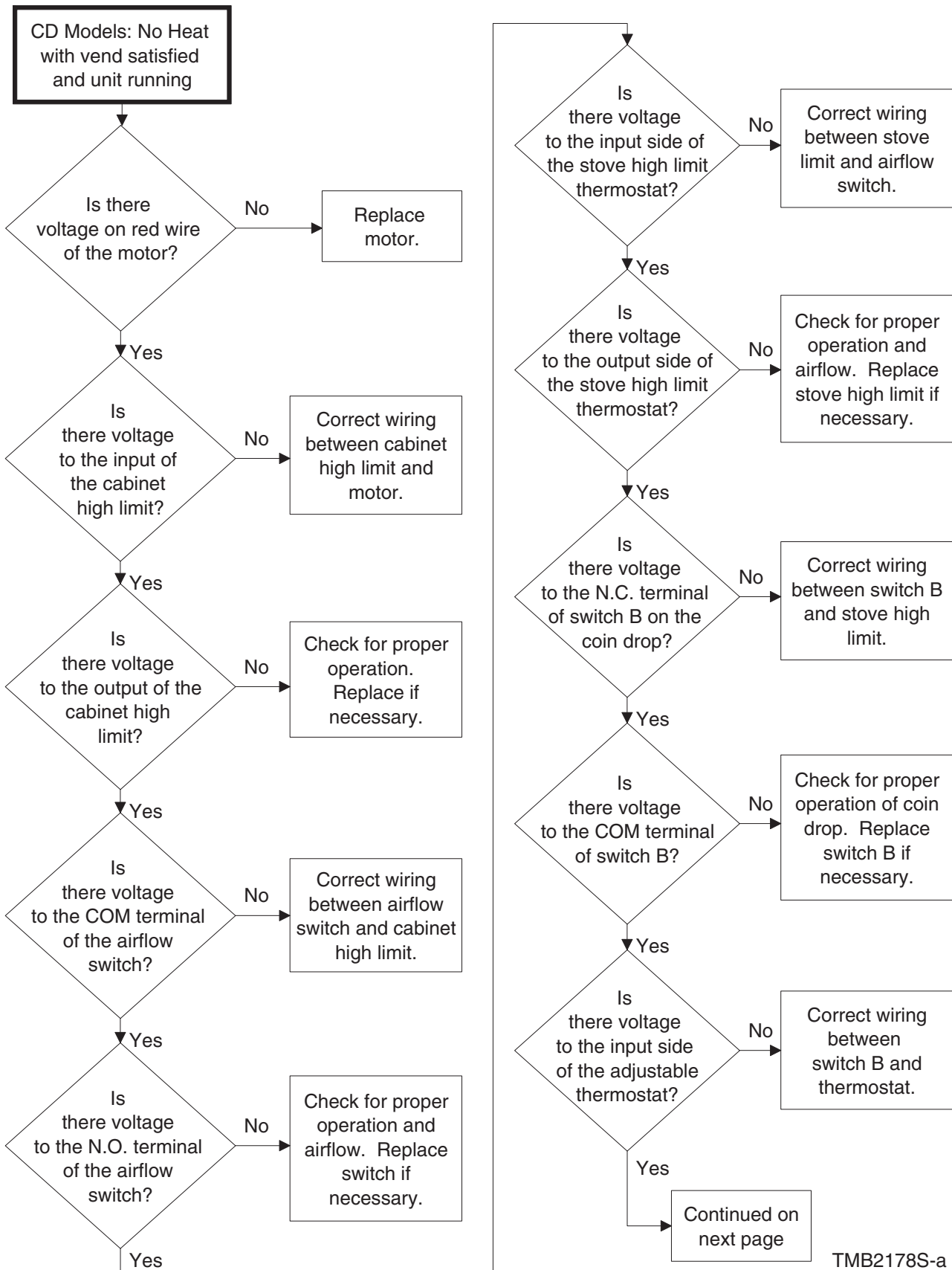

TMB2178S-a

51. CD Models: No Heat With Vend Satisfied and Unit Running (continued) 120 Volt/60 Hertz/1 Phase and 240 Volt/60 Hertz/1 Phase Gas Nonreversing Models

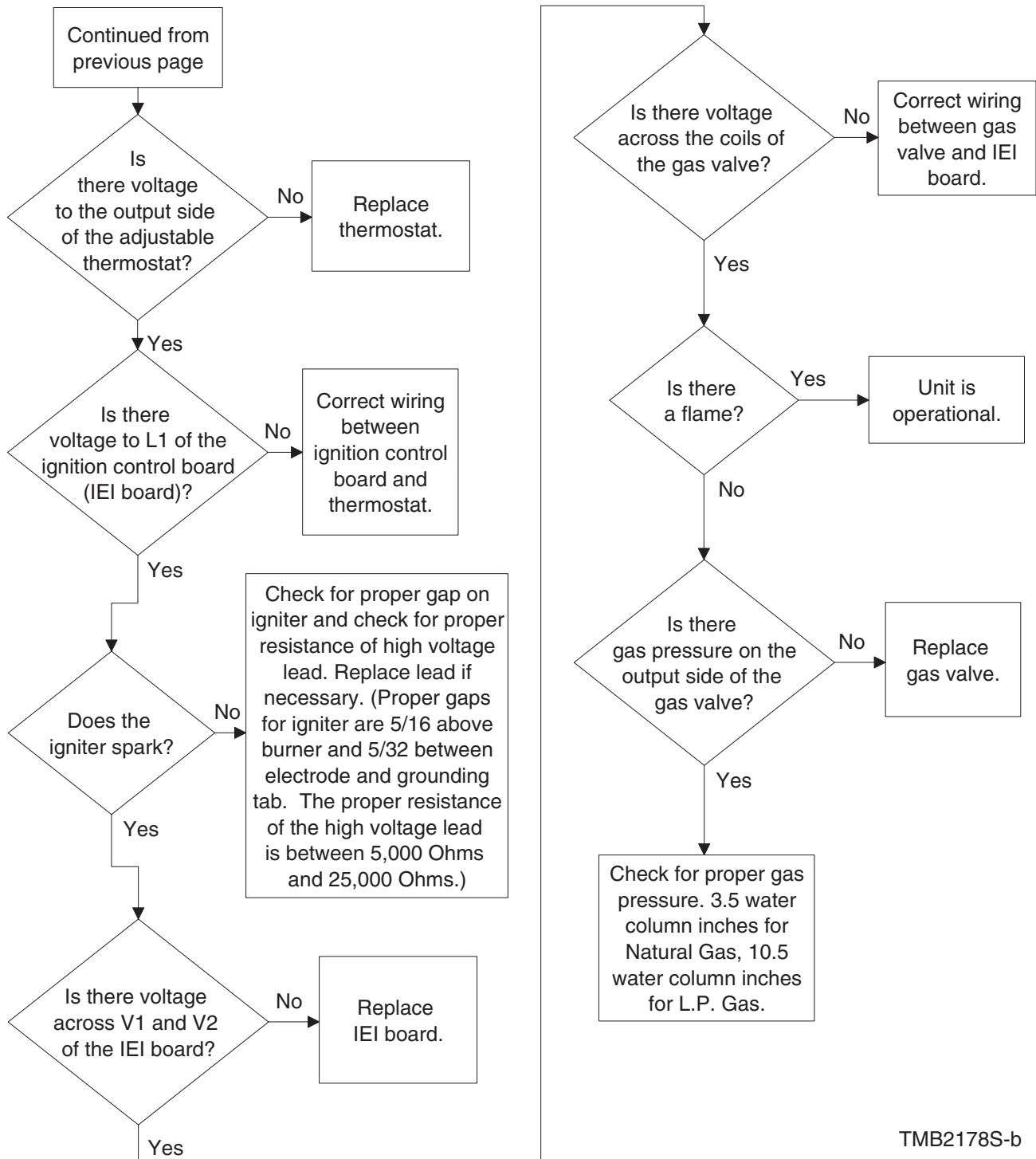

TMB2178S-b

52. CD Models: No Start With Vend Satisfied and Start Button Pushed 240 Volt/60 Hertz/1 Phase Gas Nonreversing

NOTE: All voltage checks are referenced to neutral unless stated otherwise.

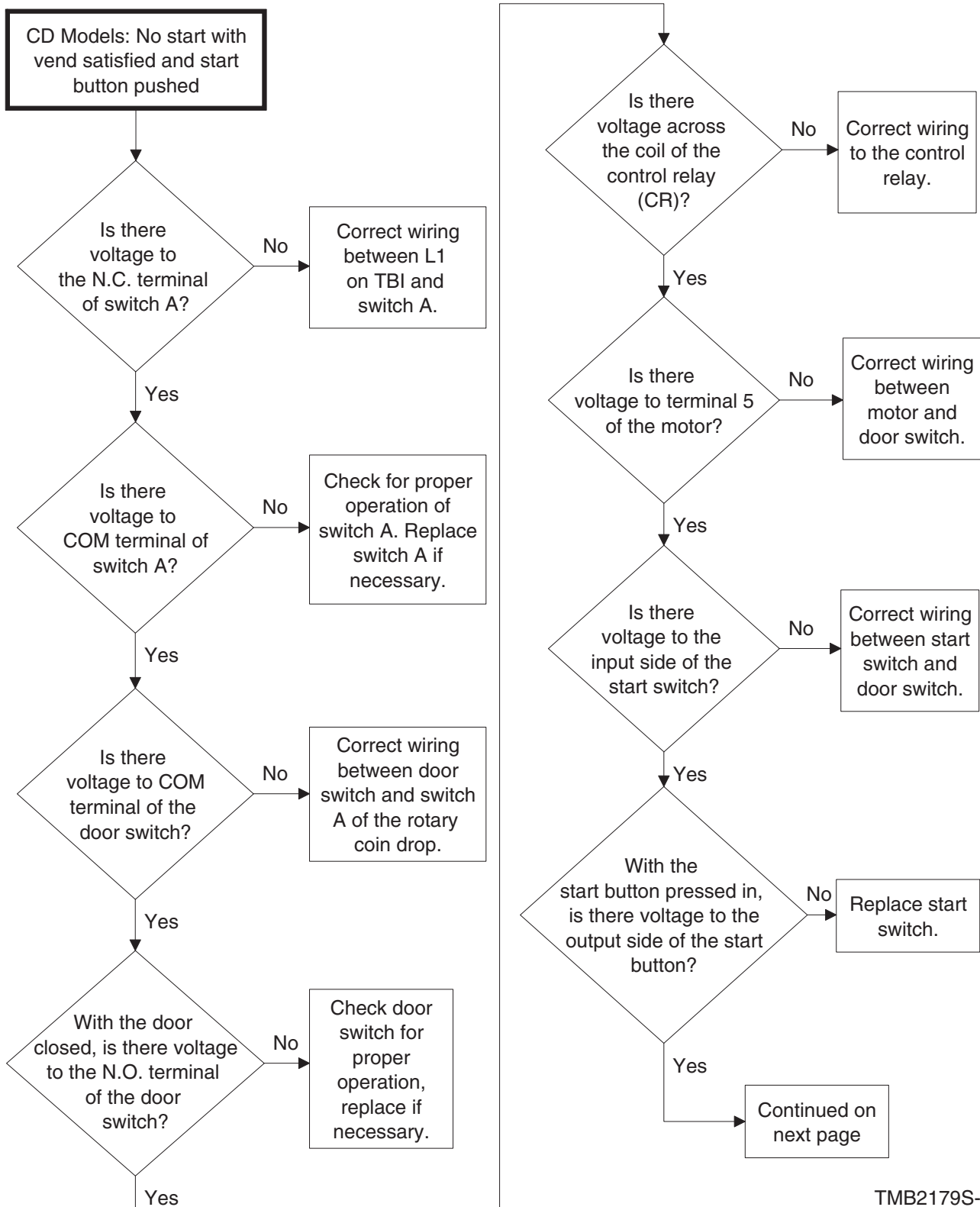

TMB2179S-a

NOTE: If motor only runs with start switch pressed in, that means centrifugal switch in motor is bad. Replace motor.

52. CD Models: No Start With Vend Satisfied and Start Button Pushed (continued)

240 Volt/60 Hertz/1 Phase Gas Nonreversing

NOTE: All voltage checks are referenced to neutral unless stated otherwise.

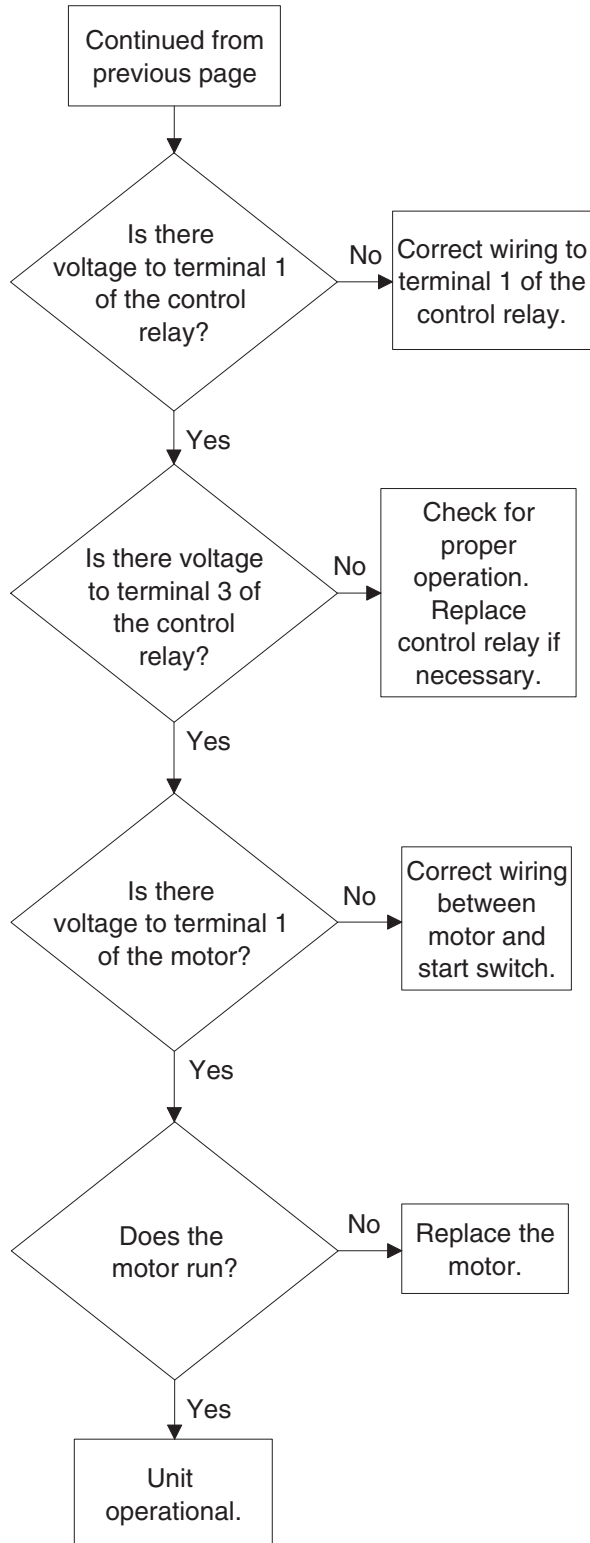

TMB2179S-b

NOTE: If motor only runs with start switch pressed in, that means centrifugal switch in motor is bad. Replace motor.

53. CD Models: No Start With Vend Satisfied and Start Button Pushed 120 Volt/60 Hertz/1 Phase Gas Nonreversing

NOTE: All voltage checks are referenced to neutral unless stated otherwise.

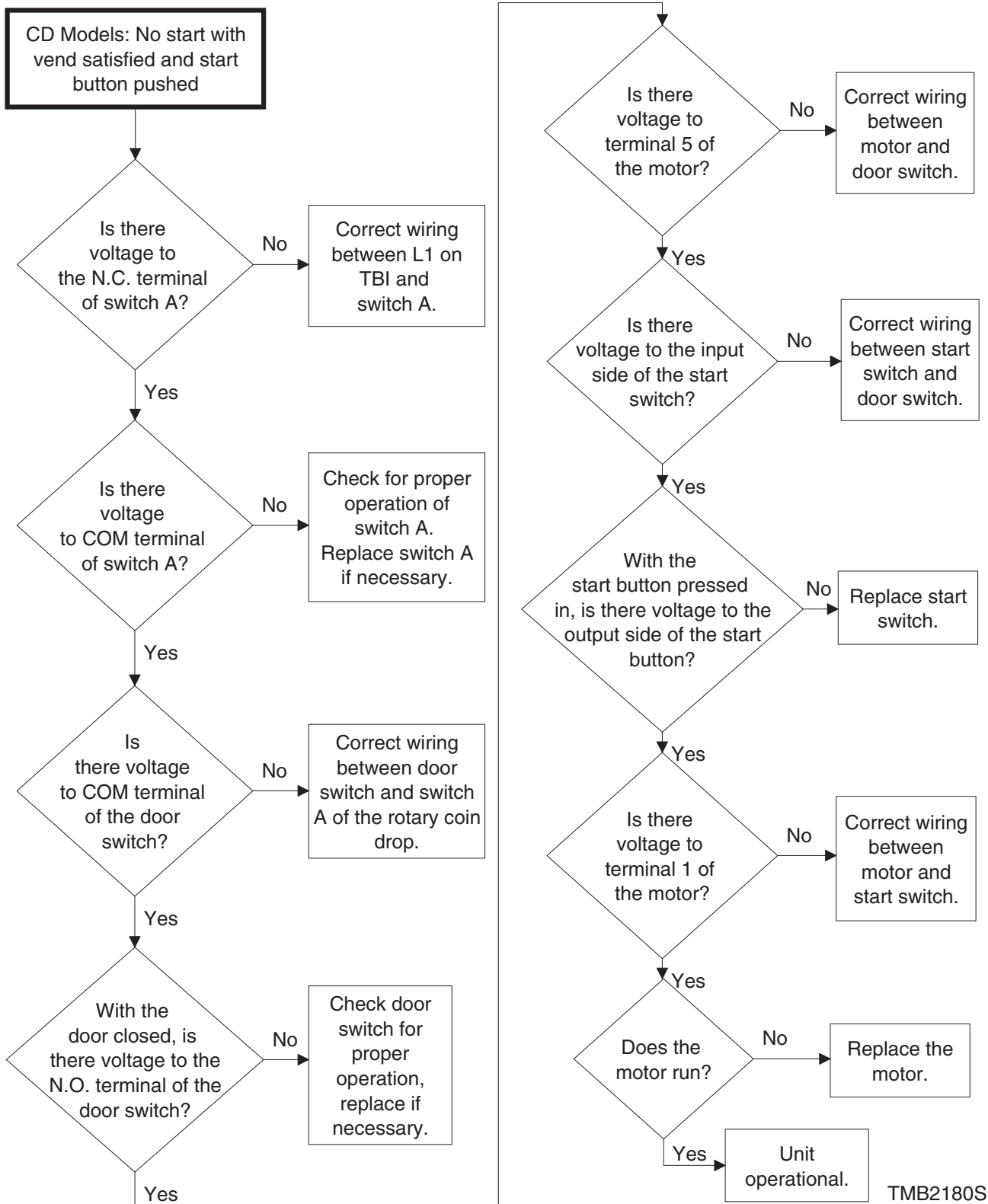

TMB2180S

NOTE: If motor only runs with start switch pressed in, that means centrifugal switch in motor is bad. Replace motor.

Section 4 Adjustments



WARNING

To reduce the risk of electric shock, fire, explosion, serious injury or death:

- Disconnect electric power to the tumbler before servicing.
- Close gas shut-off valve to gas tumbler before servicing.
- Close steam valve to steam tumbler before servicing.
- Never start the tumbler with any guards/panels removed.
- Whenever ground wires are removed during servicing, these ground wires must be reconnected to ensure that the tumbler is properly grounded.

W002

54. Cylinder Clearance

The clearance between the cylinder rim and front panel must be adjusted so the cylinder is centered within the front panel opening when the cylinder is fully loaded and is turning. However, the adjustment should be made when the cylinder is empty.

NOTE: If the cylinder is not properly adjusted, the cylinder rim will rub against the front panel.

- a. Open loading door and check the gap between the center of the front panel top flange and the cylinder rim. Proper adjustment is when the gap is 7/16 inch (11 mm). Refer to *Figure 1*.
- b. Remove chain guard.
- c. Loosen the four trunnion housing bolts. Refer to *Figure 2*.
- d. Loosen the locknuts on the trunnion housing adjusting bolts. Refer to *Figure 2*.

- e. Turn the adjusting bolts in or out as necessary to obtain proper clearance between cylinder rim and front panel.

NOTE: Turning the adjusting bolts clockwise will raise the cylinder and turning them counter-clockwise will lower the cylinder. Turn both bolts evenly to adjust top and bottom clearance. Turn one or the other adjusting bolt in or out to adjust side clearance.

- f. After the cylinder is properly adjusted, tighten the adjusting bolt locknuts and the four trunnion housing bolts.
- g. Install the chain guard removed in step “b”.

NOTE: If adjusting the trunnion housing fails to correct the clearance, the problem is probably due to a worn trunnion shaft or defective bearings.

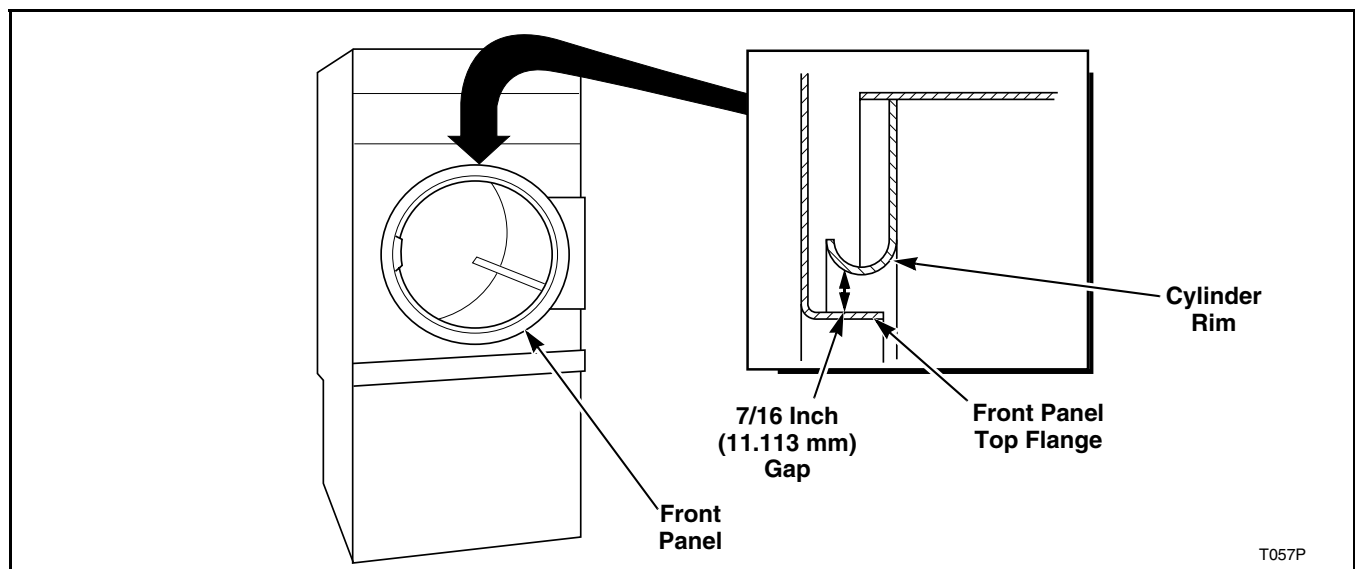

Figure 1

T057P

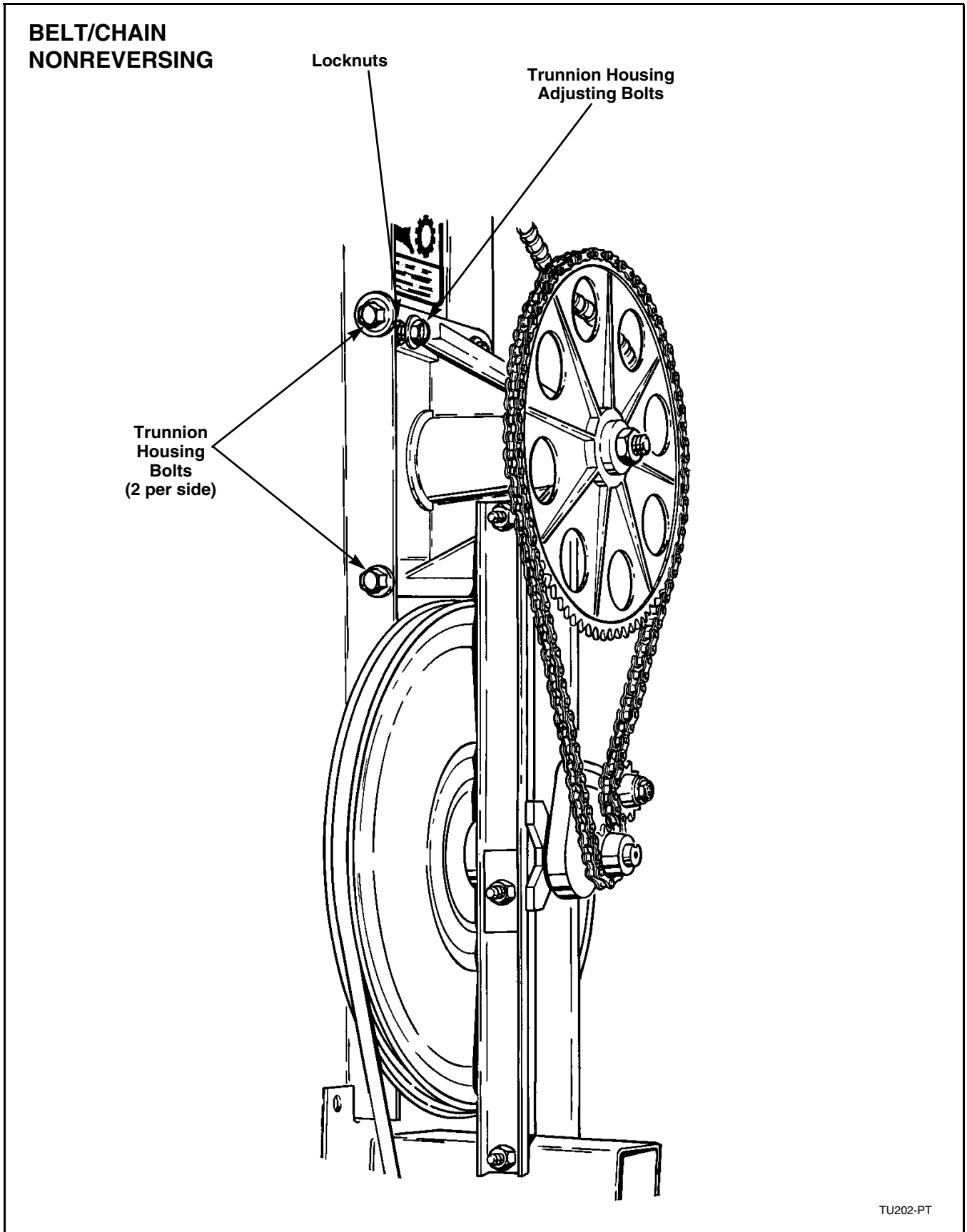

Figure 2